 System / 36

Using the Object Distribution Facility PRPQ

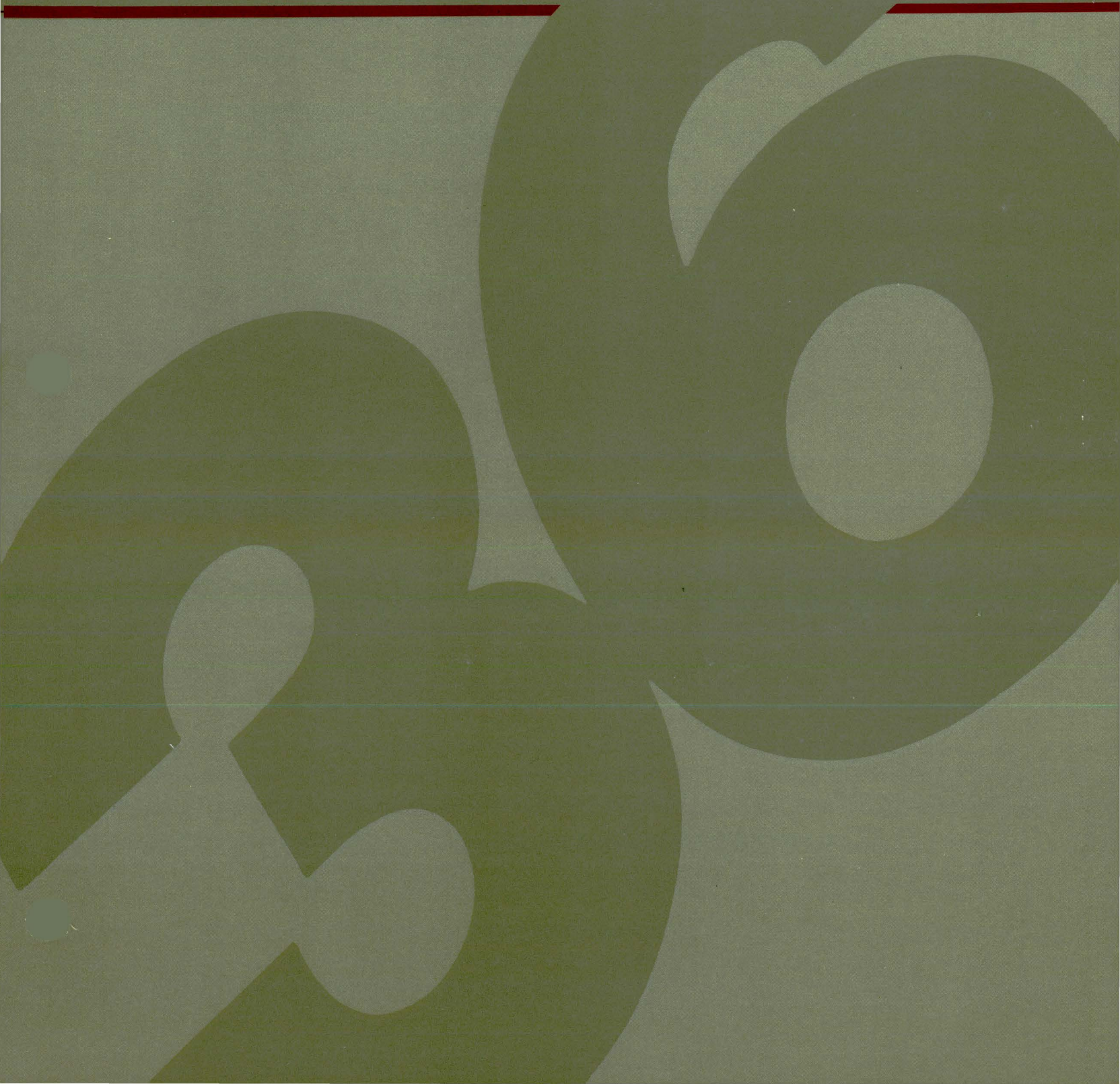

IBM System/36 Object Distribution Facility PRPQ (P84154) for the 5363, 5364, and 5365 (Japan only) System Units Program Number 5799-CXG

The IBM System/36 Object Distribution Facility PRPQ provides the capability to distribute objects between systems in an SNA distribution services (SNADS) network over synchronous data link control (SDLC), IBM Token-Ring Network, or X.25 communications. Object types include library members, files, spooled print files, program temporary fixes (PTFs), folders, job streams, and messages.

Using the Object Distribution Facility PRPQ, objects can be sent to or received from other AS/400¹ systems, System/36s, or System/38s.

The Object Distribution Facility PRPQ can exchange objects with VM/370 in a BSC RSCS network; in effect, a System/36 becomes a VM node. The Object Distribution Facility PRPQ, when used in conjunction with the VM Line Driver PRPQ (5799-DAE), is a gateway from System/36 networking to VM/RSCS and to System/370 networking, including MVS as well as other VM systems. System/38 Object Distribution can use a System/36 with the Object Distribution Facility PRPQ as a gateway to System/370 networking. Print files exchanged with RSCS are limited to 132 or fewer characters.

DISOSS on an MVS/370 system can be used as an intermediate node for routing objects to and from the Object Distribution Facility PRPQ. Also, the Object Distribution Facility PRPQ can be used as an intermediate node for routing Personal Services/36 and DSX generated objects.

The messaging facility in the Object Distribution Facility PRPQ can also be used to exchange messages with an IBM Personal Computer or Personal System/2¹ attached to a System/36 by the IBM Token-Ring Network.

Objects can be stored on any supported system types. Depending on system type, not all objects can be used. For example, a System/38 save file cannot be used on a System/36. However, a System/38 save file can be stored

on a System/36 and subsequently sent to and restored on a System/38.

With the Object Distribution Facility PRPQ, interactive and batch commands are provided to access objects that are to be sent or have arrived for a user. Typical uses of this PRPQ are to distribute files and programs from a central site to remote locations, and to route print spool files from one system to another for printing. With the Object Distribution Facility PRPQ, a user can, after signing on system A and passing through to system B, run a job on system B and print the output from that job on system A. Text-only printing is supported (no graphics or image). Automatic support of printer pass-through requires writing simple OCL procedures. The Object Distribution Facility PRPQ can also be used for archiving files on an alternate system.

The Object Distribution Facility PRPQ can send objects to an individual or a list of users. Capabilities are provided for defining and maintaining the distribution lists required for object distribution over a network. The total number of recipients for one transmission cannot exceed 150. SNADS is used for network and system distribution support, the same support used by Personal Services/36 (Personal Services/36 is not a prerequisite for the Object Distribution Facility PRPQ).

Specified Operating Environment

Machine Requirements

The IBM System/36 Object Distribution Facility PRPQ is designed to run on all models of the System/36. An available communications line configured for the appropriate protocol is required.

¹ Trademarks of International Business Machines Corporation.

Programming Requirements

The IBM System/36 Object Distribution Facility PRPQ requires IBM System/36 System Support Program Product (5727-SS6) Release 5, Modification Level 1, or later compatible releases. The Base Communications feature is also required.

The System/3X VM Line Driver PRPQ (5799-DAE) for the VM RSCS link is optional.

Warranty

The IBM System/36 Object Distribution Facility PRPQ (5799-CXG) is warranted to conform to its Licensed Program Specifications when shipped to the customer if properly used in the Specified Operating Environment.

Licensed Program Specifications may be updated from time to time and such updates may constitute a change in specifications.

Following the discontinuance of all program services, this program will be distributed on an "As Is" basis without warranty of any kind either express or implied.

Any other documentation with respect to this licensed program, including any documentation referenced herein, is provided for information purposes only and does not extend or modify these specifications.

International Business Machines Corporation
Department 245
Highway 52 and Northwest 37th Street
Rochester, Minnesota, U.S.A. 55901

June 1988 Printed in U.S.A. GC21-9812-0

GC21-9812-00



**IBM System/36:
Using the
Object Distribution Facility
PRPQ**

Document Number SC21-9800-0

First Edition (June 1988)

This edition applies to Release 1, Modification Level 0, of the IBM System/36 Object Distribution Facility PRPQ 5799-CXG for the 5360, 5362, and PRPQ 5799-CXG for the 5363, 5364 System Unit and to all subsequent releases and modifications until otherwise indicated in new editions or Technical Newsletters.

Changes are periodically made to the information herein; any such changes will be reported in subsequent revisions or Technical Newsletters.

This publication contains examples of data and reports used in daily business operations. To illustrate them as completely as possible, the examples include the names of individuals, companies, brands, and products. All of these names are fictitious and any similarity to the names and addresses used for an actual business enterprise is entirely coincidental.

References in this publication to IBM products, programs or services do not imply that IBM intends to make these available in all countries in which IBM operates. Any reference to an IBM licensed program in this publication is not intended to imply that only IBM's licensed program may be used. Any functionally equivalent program may be used instead.

The numbers at the bottom right of illustrations are publishing control numbers and are not part of the technical content of this manual.

Publications are not stocked at the address given below. Requests for IBM publications should be made to your IBM representative or to your IBM-approved remarketer.

This publication could contain technical inaccuracies or typographical errors. A form for readers comments is provided at the back of this publication. If the form has been removed, comments may be addressed to IBM Corporation, Information Development, Department 245, Rochester, Minnesota, U.S.A. 55901. IBM may use or distribute whatever information you may supply in any way it believes appropriate without incurring any obligation to you.

AS/400 is a trademark of the International Business Machines Corporation.

About This Manual

This manual may refer to products that are announced, but are not yet available.

Who Should Use This Manual

This manual is written for persons using Object Distribution Facility/36 to electronically distribute data in a network of systems.

What You Should Know

Before you use this manual you must be familiar with the introductory material for using the IBM System/36. You do not have to understand how to use a high-level programming language to use Object Distribution Facility/36.

How This Manual Is Organized

This manual is organized as follows:

- Chapter 1 introduces Object Distribution Facility/36 and the communications support it uses.
- Chapter 2 describes how to plan for and set up Object Distribution Facility/36 on your system.
- Chapter 3 describes the menu and procedure interfaces for running Object Distribution Facility/36.
- Chapters 4, 5, 6, and 7 are intended for the system administrator.

Information on how Object Distribution Facility/36 can be used to automate common network functions, and assist in unattended environments, is provided in Chapter 4.

Information on the differences between the systems supported by Object Distribution Facility/36 is provided in Chapter 5.

Information on using the "log" functions in Object Distribution Facility/36 to help solve problems is provided in Chapter 6.

Information on how system performance may be improved is provided in Chapter 7.

- Appendixes.

The appendixes include information on the ODF/36 utility programs, the examples given in this manual, and error messages.

This manual also contains a glossary and an index.

Related Online Information

The following online information is available.

Help for Displays

You can press the Help key on any ODF/36 display to see information about the display. There are two types of help available.

General

Specific

General help explains the purpose of the display. General help appears if you press the Help key when the cursor is outside the areas for which specific help is available.

Specific help is the field on which the cursor is positioned when you press the Help key. For example, it describes the choices available for a prompt.

Online Information

Help for Personal Services/36 (SNADS) is in a document folder called #OFCFLDR. The information in this folder can be viewed by pressing the Help key on any Personal Services/36 (SNADS) display, as described for ODF/36 above, and can also be selectively viewed or printed by using the READINFO procedure. It is recommended that the Personal Services/36 (SNADS) online information is printed for use as a reference manual. See the *System Reference* for information on the READINFO procedure.

Related Printed Information

If you need more information, refer to the following manuals:

System/36 Manuals

- *Administering Personal Services in the Office*, SC09-1062
- *Advanced Peer-to-Peer Networking Guide*, SC21-9471
- *Interactive Communications Feature: Base Subsystems Reference*, SC21-9530
- *Interactive Communications Feature: Guide and Examples*, SC21-7911
- *Using System/36 Communications*, SC21-9082
- *Operating Your Computer 5360, 5362*, SC21-9452
- *Operating Your Computer 5364*, SC21-9453
- *System Messages*, SC21-7938
- *System Reference*, SC21-9020
- *System Security Guide*, SC21-9041

AS/400 Manuals

- *Communications: Advanced Program-to-Program Communications and Advanced Peer-to-Peer Networking User's Guide*, SC21-9598
- *Communications: Distribution Services Network Administrator's Guide*, SC21-9588
- *Communications: Programmer's Guide*, SC21-9590
- *PC Support: Installation Guide*, SC21-8089
- *Programming: Command Reference Summary*, SC21-8076
- *Programming: Control Language Programmer's Guide*, SC21-8077
- *Programming: Control Language Reference*, SBOF-0481
- *Programming: System Reference for the System/36 Environment*, SC21-9662
- *Programming: System Reference Summary*, SC21-8104
- *System Operations: Operator's Guide*, SC21-8082
- *System/36-to-AS/400 Migration Aid User's Guide and Reference*, SC09-1166

System/38 Manuals

- *System/38 Control Language Reference*, SC21-7731
- *System/38 Control Program Facility Programmer's Guide*, SC21-7730
- *System/38 Communications Administrator's Guide*, SC21-8035

S/370 Manuals

- *CMS Command and Macro Reference*, SC19-6209
- *Remote Spooling Communications Subsystem Network Programming Reference and Operations Manual*, SH24-5005

Communications Protocols

- *SNA Format and Protocol Reference Distribution Services*, SC30-3098 (SNADS)

Contents

Chapter 1. Introduction	1-1
Object Distribution Facility/36 and SNADS	1-3
The Directory	1-4
Lists	1-4
Introducing Personal Services/36 (SNADS)	1-4
Setting Up Your System for Object Distribution	1-8
General Information on Sending Objects	1-9
RSCS Parameters	1-10
Requesting an acknowledgment	1-10
Chapter 2. Setting Up ODF/36	2-1
software installation	2-1
VM/RSCS Software Installation	2-1
System/36 Software Installation	2-2
Installing Object Distribution Facility/36	2-3
Removing Object Distribution Facility/36	2-5
Software Configuration	2-5
Initializing Object Distribution Facility/36	2-5
Initializing Personal Services/36 (SNADS)	2-13
Defining Communications Routes and Queues	2-26
Setting Up Communications Routes	2-27
Setting Up Communications Queue Definitions	2-36
Defining Remote Directory Entries	2-47
Setting Up Directory Entries	2-47
Chapter 3. Running ODF/36	3-1
Sending Objects Interactively	3-2
ODF/36 Procedures	3-10
LISTOBJ Procedure	3-12
LISTRSCS procedure	3-30
MSG Control Command	3-36
ODF Procedure	3-39
ODFCANCL Procedure	3-39
ODFDFLT Procedure	3-40
ODFINSTL Procedure	3-40
ODFIPL Procedure	3-41
ODFLOAD Procedure	3-42
ODFPROF Procedure	3-43
ODFSTART Procedure	3-46
OFCCANCL Procedure	3-46
OFCCOMM Procedure	3-47
OFCCTRL Procedure	3-48
OFCDFLT Procedure	3-49
OFCDIR Procedure	3-50
OFCGRP Procedure	3-51
OFCINSTL Procedure	3-51
OFCMAINT Procedure	3-52
OFCQ Procedure	3-53
RECVFILE Procedure	3-55
RECVFLDR Procedure	3-56
RECVLIBR Procedure	3-57
RECVPRT Procedure	3-58

SENDFILE Procedure	3-59
SENDFLDR Procedure	3-63
SENDJOB Procedure	3-65
SENDLIBR Procedure	3-67
SENDPRT Procedure	3-70
STOPRSCS Procedure	3-73
STRTRSCS Procedure	3-74
Chapter 4. Automated and Unattended Operations	4-1
Processing Job Streams	4-3
Sending Jobs from a Central Site System	4-4
Processing Spooled Print Files	4-6
Printing with LISTOBJ	4-6
Automatic Printing	4-6
Printing with RECVPRT	4-6
Arrived Objects Procedure	4-8
Central Development - Local Edit, Remote Compile	4-13
Program Temporary Fix (PTF) Distribution	4-15
Distribute PTF Libraries	4-15
Distribute Members with a PTF Applied	4-15
Printer Passthru	4-17
Managing Communications in Batch	4-20
Chapter 5. Cross-System Considerations	5-1
System/38	5-2
Object Naming Differences	5-2
General Object Differences	5-2
Archiving System/36 Objects on System/38	5-3
Archiving System/38 Objects on System/36	5-3
VM/370	5-3
Object Naming Differences	5-3
General Object Differences	5-4
Archiving System/36 Objects on VM/370	5-5
AS/400 System	5-6
Object Naming Differences	5-6
General Object Differences	5-7
Archiving System/36 Objects on the AS/400 System	5-7
Archiving AS/400 Objects on System/36	5-7
Exchanging Objects with the AS/400 System/36 Environment	5-7
Chapter 6. Problem Determination	6-1
Distribution Log File Manager	6-2
Programs that Create Log File Entries	6-4
Considerations for Processing the Distribution Log File	6-6
Chapter 7. Improving System Performance	7-1
Sizing the ODF Folder	7-2
General Information on Folders	7-2
ODF Folder Design	7-2
Creating the ODF Folder	7-4
How Extents Affect the Task Work Area	7-6
Sending Objects in S36FMT or DATA	7-6
Sending Files in S36FMT or DATA	7-6
Sending Library Members in S36FMT or DATA	7-7
Appendix A. ODF/36 Utility Programs	A-1

\$NTSNO Utility	A-2
Sending Disk Files (SENDFILE Procedure)	A-3
Sending a Folder (SENDFLDR Procedure)	A-4
Sending a Job Stream (SENDJOB Procedure)	A-5
Sending Library Member(s) (SENDLIBR Procedure)	A-6
Sending Spooled Print File(s) (SENDPRT Procedure)	A-7
Appendix B. The EXAMPLES Diskette File	B-1
How to Load the Examples	B-2
Examples Cross-Reference	B-2
Appendix C. Object Distribution Facility/36 Messages	C-1
Appendix D. Personal Services/36 (SNADS) Messages	D-1
Glossary	G-1
Index	X-1

Chapter 1. Introduction

The Object Distribution Facility/36 PRPQ provides a method of sending objects and messages from one S/36 user to another S/36, S/38, AS/400, or S/370 user or list of users¹. Users can send files, library members, folders, job streams, spooled print files and messages.

Any user can use Object Distribution Facility/36 (ODF/36) to send objects. After your system is configured for Object Distribution Facility/36, users can:

- Send files, local or remote.
- Send library members, local or remote.
- Send a folder, local or remote.
- Submit job streams to run on a remote site.
- Send messages to specific users at the local site or at remote sites.
- Send spooled print files to a remote site for processing.

Object Distribution Facility/36 also allows you to:

- Keep remote sites primarily unattended.
- Send either object or source code.
- Maintain a compiler at the remote site (optional).
- Send objects to an individual user or a list of users.
- Send messages to an IBM Personal Computer or Personal System/2 attached by the IBM Token-Ring network.

The following list describes the principal functions and commands that can be used in Object Distribution Facility/36 to send and receive objects and messages:

- Send a File (SENDFILE) procedure sends a file or file group to another user.
- Send Library Members (SENDLIBR) procedure sends a library member or library members to another user.
- Send a Folder (SENDFLDR) procedure sends a folder to another user.
- Send a Message (MSG) command sends a message to another user. The user may also be an IBM Personal Computer or Personal System/2 attached by the IBM Token-Ring network running the PC/Support Message Facility. Messages are sent high priority.
- Send a Spooled Print File (SENDPRT) procedure sends spooled print file(s) to another user. The spooled print file is placed in the user's list of arrived objects, or is automatically printed according to the user's object distribution profile or the system object distribution profile.
- Send a Job Stream (SENDJOB) procedure sends a job stream to another user on the network. The job stream is placed in the user's list of arrived objects, or is

¹ AS/400 is a trademark of the International Business Machines Corporation.

automatically submitted according to the user's object distribution profile or the system object distribution profile.

- Work with Arrived Objects (LISTOBJ) procedure displays a list of all objects that have arrived for a S/36 user. Objects can be received, deleted, viewed, or printed.
- Receive into File (RECVFILE) procedure receives an object by copying the data into a file.
- Receive into Folder (RECVFLDR) procedure receives a folder object by copying the data into a folder.
- Receive into Library (RECVLIBR) procedure receives an object by copying the data into a library.
- Receive Spooled Print File (RECVPRT) procedure receives a spooled print file object by copying the data to the spool file.
- Work with ODF/36 profiles (ODFPROF) procedure allows a S/36 user to create, update, or delete their ODF/36 profile. A user with security officer authority, or higher, may work with any users ODF/36 profile.

For additional information on these procedures, see Chapter 3, "Running ODF/36."

Object Distribution Facility/36 and SNADS

Figure 1-1 shows the relationship of ODF/36 on the system.

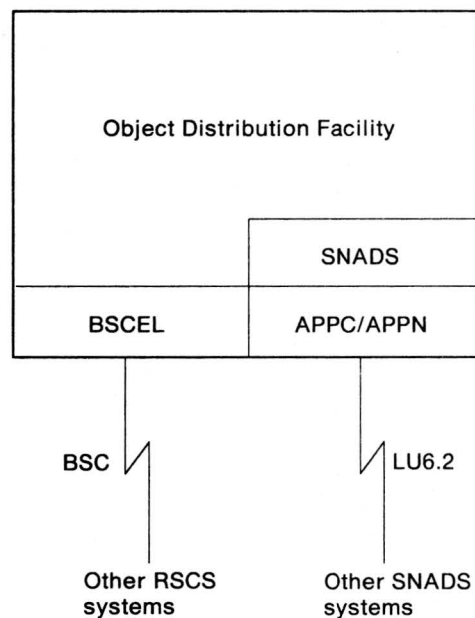

R36L039-0

Figure 1-1. The Relationship of ODF/36 on the System. Object Distribution Facility/36 is a SNADS application. That is, it uses the routing, queueing, directory, list, and transmission functions of SNADS to distribute objects in a SNADS network. Object Distribution Facility/36 also uses the routing, directory, and list functions of SNADS to distribute objects in an RSCS network. However, Object Distribution Facility/36 provides the queueing and transmission functions for RSCS independently of SNADS. RSCS transmission functions are accomplished using a subset of binary synchronous communications equivalence link (BSCEL) support.

Systems network architecture distribution services (SNADS) is a distribution service that can distribute data, such as: objects, messages, and status information to other systems that are directly or indirectly attached to your system. A SNADS configuration must exist on all systems that use the distribution services.

The link to other systems in the network is determined and controlled by several items in the SNADS application:

- The **communications queues** manage the sending of different priorities of objects between systems.
- The **communications routes** define the path for a distribution to reach its destination.
- The **remote destinations** allow objects to be sent to remote locations without specifying each remote user at your system.

On System/36, SNADS is implemented in the Personal Services/36 product. However, it is not required to have Personal Services/36 installed to use Object Distribution Facility/36. The functions required for Object Distribution Facility/36 to participate in a SNADS network are provided with the Object Distribution Facility/36 PRPQ. These functions, plus the directory and list functions required to

use SNADS, constitute a subset of the Personal Services/36 product. Throughout this manual, the term **Personal Services/36 (SNADS)** is used to represent SNADS on the System/36, that is, the SNADS portion of Personal Services/36 provided with Object Distribution Facility/36.

Personal Services/36 (SNADS) allows only IBM-provided applications, for example, Object Distribution Facility/36 or DSNX Network Distribution, to use its functions to send and receive distributions.

In addition to the communications functions, the following Personal Services/36 (SNADS) functions are provided.

The Directory

In your office, you may have name, address, and telephone number lists. You can replace them with the Personal Services/36 (SNADS) directory. The Personal Services/36 (SNADS) directory contains names, addresses, telephone numbers, user IDs, and other information about users of Personal Services/36 (SNADS) on your system. It can also contain entries for users on other systems connected to yours. The directory may also contain information about people or companies you do business with that do not use Personal Services/36 (SNADS). To use Personal Services/36 (SNADS) you must be added to the directory.

Lists

The list processing function helps you use the other parts of Personal Services/36 (SNADS) more effectively. If you often send objects to the same people, you can put their user IDs in a list and give the list a name. When you send an object to these people, you can send it using the list name, not each individual user ID.

Introducing Personal Services/36 (SNADS)

Personal Services/36 (SNADS) uses routes, queues, and the directory to sort, send, and receive objects. This section contains information to help you set up your system.

Figure 1-2 on page 1-5 shows how objects are sent by Personal Services/36 (SNADS) to remote systems. When Personal Services/36 (SNADS) sends or receives objects between systems, it uses data communication facilities such as modems, telephone lines, the System/36 advanced program-to-program communications program (APPC) subsystem, or the advanced peer-to-peer networking (APPN) subsystem. These form a transport system like the trucks or trains used to carry objects in conventional mail systems.

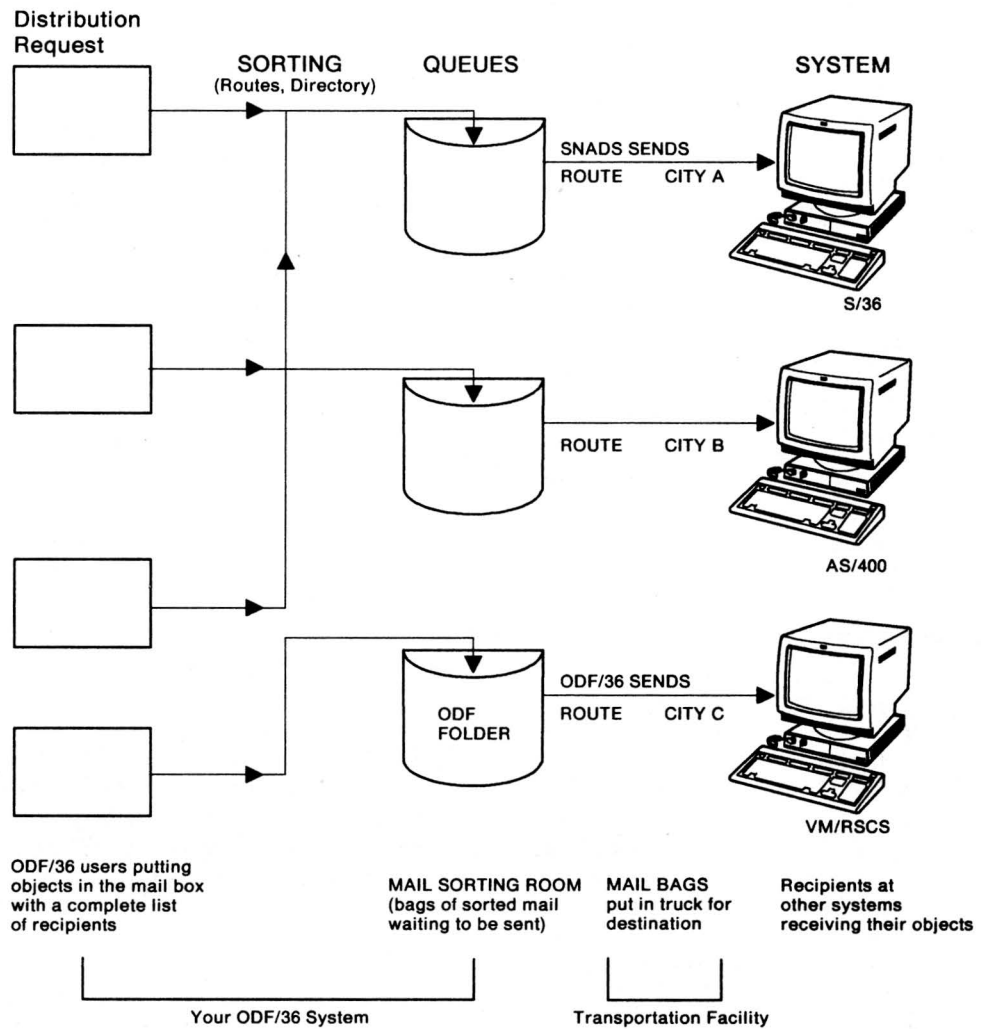

Figure 1-2. Personal Services/36 (SNADS) Sending Objects to Remote Systems

Remote distribution to VM systems and associated networks use the remote spooling communications system (RSCS). Personal Services/36 (SNADS) passes objects for RSCS systems to Object Distribution Facility/36 for processing. Object Distribution Facility/36 (independently of Personal Services/36 SNADS) manages the queues of objects for RSCS systems and the sending and receiving of objects with RSCS systems.

Note: The destination node and route is transparent to the user.

Distribution Request

When you send an object to another system, you specify a user ID, an address, and a priority. This is like putting an address on mail and indicating the delivery class, such as air mail, or surface mail.

Personal Services/36 (SNADS) Sorts

Personal Services/36 (SNADS) gets the request to distribute objects and sorts them into queues. A queue is like a bag of mail. Here, Personal Services/36 (SNADS) acts like a sorting room.

- Personal Services/36 (SNADS) looks up the user ID and address in the directory and finds out to which system the objects are going. The system name is used to identify the route the objects should take. This is like sorting the mail by city.
- The objects are identified for that system, and the objects go in a queue, dependent on the priority and the route. Personal Services/36 (SNADS) looks up the route to that system, and finds the queue that priority goes to. This is like sorting into airmail and surface mail.

Note: If you are communicating with RSCS, there is only one queue. The object is placed in the ODF/36 folder and is sent by Object Distribution Facility/36.

- The objects then wait in queues to be sent. This is like bags of mail waiting to be sent to a city.

Personal Services/36 (SNADS) Sends

After the objects have been sorted, Personal Services/36 (SNADS) sends objects from the queue.

- Personal Services/36 (SNADS) checks the queue definitions to see how objects in that queue are sent. It can be sent based on the amount of objects in the queue, or the operator can decide when to send the objects. When objects are sent, Personal Services/36 (SNADS) uses APPC or APPN to send the data across the communications link. All objects on a queue are sent once the queue is started. This is like putting the bag of mail on a truck.

If Personal Services/36 (SNADS) has problems in sending objects, error messages are sent back to your system and logged in the history file.

Figure 1-3 on page 1-7 is an example of how you might set up routes (what mail goes into what bag) and queues (bags of mail in a mail sorting room) to send objects from your system in Melbourne (MELBSYS).

As shown in the figure, the Melbourne system (MELBSYS) has:

- a route to the Sydney system (SYDNSYS) with one queue,
- a route to the Adelaide system (ADELSYS) with three queues,
- and a route to the Perth system (PERTVM) with one queue.

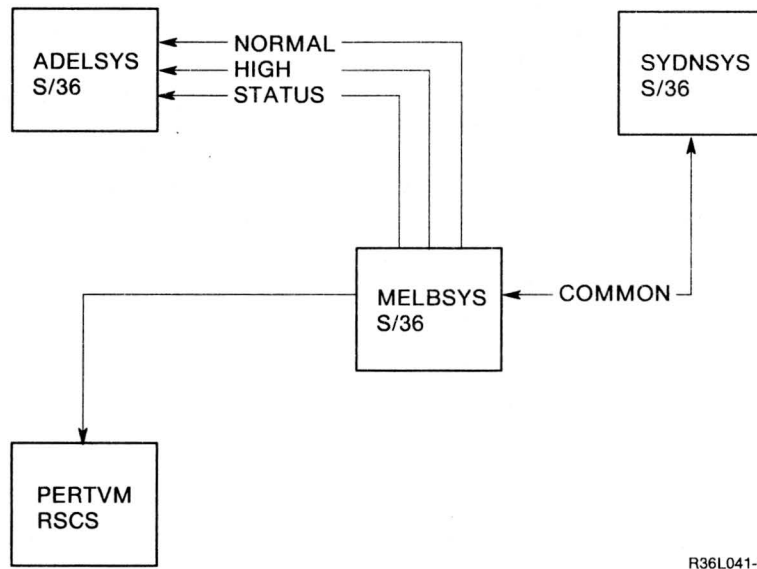

Figure 1-3. An Example of Personal Services/36 (SNADS) Communication Routes and Queues

Note: Notice that in the diagram, PERTVM does not have priorities (status, high, normal).

Personal Services/36 (SNADS) Receives Objects

Figure 1-4 shows how Personal Services/36 (SNADS) receives objects from other systems. Notice there is only one storage folder and one ODF folder per system.

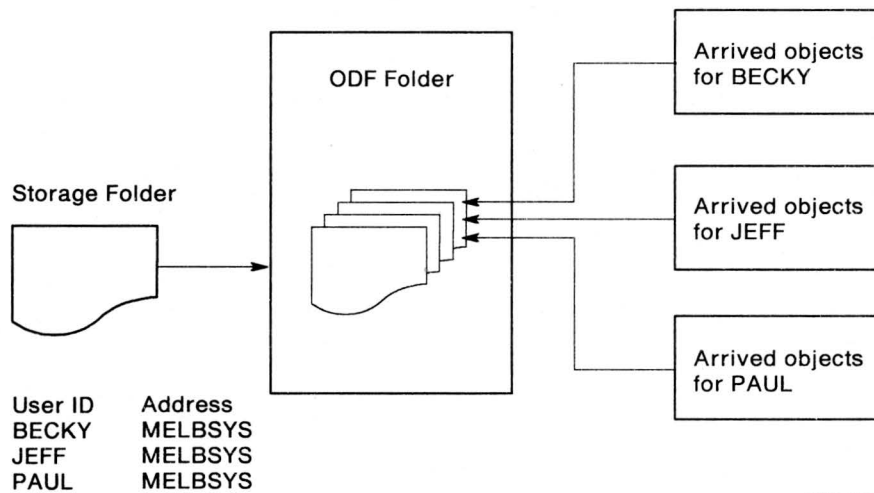

Figure 1-4. How Personal Services/36 (SNADS) Receives Objects

When Object Distribution Facility/36 receives an object requiring acknowledgment of delivery, it sends a message back to the sending user, after the object is placed in the recipient's list of arrived objects. Personal Services/36 (SNADS) can also send status information messages that may indicate problems in sending objects. Personal Services/36 (SNADS) sends these messages the way it sends objects; that is, it decides on which queue to put this information. You can set up and define a special queue for sending these information messages to another system.

When Personal Services/36 (SNADS) receives an object, the object is placed in the **storage folder**. If the object is for a user on this system or for the next RSCS system, then Object Distribution Facility/36 places the object in the ODF folder. The object in the storage folder is deleted, unless it is also to be sent to another SNADS system. Object Distribution Facility/36 thus manages the queues of objects that have arrived for users on this system, and the queues of objects to be sent to the next RSCS system. Object Distribution Facility/36 also manages the sending and receiving of objects with RSCS.

Forwarding Objects to Other Systems

Figure 1-5 shows how the objects flow with the Melbourne system (MELBSYS) as the intermediate point in the network.

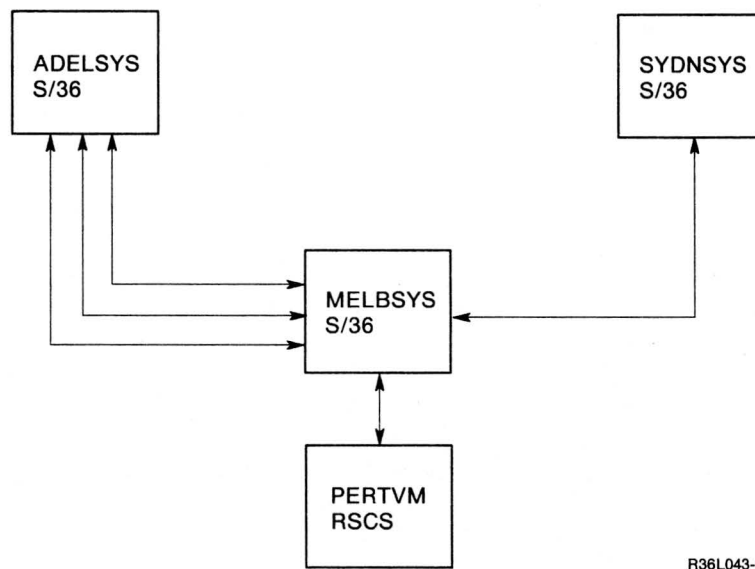

Figure 1-5. Melbourne Forwards Objects to Sydney and to Adelaide

Sometimes your system is a temporary stopping point for objects. In this example, the system in Melbourne is between two other systems. Objects may be sent through your system to other systems. If there are no recipients on this system, the objects are stored in the storage folder on your system until your Personal Services/36 (SNADS) sends them on to the next system. For example, if the system in Adelaide (ADELSYS) sends an object to the system in Sydney (SYDNSYS), the object goes first to the Melbourne system (MELBSYS) and is then forwarded to the Sydney system (SYDNSYS). The object is moved from the ODF folder on ADELSYS to the storage folder on MELBSYS, then to the ODF folder on SYDNSYS.

Setting Up Your System for Object Distribution

Before using object distribution, a user with security officer authority or higher must do the following:

- Configure a distribution network for remote system users. This network defines systems tables used to receive, route, and send distributions in a network of systems. For a complete description, see Chapter 2, "Setting Up ODF/36."
- Enroll all users of object distribution in the directory. This directory is a list of all users known to your system. You can set up distribution lists for groups of

users who frequently receive the same information. For a complete description, see Chapter 2, "Setting Up ODF/36."

- Set the system defaults in the system object distribution profile. The defaults establish the amount of time objects can remain queued to a S/36 user or a remote site, and the level of control your system will have over job streams and spooled print files you receive. The defaults are used to specify if and how job streams or spooled print files are allowed to enter the system. See Chapter 2, "Setting Up ODF/36" and Chapter 4, "Automated and Unattended Operations."

General Information on Sending Objects

When sending information using Object Distribution Facility/36, you must specify the recipient or recipients of the information being sent. You can specify the recipient or recipients in any of the following ways:

- A user on the local system can be specified by a user ID.
- A user on another system is identified by a user ID and a system address.
- One or more users can be identified by using a distribution list. A distribution list can contain both users on the local system as well as users on one or more other systems. The distribution list can be made up of any of the following:

A user ID alone specifies users on the local System/36.

Users on another system require both a user ID and an address.

Lists make it easier to send objects or messages to large numbers of people. They allow you to do such things as create a common distribution list for a group of people.

Note: All user IDs or distribution lists to whom you want to send information must be included in the directory. See "The Directory" on page 1-4 and "Creating Directory Files" on page 2-13.

The total number of recipients for one distribution cannot exceed 150. The total number of recipients is determined by the number of individual user IDs as well as the number of user IDs contained in all the distribution lists included in one send procedure.

For the following reasons, the total number of objects delivered may be different from the number listed in the completion message:

- If a user ID is not defined to the system in the directory at the remote site where the distribution is delivered, the distribution is not sent to that user.
- If an object is sent to a remote system a user ID is specified that is the name of a distribution list on the remote system, the object is delivered to all users in the distribution list that are local users on that remote system. The object is not sent to users on the distribution list that are not local users on that system.

For example, if you specified a distribution list on a Melbourne system that has both Melbourne and Sydney users, only the Melbourne users would receive the object; Sydney users would have to be specified on a list on the Sydney system.

- If the same user ID is contained in more than one distribution list, only one object is sent to that user.

RSCS Parameters

On each Object Distribution Facility/36 SEND procedure, the following RSCS parameters can be specified:

priority specifies the priority used for queueing retransmission at any systems through which the distribution is routed on the way to its destination. Valid priorities are 01 (highest) through 99 (lowest). The default priority is 50.

In a SNADS network, any number from 1 to 49 specifies that the object is sent on the SNADS high priority queue, any number from 50 to 99 specifies that the object is sent on the SNADS low priority queue.

When the object sent is routed through an RSCS network, the priority value as originally specified is passed to RSCS and is used in the RSCS queueing algorithm for each RSCS link the object is routed through.

rscs distribution code specifies the distribution code for objects received on a S/370.

rscs class specifies the class of the distribution. This information is required for certain functions (such as job submission for correct output device selection) at VM or MVS systems.

rscs tag is normally used to specify printer output control information that depends on the specific installation. Consult with your S/370 system administrator if you plan to have output on a S/370.

These parameters are kept with the object and will be sent to RSCS if the object is routed to an RSCS system. If the object is not routed to or through an RSCS system, then the RSCS distribution code, RSCS class, and RSCS tag parameters are ignored by SNADS.

SENDFILE PRIORITY = 25 RSCS CLASS = B

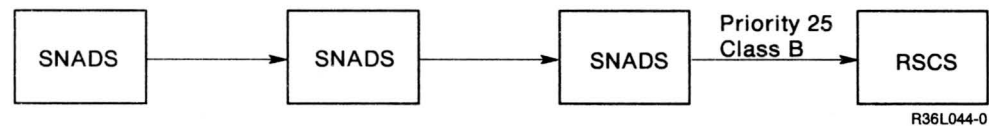

Figure 1-6. RSCS parameters flow through SNADS systems and are sent to RSCS.

SENDFILE PRIORITY = 25 RSCS CLASS = B

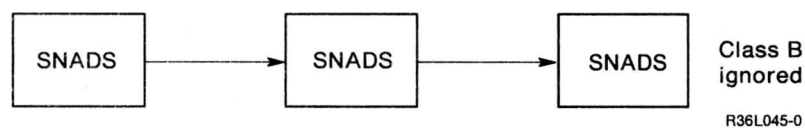

Figure 1-7. RSCS parameters are ignored if the destination is a SNADS system.

Requesting an acknowledgment

S/370 systems send an acknowledgment file, if requested, on the object that was received at the S/370. This acknowledgment file is transformed into the Object Distribution Facility/36 acknowledgment message when it arrives at a System/36.

Chapter 2. Setting Up ODF/36

Before you can use Object Distribution Facility in a network you must do the following:

1. Install the required software on the systems in your network.
2. Initialize the files, communications routes and queues, and directory used by Object Distribution Facility/36.

This chapter explains how to perform steps 1 and 2.

Note: You must also create the communications subsystems and line member definitions to interconnect your systems.

software installation

This section explains in detail how to install the ODF/36 PRPQ and lists the other products that must be installed on your VM/RSCS system and personal computers. For detailed instructions on host and PC software installation refer to the appropriate host or PC manual listed in "About This Manual" on page iii.

VM/RSCS Software Installation

1. Installing the Bridge Line Driver PRPQ

The VM side of the Bridge RSCS line driver for network communication is named DMTVAB.

For VM/RSCS PRPQ P84166 (5799-DAE), follow the installation directions. Refer to this PRPQ for any further information you may require.

The RSCS configuration file must be updated with a new LINK statement for each Bridge line installed. Use line driver type DMTVAB in the LINK statement.

2. Setting Up RSCS on the VM System

As the S/36 administrator, you should exchange information with the VM/370 system administrator to make sure the VM/370 communication is complete.

For more information, refer to the *Remote Spooling Communications Subsystem Networking Reference and Operations Manual*.

The VM/370 system administrator must create the RSCS directory entries by creating link entries for those systems directly attached to the VM system, and creating route entries for those systems that are not directly attached to the VM system.

```

*****
* RSCS CONFIG for RSCS-Bridge example *
*****
LOCAL RSCS 6
*****
* LINK-ID SPECIFICATIONS *
*****
* LINK-ID LINE T/P TIME TASK SPOOL KEEP *
* LINK-ID DRIVER PORT ZONE ID CLASS SLOTS *
LINK MELBSYS S3X 051 6 S01 * 12
*****
* These NODES / USERIDS are authorized to operate RSCS *
*****
AUTH RSCS NETMAINT * CP
*****
* RSCS route specifications *
*****
* NETWORK ROUTES - BEGIN *
* Nodeid Linkid Comments *
* * * * *
ROUTE SYDNSYS MELBSYS
ROUTE ADELSYS MELBSYS
* NETWORK ROUTES _ END
*****
* SUPERVISOR SPECIFICATIONS *
*****
EXEC 3
TAGS 999 Number of tag slots to generate
MSGNOH issue messages using MSGNOH

```

Figure 2-1. RSCS Configuration Sample for Bridge Operation

System/36 Software Installation

The required System/36 communications programs can be installed on System/36 using the CNFIGSSP procedure.

The Object Distribution Facility/36 PRPQ installation is described later in this chapter.

Install the following programs on the System/36s in the network:

- SSP Program Number 5727-SS1 for 5360/5362 or 5727-SS6 for 5363/5364 (Release 5.1 or later).
 - SSP Communications Feature 6001 for 5360/5362 or 6047 for 5363/5364
- Object Distribution Facility/36 PRPQ 5799-CXF for 5360/5362 or PRPQ 5799-CXG for 5363/5364. Installation instructions are provided in this section.

Optionally, install the following:

- Local Area Network (LAN) Support Program Number 5727-LC1
 - PC Support/36 Program Number 5727-WS1 for 5360/5362 or 5727-WS6 for 5363/5364.

Note: You must also install the latest System/36 PTFs available at the time of installation of the Object Distribution Facility/36 PRPQ.

Installing Object Distribution Facility/36

The System/36 Object Distribution Facility PRPQ is shipped on 8-inch diskettes for the 5360 and 5362, and 5-1/4-inch diskettes for the 5363 and 5364. The diskettes contain the Object Distribution Facility/36 programs, the SNADS portion of Personal Services/36, and the subset of ICF BSCEL support needed by Object Distribution Facility/36.

Note: Personal Services/36 and ICF BSCEL are not prerequisites for Object Distribution Facility/36. A subset of both functions is provided with the Object Distribution Facility/36 PRPQ.

To install the PRPQ, you must first copy the file, ODF, from the diskettes into #LIBRARY. If you have volume 1 of the diskettes in slot 1, you can execute the following command on a dedicated system to do the copy as shown below.

```
MAIN
Main System/36 help menu

Select one of the following:

1. Display a user menu
2. Perform general system activities
3. Use and control printer, diskettes, or tape
4. Work with libraries, files, or folders
5. Use programming languages and utilities
6. Communicate with another system or user
7. Define the system and its users
8. Use problem determination and service
9. Use office products
10. Sign off the system

Cmd3-Previous menu  Cmd7-End  Cmd12-How to use help  Home-sign on menu

Ready for option number or command
TOLIBR ODF,I1,,REPLACE,#LIBRARY,S1,AUTO,,ALL,LIBRARY

COPR IBM Corp. 1987
```

Enter the following command:

```
TOLIBR ODF,I1,,REPLACE,#LIBRARY,S1,AUTO,,ALL,LIBRARY
```

Once you have copied ODF into #LIBRARY, you can complete the installation using the ODFLOAD procedure. ODFLOAD has two optional parameters that allow you to specify the starting diskette location and your disk preference for the location of the #OFCLIB library, which is used to contain Personal Services/36 (SNADS). The format of the ODFLOAD procedure is:

```
ODFLOAD [ A1 ] , [ S1 ]
         [ A2 ]   [ S2 ]
         [ A3 ]   [ S3 ]
         [ A4 ]   [ M1.nn ]
                 [ M2.nn ]
```

A1, A2, A3, or A4 specifies the disk unit preference if the library #OFCLIB needs to be created. Specify the disk unit that you want searched first for available disk space. If not enough space is available on that unit, the other units (if they exist) are checked and the library #OFCLIB is placed on the least used disk unit. If no location is specified and the system has more than one disk unit, #OFCLIB is placed on the least used disk unit.

S1, S2, or S3 specifies the diskette slot containing the first diskette to be used. If no diskette position is specified, S1 is assumed.

M1.nn or M2.nn specifies the magazine location containing the first diskette to be used. M1 specifies the first magazine and M2 specifies the second magazine. nn is a decimal value from 01 to 10 that identifies the location of the diskette in the magazine. Specifying M1 is the same as specifying M1.01. Specifying M2 is the same as specifying M2.01.

See "ODFLOAD Procedure" on page 3-42 for more information on the ODFLOAD procedure.

If the installation completes successfully, the following message is displayed:

```
ODF-9800 OPTIONS (0)
Object Distribution Facility/36 has been installed.
```

1. Select option 0 to complete the installation
2. The Object Distribution Facility/36 main menu appears.

```
COMMAND                                ODF/36                                W5

                                Use Object Distribution Facility/36

Select one of the following:

1. Send an object
2. Work with arrived objects
3. Work with messages
4. Perform daily operations
5. Work with directory
6. Work with lists
7. Work with profiles
8. Set up or maintain ODF/36 functions

Cmd3-Previous Menu      Cmd5-Main help menu                COPR IBM Corp. 1988

Ready for option number or command
```

If you receive any other message while installing Object Distribution Facility/36, refer to the *System Messages* manual for more information.

Removing Object Distribution Facility/36

To remove the Object Distribution Facility/36 PRPQ, use the ODFDROP procedure. This procedure, which has no parameters, has the following format:

ODFDROP

ODFDROP should be entered from the System/36 Main menu.

Software Configuration

The topics in this section explain how to:

1. Initialize Object Distribution Facility/36,
2. Initialize Personal Services/36 (SNADS),
3. Define communications queues,
4. Define communications routes,
5. Define directory entries.

Before attempting to initialize Object Distribution Facility/36, you should already know the following:

- The topology of your network
- The names of all of the Systems and personal computers in the network
- The routes that Object Distribution Facility/36 will use to get from one system to another
- The remote location names and session group names of the APPC configurations that interconnect your Systems

Initializing Object Distribution Facility/36

Before you can use Object Distribution Facility/36, you must initialize all of the files and folders used by Object Distribution Facility/36. You can perform these functions from the Object Distribution Facility/36 main menu.

Sign on your System/36. On any menu, type ODF and press the Enter key.

The ODF/36 menu appears.

```
COMMAND                                ODF/36                                W5

                                Use Object Distribution Facility/36

Select one of the following:

1. Send an object
2. Work with arrived objects
3. Work with messages
4. Perform daily operations
5. Work with directory
6. Work with lists
7. Work with profiles
8. Set up or maintain ODF/36 functions

Cmd3-Previous Menu    Cmd5-Main help menu                    COPR IBM Corp. 1988

Ready for option number or command
```

From this display the operator may choose options 1 through 8. Help for each option is available by entering the option number and pressing the Help key.

Options 5, 6, and 8 are described in this chapter.

On the ODF/36 main menu, select option 8 (Set up or maintain ODF/36 functions) and press the Enter key.

The ODFMNT menu appears.

```
COMMAND                                ODFMNT                                W5

                                Set up or maintain Object Distribution Facility/36 functions

Select one of the following:

1. Set up ODF/36 support files and folders
2. Maintain system defaults for ODF/36
3. Set up PS/36 (SNADS) support files and folders
4. Maintain system defaults for PS/36 (SNADS)
5. Maintain PS/36 (SNADS) communication queues
6. Maintain communication routes
7. Maintain remote destinations

Cmd3-Previous menu    Cmd5-Main help menu                    COPR IBM Corp 1988

Ready for option number or command
```

On this display the operator may choose options 1 through 7. Help for each option is available by entering the option number and pressing the Help key.

On the ODFMNT menu, select option 1 (Set up ODF/36 support files and folders) and press the Enter key.

The Create ODF/36 Folder display appears.

Creating the ODF/36 Folder

There is only one folder in Object Distribution Facility/36: #ODFFLDR. The ODF/36 folder contains objects continuing to the next RSCS system, objects that have arrived for users on this system, and ODF/36 profiles.

```
CREATE ODF FOLDER
ODF folder #ODFFLDR

The ODF folder is used to store all objects sent from or arrived for users,
and for all objects sent through this system.
Objects remain in this folder until ODF/36 users receive or delete them,
or until they have remained in the ODF folder the number of days
specified by the object purge interval.

Type choices, press Enter

ITEM                CHOICE    POSSIBLE CHOICES
Number of objects . . . . . 00050    Average (1-32767)
Size of objects in blocks . . . 00010    Average (1-15000)
Number of ODF/36 users. . . . . 0020    Maximum (1-3998)
Will RSCS be used?. . . . . 2       1=Yes 2=No

Cmd3=Go back          Cmd7=End
```

Number of objects: This is the number of objects that are queued to be sent on an RSCS link, or that have arrived for users on this system.

To calculate the number of objects, estimate how many objects you expect to receive from other systems including those you expect to send in from other RSCS systems. The volume of the ODF/36 folder may depend on how long the objects wait in the ODF/36 folder before they are forwarded to the next RSCS system, or are processed by users on this system.

Size of objects in blocks: This is the average number of blocks per object in the ODF/36 folder at any given time.

Number of ODF/36 users: This is the number of users who will have an ODF/36 profile created.

To calculate the number of ODF/36 users, estimate how many users you expect to override the ODF/36 system defaults with their own ODF/36 profile.

Will RSCS be used?: This specifies whether additional space should be allowed for in the folder for RSCS distributions. Answer yes only if this system is directly attached to an RSCS system.

Type in your values, or use the defaults supplied by IBM.

Press the Enter key. The ODF/36 folder is created.

Note: There are performance considerations in sizing the ODF/36 folder. See "Sizing the ODF Folder" on page 7-2 for detailed information on sizing the ODF folder and the performance implications.

```
CREATE ODF FOLDER
ODF folder #ODFFLDR

The ODF folder is used to store all objects sent from or arrived for users,
and for all objects sent through this system.
Objects remain in this folder until ODF/36 users receive or delete them,
or until they have remained in the ODF folder the number of days
specified by the object purge interval.

Type choices, press Enter

ITEM                                CHOICE    POSSIBLE CHOICES
Number of objects . . . . .        Average (1-32767)
Size of objects in blocks . . .    Average (1-15000)
Number of ODF/36 users. . . . .    Maximum (1-3998)
Will RSCS be used?. . . . .        1=Yes 2=No

Cmd3=Go back                        Cmd7=End
** Folder created; press Enter to continue or Cmd7 to End.                ODF-9782
```

Press the Enter key to continue.

The Create Distribution Log File display appears.

Creating the Distribution Log File

There is only one distribution log file in Object Distribution Facility/36: #ODFLOGF. The distribution log records the status of all objects in the ODF folder. Entries are created each time an object is sent, arrives, is deleted, received, distributed, or an error occurs. The distribution log file will wrap when it fills.

The distribution log should be large enough to keep track of activity over a period until you can be sure the objects have been properly handled.

```

                                CREATE DISTRIBUTION LOG FILE
Distribution log file #ODFLOGF

The distribution log is used to record the status of objects in the
ODF folder. An entry is created in the log each time an object is
sent, received, deleted, distributed, arrives, or an error occurs.
The distribution log file will wrap when it fills.

Type choices, press Enter

ITEM                                CHOICE    POSSIBLE CHOICES
Number of entries . . . . . 00000200 Maximum (1-8000000)

Cmd3=Go back                        Cmd7=End

```

Type in your number of entries, or use the default supplied by IBM.

Press the Enter key. The distribution log file is created.

```

                                CREATE DISTRIBUTION LOG FILE
Distribution log file #ODFLOGF

The distribution log is used to record the status of objects in the
ODF folder. An entry is created in the log each time an object is
sent, received, deleted, distributed, arrives, or an error occurs.
The distribution log file will wrap when it fills.

Type choices, press Enter

ITEM                                CHOICE    POSSIBLE CHOICES
Number of entries . . . . . 00000200 Maximum (1-8000000)

Cmd3=Go back                        Cmd7=End

** File created; press Enter to continue or Cmd7 to End.
ODF-9782

```

Press the Enter key to continue.

The Maintain ODF/36 Defaults display appears.

Object Distribution Facility/36 Defaults

The Object Distribution Facility/36 defaults contain the system-wide default values. When you define the Object Distribution Facility/36 defaults, the Object Distribution Facility/36 system profile is created. This same display is used later to maintain your Object Distribution Facility/36 defaults.

```

                                MAINTAIN ODF/36 DEFAULTS
These values apply to everyone using ODF/36 on your S/36.

Type choices, press Enter

ITEM                                CHOICE  POSSIBLE CHOICES

System values:
Object purge interval in days . . .  _      Maximum (10-180)
Restrict ODFPROF procedure. . . . . _      1=Yes 2=No

User values:
Automatically submit jobs? . . . . . _      1=Yes 2=No 3=Match
Automatically print spool files? . . _      1=Yes 2=No
Printer ID. . . . . _                      ID, SYSTEM
Forms . . . . . _                          1-255
Copies. . . . . 000                        0-5
Priority. . . . . _                          1=Yes 2=No
Object arrival message? . . . . . _

Cmd7=End
** Default not set. Type choices, press Enter to create          ODF-9752

```

Object purge interval in days: This is the maximum number of days an object that has not been processed should be kept on your system. When an object in the ODF folder has not been processed (sent on an RSCS link, or processed by a user on this system) for the number of days specified by the purge interval, it will be deleted from the ODF folder by the ODFIPL procedure.

Specify a value suitable for your system. This "automatic purge" function can assist in managing disk space used on the system.

Restrict ODFPROF procedure?: Users can override the user values in the ODF/36 system profile by creating their own ODF/36 profiles with the ODFPROF procedure. Specify 1 (Yes) if you do not want users to be able to create their own ODF/36 profiles; only a user of security officer authority, or higher, will be allowed to run the ODFPROF procedure. Specify a 2 (No) if you do not want to restrict the usage of the ODFPROF procedure.

The following values can be overridden by users who create their own ODF/36 profile:

Automatically submit jobs?: Defines how job streams received from other systems should be processed.

Number Definition

- 1 (Yes) Specifies that job streams should be submitted automatically by Object Distribution Facility/36.
- 2 (No) Specifies that job streams should not be submitted; the job stream will be placed in the user's list of arrived objects.

3 (Match) Specifies the job is to be submitted if the sending and receiving user IDs match; the job stream will be placed in the user's list of arrived objects if the user IDs do not match.

Automatically print spool files?: Defines how spooled print files received from other systems should be processed.

Number Definition

1 (Yes) Specifies that spooled print files should be printed automatically by ODF/36.

2 (No) Specifies that spooled print files should not be printed automatically; the spooled print file will be placed in the users list of arrived objects.

Printer Id: Defines which printer is to be used for automatically printing spooled print files.

Forms: Defines the forms number to be used for automatically printing spooled print files.

Copies: Defines the number of copies to be printed for automatically printing spooled print files.

Priority: Defines the priority of spooled output for automatically printing spooled print files. The priority can be any decimal number from 0 through 5. The system prints spool file entries with higher priority numbers before jobs with lower priority numbers. For example, all printed output with a priority of 5 is printed before any other spool file entries. Spool file entries with the same priority are printed in the order that they were placed on the spool file. Priority 1 entries are the last entries printed by the system.

Priority 0 entries are placed on the spool file with a priority of 1 and are held. These entries are not printed until a **RELEASE** control command is entered.

Object Arrival Message?: Defines if Object Distribution Facility/36 should send an *Object has arrived* message each time an object arrives for a user on this system.

Number Definition

1 Specifies that a message should be sent each time an object arrives for a user on this system.

2 Specifies that a message should not be sent.

Type in your default values.

Press the Enter key. The Object Distribution Facility/36 system profile is created.

MAINTAIN ODF/36 DEFAULTS

These values apply to everyone using ODF/36 on your S/36.

Type choices, press Enter

ITEM	CHOICE	POSSIBLE CHOICES
System values:		
Object purge interval in days . . .		Maximum (10-180)
Restrict ODFPROF procedure.		1=Yes 2=No
User values:		
Automatically submit jobs?		1=Yes 2=No 3=Match
Automatically print spool files? . .		1=Yes 2=No
Printer ID.		ID, SYSTEM
Forms		
Copies.		1-255
Priority.		0-5
Object arrival message?		1=Yes 2=No

Cmd7=End

**** Defaults set; press Enter to continue or Cmd7 to end**

ODF-9784

Press the Enter key to complete ODF/36 initialization.

Initializing Personal Services/36 (SNADS)

```
COMMAND                                ODFMNT                                W5

      Set up or maintain Object Distribution Facility/36 functions

Select one of the following:

1. Set up ODF/36 support files and folders
2. Maintain system defaults for ODF/36
3. Set up PS/36 (SNADS) support files and folders
4. Maintain system defaults for PS/36 (SNADS)
5. Maintain PS/36 (SNADS) communication queues
6. Maintain communication routes
7. Maintain remote destinations

Cmd3-Previous menu  Cmd5-Main help menu                                COPR IBM Corp 1988

Ready for option number or command
```

On the ODFMNT menu, select option 3 (Set up PS/36 (SNADS) support files and folders) and press the Enter key.

The Create Directory Files display appears.

Note: If Personal Services/36 is currently installed on the system, then additional files and folders are prompted by the following procedure. Also, the order of the displays for file and folder creation may be different. Only the files and folders used by Object Distribution Facility/36 are shown in this section.

Creating Directory Files

There is only one primary directory file in Personal Services/36 (SNADS): \$OUDRFL. It allows you to keep a file of names and addresses of individuals, companies, or organizations, along with other information about these entries. There is another directory file called the *alternative indexed file (\$OUDRAL)*. This file allows the user to view the records in the primary directory file in a different order.

You can view the entire directory or search for individual names in the directory. You can also view the directory information about people within a list.

Object Distribution Facility/36 and Personal Services/36 (SNADS) also use the directory for distribution.

```

                                CREATE DIRECTORY FILES
DIRECTORY FILE                $OUDRFL
ALTERNATIVE INDEXED FILE     $OUDRAL

The directory file has an entry for each user.
Each entry contains name and address and other information. You can put
information about other people in the directory also.

The first file, $OUDRFL, contains the directory records and the
primary index. The second file, $OUDRAL, contains an alternative
index for the directory.

Type choice, press Enter
ITEM          CHOICE          POSSIBLE CHOICES
Number of entries. . . . . 00500          Maximum 1-99999

Cmd3=Go back          Cmd5=Secure files          Cmd7=Quit

                                COPR IBM Corp. 1987

```

Number of entries: This number is the number of entries in the directory at any given time.

To calculate the number of entries, first decide the following:

Number of users: Decide how many users you want to identify in your directory.

A user in the directory file can be:

- An Object Distribution Facility/36 user
- A PC location

There can be another user you may want to put in in your directory:

- An organization that is currently on your company's distribution list
- A user at a remote system

If you send objects or messages to remote locations, you need directory entries that enable these users to be located.

For example, suppose you have 30 people at your system who will be using Object Distribution Facility/36. These 30 people are your Object Distribution Facility/36 users. Another five people operate PCs on the IBM Token Ring. These five people are PC locations. Ten businesses are currently on your company's distribution list. Include these organizations in your directory list. Fifty people at remote systems exchange objects or messages with your system. These fifty people are users at remote systems. All 95 users require directory entries. (30 Object Distribution Facility/36 Users + 5 PC locations + 10 organizations + 50 users at remote systems = 95 users.)

Users at remote systems can be Object Distribution Facility/36 users, remote PC locations, and users of other types of systems. If you are going to send objects to other systems, you must include them in the directory of the remote system.

Note: PC locations cannot send or receive objects using Object Distribution Facility/36. They can only send and receive messages.

Other ways of setting up the directory: You can set up the directory in four ways on your system to allow communications with users at remote systems:

- Create an entry for each user of each remote system.
- Create an entry for each address at each remote system. This is called a *remote destination* entry.
- Create entries for some or all users at remote systems, and create entries for addresses.
- Create one entry for all undefined addresses and user IDs so that objects can be routed to this system.

A Remote Destination entry lets you send objects to a remote system without specifying each user ID in the directory at your system.

For example, suppose your system communicates with one in Sydney, one in Adelaide, and one in Perth. Suppose you have 50 users at the system in Sydney (SYDNSYS) and another 50 users at the system in Adelaide (ADELSYS). There are also 50 VM/RSCS users in Perth (PERTVM) that you communicate with. Instead of setting up 150 directory entries, each with unique user IDs, you can set up three remote destination entries as follows:

Address	System	PROFS	DLS
SYDNSYS	SYDNSYS	No	No
ADELSYS	ADELSYS	No	No
PERTVM	PERTVM	No	No

Figure 2-2. Remote Destination Entries in the Directory

Note: The *PROFS* and *DLS* parameters are not used by Object Distribution Facility/36. The *PROFS* parameter should never be set.

The use of a remote destination entry saves maintenance on large directories. If you are planning a small System/36 network, you can simply set up a directory entry for each user of a remote system. To get a complete list of users, you can contact the administrators at all the remote systems.

For instance, using the above example in your directory you would have 50 users at the system in Sydney (SYDNSYS), 50 users at the system in Adelaide (ADELSYS) and 50 VM/RSCS users in Perth (PERTVM). Your directory at the Melbourne system (MELBSYS) would look something like this:

User ID	Address	System
BECKY	SYDNSYS	SYDNSYS
JERRY	SYDNSYS	SYDNSYS
.	.	.
.	.	.

Figure 2-3 (Part 1 of 2). Directory for Users at Remote Systems

User ID	Address	System
.	.	.
JEFF	ADELSYS	ADELSYS
PAUL	ADELSYS	ADELSYS
PETE	ADELSYS	ADELSYS
.	.	.
.	.	.
TERRY	PERTVM	PERTVM
.	.	.

Figure 2-3 (Part 2 of 2). Directory for Users at Remote Systems

Even if you create directory entries for everyone at the remote systems, you may still create remote destination entries. Then objects can be sent to new users at these systems before you update your directory.

Type in your number of entries, or use the IBM default.

Press the Enter key. The directory files are created.

```

                                CREATE DIRECTORY FILES
    DIRECTORY FILE                $OUDRFL
    ALTERNATIVE INDEXED FILE     $OUDRAL

    The directory file has an entry for each user.
    Each entry contains name and address and other information. You can put
    information about other people in the directory also.

    The first file, $OUDRFL, contains the directory records and the
    primary index. The second file, $OUDRAL, contains an alternative
    index for the directory.

    Type choice, press Enter
    ITEM                           CHOICE      POSSIBLE CHOICES
    Number of entries. . . . . 00500      Maximum 1-99999

    Cmd3=Go back      Cmd5=Secure files      Cmd7=Quit
                                COPR IBM Corp. 1987
    **File created; Cmd7 to quit or Enter to continue
  
```

If you do not see Cmd5=Secure files on your display, resource security is not active on your System/36.

If resource security is active on your System/36, you can press Cmd5 to secure the file. The SSP resource security display is shown. For more information on resource security, press Help and use the *System Security Guide*.

The recommended **default** access to this file is **READ**, with **UPDATE** access for some selected users. Give **READ** access to any users who need to view or print the

directory entries. Give UPDATE access to any users who need to add, change, or delete directory entries.

Note: Make sure you define the same access level for both \$OUDRFL and \$OUDRAL. If resource security is active, specify the \$OUDRAL file as an alternative index and specify the \$OUDRFL file as its primary file.

Press the Enter key to continue.

The Create List File display appears.

Creating the List File

There is only one list file in Personal Services/36 (SNADS): \$OUGRFL. A list is a collection of people or items identified under a single name. Lists make it easier to send objects or messages to many people. They allow you to do such things as create a common distribution list for a group of people.

You can create lists that include individuals or lists from other systems and PC locations.

An example of a list might be a department. Suppose you are in a payroll department. This department name identifies a list.

All of the people in this department are represented by list items. A list can represent a distribution list for objects, or a personalized directory. Users are likely to create several lists for their own individual uses.

```

                                CREATE LIST FILE
LIST FILE      $OUGRFL

A list is a collection of items that are to be known together by a
single
name. The items within a list may refer to a user identifier, calendar
or another list.

All lists are stored in a list file. Make the file large enough
to hold all of the lists.

Type choice, press Enter
ITEM          CHOICE          POSSIBLE CHOICES
Number of lists . . . . . 100          Maximum 1-999
Items per list . . . . . 010          Average 1-150

Cmd3=Go back      Cmd5=Secure file      Cmd7=Quit

                                COPR IBM Corp. 1987
```

Number of lists: This is the number of lists in your list file at any given time.

To calculate the number of list records you have, estimate how many list records each user will want and multiply this number by the number of Object Distribution Facility/36 users you have. For example, if you have 30 Object Distribution

Facility/36 users and you estimate that each one will create on average three lists, you need 90 list records.

Items per list: This is the average number of items per list in your list file at any given time.

To calculate the number of items per list, first decide how many names you want to put in each list. Look at the names and addresses on your current organization lists.

Estimate the number of names per list, or use the default provided by IBM.

Type in your number of lists and the average number per list.

Press the Enter key. The list file is created.

```

                                CREATE LIST FILE
LIST FILE      $OUGRFL

A list is a collection of items that are to be known together by a
single
name. The items within a list may refer to a user identifier, calendar
or another list.

All lists are stored in a list file. Make the file large enough
to hold all of the lists.

Type choice, press Enter
ITEM          CHOICE          POSSIBLE CHOICES
Number of lists . . . . . 100          Maximum 1-999
Items per list . . . . . 010          Average 1-150

Cmd3=Go back      Cmd5=Secure file      Cmd7=Quit

                                COPR IBM Corp. 1987
**File created; Cmd7 to quit or Enter to continue
```

If you do not see Cmd5 = Secure file on your display, resource security is not active on your System/36.

If resource security is active on your System/36, you can press Cmd5 to secure the file. The SSP resource security display is shown. For more information on resource security, press Help and use the *System Security Guide*.

The recommended **default** access to this file is **READ**, with **UPDATE** access for selected users. Give **READ** access to users who need to view or print the lists. Give **UPDATE** access to users who need to add, change, or delete lists.

Press the Enter key to continue.

The Create Mail Information File appears.

Creating the Mail Information File

There is only one mail information file for Personal Services/36 (SNADS): \$OUMLTAB . The mail information file keeps a record of all communications routes and communications queue definitions used to sort and send objects to remote systems.

```
CREATE MAIL INFORMATION FILE
MAIL INFORMATION FILE      $OUMLTAB

This file is used by PS/36 to store information about users and systems
that will send and receive mail.

The size of this file depends on the maximum number of users who will
send and receive mail, and the number of systems with which your S/36
communicates.

Type choice, press Enter
ITEM          CHOICE      POSSIBLE CHOICES
Number of users. . . . . 020      Maximum 1-999
Number of systems. . . . . 000      Maximum 0-999

Cmd3=Go back      Cmd5=Secure file      Cmd7=Quit

COPR IBM Corp. 1987
```

Number of users: Estimate the number of Object Distribution Facility/36 users who will send objects. IBM also supplies a default value. For example, if you have 30 Object Distribution Facility/36 users, enter 30.

Number of systems: If you are not going to send objects to remote systems, use the default supplied by IBM.

This number is the number of other systems in your mail information file. Other systems can be a System/36 with Object Distribution Facility/36, a System/370, a System/38, or an AS/400 system.

Calculate the number of other systems to which you will send objects and from which you will receive objects.

For example, suppose there is a system in Melbourne, a system in Sydney, a system in Adelaide, and a system in Perth. If you are at the Melbourne system, Sydney, Adelaide, and Perth are the three other systems in the network. There are three other systems that Melbourne can send objects to and receive objects from.

Type in your number of users and your number of systems, or use the IBM supplied defaults.

Press the Enter key. The mail information file is created.

```

CREATE MAIL INFORMATION FILE
MAIL INFORMATION FILE      $OUMLTAB

This file is used by PS/36 to store information about users and systems
that will send and receive mail.

The size of this file depends on the maximum number of users who will
send and receive mail, and the number of systems with which your S/36
communicates.

Type choice, press Enter
ITEM          CHOICE      POSSIBLE CHOICES
Number of users. . . . . 020      Maximum 1-999
Number of systems. . . . . 000      Maximum 0-999

Cmd3=Go back      Cmd5=Secure file      Cmd7=Quit

COPR IBM Corp. 1987

**File created; Cmd7 to quit or Enter to continue

```

If you do not see Cmd5 = Secure file on your display, resource security is not active on your System/36.

If resource security is active on your System/36, you can press Cmd5 to secure the file. The SSP resource security display is shown. For more information on resource security, press Help and use the *System Security Guide*.

The recommended **default** access to this file is NONE.

Press the Enter key to continue.

The Create Mail Queue File display appears.

Creating the Mail Queue File

There is only one mail queue file in Personal Services/36 (SNADS): \$OUMLQ. The mail queue file keeps track of all objects sent or received within your system or sent to other systems. Objects sent locally and arrived objects do not stay on the queue very long. Objects sent to remote systems may wait some time, depending on the communication queue characteristics, such as send length, retry interval, and purge interval.

Since there may be a lot of activity in \$OUMLQ, you should consider reorganizing \$OUMLQ daily. You can use the **copydata** procedure to do so. You can reorganize this file only when Personal Services/36 (SNADS) is not being used.

To run the copydata procedure, type

- **COPYDATA \$OUMLQ,,NEWNAME,,,,T,REORG**

on the command line. NEWNAME is a user defined name you provide for the organized file.

After using the **copydata** procedure, delete the original file \$OUMLQ and then rename the reorganized file to \$OUMLQ. For more information on the COPYDATA procedure, see the *System Reference* manual. If you want, you can

make this procedure part of the IPL procedure. For a complete description of how to make a procedure part of IPL, see the *Operating Your Computer* manual.

```
CREATE MAIL QUEUE FILE
MAIL QUEUE FILE      $OUMLQ

This file is used by mail functions for document queues. The queues are
used to keep track of mail that must be sent to local users, other
systems, and independent work stations.

The size of this file depends on the maximum number of 'send' requests
that have not been completed.

Type choice, press Enter
ITEM          CHOICE      POSSIBLE CHOICES
Undelivered requests . . . 020      Maximum 1-9999

Cmd3=Go back      Cmd5=Secure file      Cmd7=Quit

COPR IBM Corp. 1987
```

Undelivered requests: This is the number of undelivered send requests in the mail queue file at any given time.

An undelivered send request is an object sent to a user at a remote system but not yet forwarded from your system. The entry for this object is kept in the queue until it is forwarded to the next system in the communications network.

Estimate how many objects you expect to send to other remote systems and how long they will wait on the send queues before being sent, or use the default supplied by IBM.

Type in your number of undelivered requests.

Press the Enter key. The mail queue file is created.

```

                                CREATE MAIL QUEUE FILE
MAIL QUEUE FILE                $OUMLQ

This file is used by mail functions for document queues. The queues are
used to keep track of mail that must be sent to local users, other
systems, and independent work stations.

The size of this file depends on the maximum number of 'send' requests
that have not been completed.

Type choice, press Enter
ITEM                CHOICE                POSSIBLE CHOICES
Undelivered requests . . . 020                Maximum 1-9999

Cmd3=Go back        Cmd5=Secure file        Cmd7=Quit

                                COPR IBM Corp. 1987
**File created; Cmd7 to quit or Enter to continue

```

If you do not see Cmd5 = Secure file on your display, resource security is not active on your System/36.

If resource security is active on your System/36, you can press Cmd5 to secure the file. The SSP resource security display appears. For more information on resource security, press Help and use the *System Security Guide*.

The recommended **default** access to this file is NONE.

Press the Enter key to continue.

The Create Storage Folder display appears.

Creating the Storage Folder

There is only one storage folder in Personal Services/36 (SNADS): \$OUSSFL. The storage folder contains objects continuing to the next SNADS system. Objects identified as belonging to your system, or continuing to the next RSCS system, are placed in the ODF folder (#ODFFLDR). All other objects are forwarded to the next system.

Note: Personal Services/36 uses the terms **Documents** and **Number of pages** in sizing the storage folder. These relate directly to **Objects** and **Size of objects in blocks** in this manual.

```

CREATE STORAGE FOLDER
STORAGE FOLDER $OUSSF

This folder is used to store documents received from one location
for forwarding to another location in the data communications network.
A document is kept in this folder from the time it is received until
it has been sent to the next location on its route.

The size of this folder depends on the maximum number of documents
it must contain and the average document size. If this
System/36 does not act
as an intermediate point in the network, specify 0 for the number of
documents and the folder will not be created.

Type choice, press Enter
ITEM                CHOICE        POSSIBLE CHOICES
Number of documents . . . . . 050          Maximum 1-9999
Number of pages . . . . . 005          Average 1-999

Cmd3=Go back      Cmd5=Secure folder      Cmd7=Quit

```

Number of documents: This is the number of objects in your storage folder at any given time.

To estimate the number of objects in the storage folder, determine how many objects you expect to send in from other systems. The volume of the storage folder may depend on how long the objects wait in the storage folder before they are forwarded to the next system.

Number of pages: This is the average number of blocks per object in the storage folder at any given time.

To estimate the blocks per object, use the number you calculated in *Size of objects in blocks* for the ODF/36 folder. If you entered twenty blocks per object there, enter twenty blocks per object here.

Type in your number of objects (number of documents) and your size of objects in blocks (number of pages).

Press the Enter key. The storage folder is created.

Note: The storage folder must always be created for Object Distribution Facility/36, even if your system is not an intermediate point in the network.

```

CREATE STORAGE FOLDER
STORAGE FOLDER      $OUSSFL

This folder is used to store documents received from one location
for forwarding to another location in the data communications network.
A document is kept in this folder from the time it is received until
it has been sent to the next location on its route.

The size of this folder depends on the maximum number of documents
it must contain and the average document size. If this
System/36 does not act
as an intermediate point in the network, specify 0 for the number of
documents and the folder will not be created.

Type choice, press Enter
ITEM                CHOICE      POSSIBLE CHOICES
Number of documents . . . . . 050      Maximum 1-9999
Number of pages . . . . . 005      Average 1-999

Cmd3=Go back      Cmd5=Secure folder      Cmd7=Quit

**Folder created; Cmd7 to quit or Enter to continue

```

If you do not see Cmd5=Secure folder on your display, resource security is not active on your System/36.

If resource security is active on your System/36, you can press Cmd5 to secure the folder. The SSP resource security display is shown. For more information on resource security, press Help and use the *System Security Guide*.

The recommended **default** access to this folder is NONE.

Press the Enter key to continue.

The Maintain Distribution Defaults display appears.

Personal Services/36 (SNADS) Defaults

The Personal Services/36 (SNADS) defaults contain the system-wide default values. When you define the Personal Services/36 (SNADS) defaults, the Personal Services/36 (SNADS) profile record is created. This same display is used later to maintain your Personal Services/36 (SNADS) defaults.

```

                                MAINTAIN DISTRIBUTION DEFAULTS
These values apply to everyone using distribution function on your S/36.
Type choices, press Enter.
ITEM          CHOICE          POSSIBLE CHOICES
System-wide values:
Address . . . . . MELBSYS      Used for distribution
System . . . . . MELBSYS      System name
Distribution . . . . . 1        1=Normal    2=Expedite

                                Cmd3=Go back      Cmd7=Quit      Cmd8=Redisplay

```

Note: A different display is presented if Personal Services/36 is currently installed. Only the above three parameters are used by Object Distribution Facility/36.

System-Wide values

These are values associated with your System/36. They cannot be changed for individual users.

Address: Choose the default address for your system which is specified in your CNFIGICF. The default address is the address given to any user by Personal Services/36 (SNADS) when a blank address is entered as a directory entry. Users can send objects to other users on the same system without specifying an address.

The address can be any eight characters, uppercase, A-Z, 0-9, except commas (,), single quotation marks ('), question marks (?), slashes (/), hyphens (-), and blanks. Special characters \$, #, and @ can be used.

The address makes the user ID unique within the network for sending objects. You can choose an address that is different from the system name, however if there are S/370 systems in your network, the address must be the same as the system name for compatibility with S/370 RSCS networking. The address helps direct objects to your system. Since users enter an address when they send objects, you should make the address easy to remember. This way you avoid distribution problems. An address, for example, can be a location, as in MELBSYS (Melbourne system) or a division, as in HEADOFCE (Head office).

You must specify an address that can be used for all the users in your office.

For example, suppose your address is MELBSYS. When local or remote objects are sent to your location, the address identifies your system. The address, along with the system name, ensures that all objects sent to your office or within your office reach their destination. Assignment of addresses must be coordinated with the administrators of systems in the network.

You can only have one address per system using Object Distribution Facility/36.

System: Choose the system name of your computer as specified in your CNFIGICF. The system name can be any eight characters in length, uppercase, A-Z, 0-9, except commas (,), single quotation marks ('), question marks (?), slashes (/), hyphens (-), and blanks. Special characters \$, #, and @ can be used.

The name of your system should be unique in the communications network. Administrators at other systems in the communication network need to know your system name if they are to send objects to you. Choose a system name that is meaningful and easy to remember. The system name is used for both local and remote objects.

For example, suppose your system name is MELBSYS (Melbourne system). When local or remote objects are sent to your location, the system's name MELBSYS identifies your system. This identification is one way of ensuring that all objects sent to your office or within your office reaches their destination.

Distribution: Choose the default priority for the Personal Services/36 (SNADS) jobs that perform distribution. You have two choices. With 1 (Normal priority), these jobs run at the normal priority. With 2 (Expedite), these jobs run at a higher priority than normal. The expedite option may affect interactive user response time.

Type your distribution values.

Press the Enter key. The Personal Services/36 (SNADS) defaults record is created.

What to do next: Now that you have completed the set up, you can add your route and queue definitions.

Defining Communications Routes and Queues

The remote location and session group pairs (if applicable) that Personal Services/36 (SNADS) uses can be taken directly from the advanced program-to-program communications (APPC) subsystem or the advanced peer-to-peer networking (APPN) subsystem or the name of the attached RSCS systems.

Note: No user-created configuration subsystems are required to communicate with RSCS.

To tell the system programmer what information you require to set up Personal Services/36 (SNADS) routes and queues, you need to know how the following terms correspond to each other:

PS/36 Term	APPC Term	RSCS Term
System	Remote System	RSCS system name
Remote location	Remote location name	RSCS system name
Session group	Session group name	(not applicable)

Figure 2-4. How PS/36 (SNADS) Terms Correspond to APPC and RSCS Terms

The APPC subsystem is an Interactive Communications Feature (ICF) that the system programmer configures using the CNFIGICF procedure. For more information on the APPC subsystem support for Personal Services/36 (SNADS), see the *Using System/36 Communications* manual.

A Personal Services/36 (SNADS) route is defined by up to three remote location, session group pairs for a SNADS attached system or a remote location for an RSCS attached system. For more information on these terms, see the *Using System/36 Communications* manual.

Setting Up Communications Routes

In this section, you determine the communications routes to send objects, messages, or status information to other systems.

Add a Communications Route

You need the information in this step to add a communications route for each system to which you will send objects. The communication lines to each SNADS system should already be defined in your APPC or APPN subsystem for your System/36 network. See your system programmer to be sure.

If you plan to communicate with RSCS, you do not have to create a CNFIGICF line or subsystem member. These are created for you by ODF/36 when you start communications with RSCS.

A route is a communication path from your system to another system. Personal Services/36 (SNADS) lets you have only one route to a remote system, but Personal Services/36 (SNADS) allows you to send objects in different ways along that route by defining different queues for the route. When you add a route to Personal Services/36 (SNADS), you specify the remote system name and the queues you want to use with that route.

You need at least one queue for each route you add. If you have one queue, status information (priority level 0) is sent before high priority objects. Objects in the high priority (level 1) are sent before normal priority (level 2) objects. For setting up the routes to RSCS, there are no priority levels. You can have more than one queue for a route for objects of different priorities (except for a route to RSCS). If you have more than one queue, objects sent are based on how you define your queues.

The following is an example of the Add Communications Route display. How to access this display will be shown later in this section.

```

                                ADD COMMUNICATIONS ROUTE
Type choices, press Enter.
ITEM          CHOICE          POSSIBLE CHOICES
SYSTEM. . . . . _____  Name of remote system

Via APPC or APPN communications
Priority      2                2 is for normal priority mail
Remote location. . . _____  as defined using CNFIGICF
Session group . . . _____  as defined using CNFIGICF
Priority      1                1 is for high priority mail
Remote location. . . _____
Session group . . . _____
Priority      0                0 is for status information
Remote location. . . _____
Session group . . . _____

Via BSC/MSRJE communications or
via BSC MSRJE for PROFS bridge
Remote location. . . _____  As defined using CNFIGICF

Cmd3=Go back          Cmd7=Quit

```

You need the following information for each system you want to send objects to:

System

This is the name of the remote system. The name of the remote system is an identification label for any other system to which you are connected.

For example, if your system needs to send objects to Sydney, Adelaide, and Perth, you would define three remote system names. They could be SYDNSYS, ADELSYS, and PERTVM. When users send objects to SYDNSYS, Personal Services/36 (SNADS) uses the remote system name to make sure the objects reach their destination. The administrator of the remote system must provide you with the name of the remote system. If the remote system is another System/36, the name is the one the administrator of that system entered on the Maintain Distribution Defaults display.

If you want to communicate with RSCS, you will have to ask the RSCS Administrator of that system for the system name.

A special value '*' is allowed in this prompt. This value means that if there is no route to a specific system defined, the distribution will take place through this route. In other words, you do not have to define all routes explicitly to every system in the network. You can define one route under this special name to channel the distribution. You must specify an APPC definition and not RSCS for this special route.

When communicating with RSCS, the system name is the same as the node ID.

Via APPC or APPN communications

Priority

Priority controls the way objects in a queue are sent to other systems. When you send an object, you can choose a priority for that object, either normal (50-99) or high (1-49). High priority is like sending air mail. Normal priority is like sending surface mail. You can set up your route to a system so that objects go to different queues, depending on the priority given by a user. Define one queue for high priority, and another queue for normal priority.

Note: You must have one queue with normal priority per route.

Personal Services/36 (SNADS) defines the high priority queue as priority 1, and the normal priority queue as priority 2.

When your system receives objects from another system, Personal Services/36 (SNADS) sends back status information and system messages to that system along the route. You can define a separate queue for status information with priority 0.

Up to three queues are possible for a route, one for each priority: normal, high, and status. Three queues allow greater flexibility in tuning, as you will be able to adjust separately the send length, retry interval, and purge interval for status information, high, and normal priority objects. Also, if you use dial-up lines, you might allow status and priority objects to be sent during the day, keeping normal priority objects until night when telephone rates are often lowest.

Figure 2-5 shows the queue priorities and how they are selected by the ODF/36 send procedures.

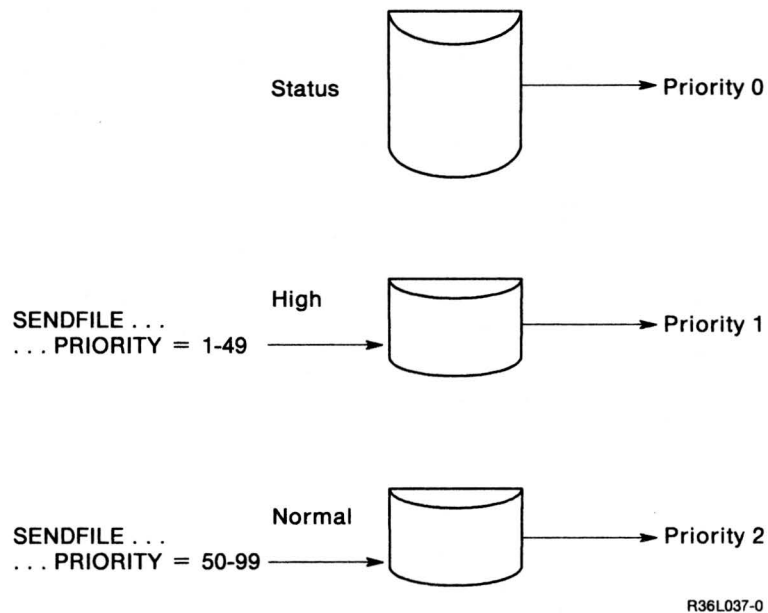

Figure 2-5. Queue Priorities

For example, you can define your three queues so that high priority objects are sent when five objects enter the queue, normal priority objects can be held in the queue until line rates are cheaper, and status information can be sent when one piece of

status information enters the queue (so sending or receiving systems are immediately informed when network problems arise).

Note: When sending to RSCS, priority is not used in queue selection, because there is only one queue for each RSCS link. Objects for RSCS systems are placed in the ODF/36 folder and are sent by Object Distribution Facility/36.

Remote location, Session group pair

In Personal Services/36 (SNADS), the remote location, session group pair identifies a queue. Each route can have up to three different queues between two systems. Queues contain entries for objects, messages, and status information waiting to be sent from your system to other systems. When you assign queues to your routes, you define how objects will be sent along the route. When you add your queue definitions, you define how often objects are sent.

The remote location, session group pairs to each system should already be set up in APPC when the system programmer configured the Interactive Communications Feature. Ask the system programmer to give you only the remote location, session group pairs that Personal Services/36 (SNADS) needs to send objects to other systems in the network.

For example, if you are at MELBSYS system and you set up your routes as shown in Figure 2-6 on page 2-32, your routes would look as follows:

System ADELSYS	System SYDNSYS
Queue priority 2	Queue priority 2
Remote location ADEL	Remote location SYDN
Session group NORMAL	Session group COMMON
Queue priority 1	Queue priority 1
Remote location ADEL	Remote location SYDN
Session group HIGH	Session group COMMON
Queue priority 0	Queue priority 0
Remote location ADEL	Remote location SYDN
Session group STATUS	Session group COMMON

By comparison, the Adelaide system (ADELSYS) has the routes defined as follows:

SYSTEM MELBSYS	SYSTEM SYDNSYS
Queue priority <i>2</i>	Queue priority <i>2</i>
Remote location <i>MELB</i>	Remote location <i>MELB</i>
Session group <i>NORMAL</i>	Session group <i>NORMAL</i>
Queue priority <i>1</i>	Queue priority <i>1</i>
Remote location <i>MELB</i>	Remote location <i>MELB</i>
Session group <i>HIGH</i>	Session group <i>HIGH</i>
Queue priority <i>0</i>	Queue priority <i>0</i>
Remote location <i>MELB</i>	Remote location <i>SYDN</i>
Session group <i>STATUS</i>	Session group <i>STATUS</i>

Notice that objects go to Melbourne from Adelaide first before they go to Sydney, as shown by the remote location, session group pairs MELB NORMAL and MELB HIGH for SYDNSYS, and status information goes from Adelaide to Sydney (SYDN STATUS) for SYDNSYS.

Via BSCCEL communications

This is only applicable if you plan to communicate with RSCS via the subset of ICF BSCCEL communications provided by Object Distribution Facility/36. The section under **Via APPC or APPN communications** must be blank.

Remote location

Suppose you want to set up a route to a VM/RSCS system in Perth (PERTVM). The remote location here must always be the same as the RSCS system name (node ID). The route for this example would be set up as follows.

SYSTEM PERTVM
Queue priority ____
Remote location <i>PERTVM</i>
Session group ____
Queue priority ____
Remote location ____
Session group ____
Queue priority ____
Remote location ____
Session group ____

Note: The Priority and Session Group are left blank.

In the example, there is a Melbourne system (MELBSYS) and three other systems: one in Adelaide (ADELSYS), one in Sydney (SYDNSYS), and the other in Perth (PERTVM). The routes for this example could be set up as shown in Figure 2-6:

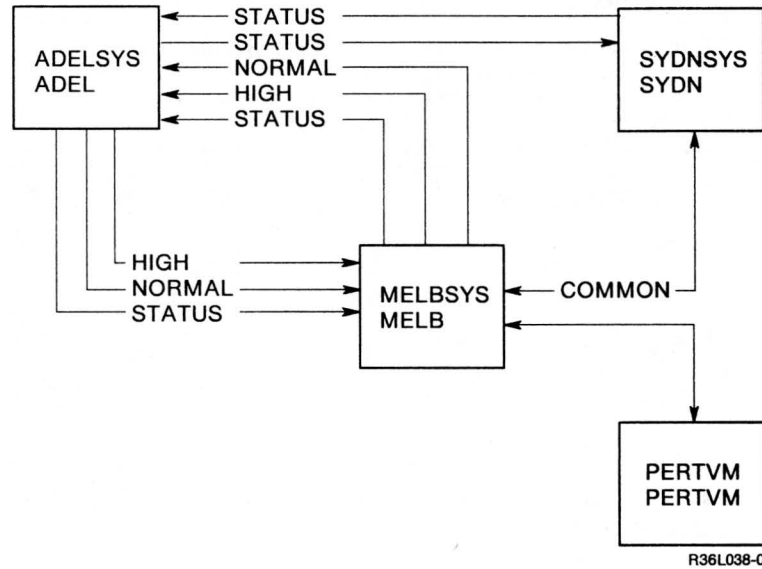

Figure 2-6. All the Communication Routes for a Network of System/36 Systems

Example 1: On the ODF/36 main menu, select option 8 (Set up or maintain ODF/36 functions) and press the Enter key.

```

COMMAND                                ODF/36                                W5
                                     Use Object Distribution Facility/36

Select one of the following:

1. Send an object
2. Work with arrived objects
3. Work with messages
4. Perform daily operations
5. Work with directory
6. Work with lists
7. Work with profiles
8. Set up or maintain ODF/36 functions

Cmd3-Previous Menu    Cmd5-Main help menu    COPR IBM Corp. 1988

Ready for option number or command

```

The ODFMNT menu appears.

```

COMMAND                                ODFMNT                                W5

                Set up or maintain Object Distribution Facility/36 functions

Select one of the following:

1. Set up ODF/36 support files and folders
2. Maintain system defaults for ODF/36
3. Set up PS/36 (SNADS) support files and folders
4. Maintain system defaults for PS/36 (SNADS)
5. Maintain PS/36 (SNADS) communication queues
6. Maintain communication routes
7. Maintain remote destinations

Cmd3-Previous menu  Cmd5-Main help menu                                COPR IBM Corp 1988

Ready for option number or command

```

On the ODFMNT menu, select option 6 (Maintain communications routes) and press the Enter key.

```

                                MAINTAIN COMMUNICATIONS ROUTES                                Top

Type an option and press Enter, or use Cmd5 to add routes
Options: 2=Change 4=Delete

OPTION  SYSTEM  QUEUE  REMOTE  SESSION
          PRIOR  LOCAT  GROUP

Cmd3=Go back  Cmd5=Add routes  Cmd7=Quit  Roll=Page

```

Press Cmd5 to add a communications route. The Add Communications Route appears.

```

ADD COMMUNICATIONS ROUTE
Type choices, press Enter.
ITEM          CHOICE          POSSIBLE CHOICES
SYSTEM. . . . . _____ Name of remote system

Via APPC or APPN communications
Priority      2                2 is for normal priority mail
Remote location. . . _____ as defined using CNFIGICF
Session group . . . _____ as defined using CNFIGICF
Priority      1                1 is for high priority mail
Remote location. . . _____
Session group . . . _____
Priority      0                0 is for status information
Remote location. . . _____
Session group . . . _____

Via BSC/EL communications or
via BSC MSRJE for PROFS bridge
Remote location. . . _____ As defined using CNFIGICF

Cmd3=Go back          Cmd7=Quit

```

To define all the routes for the Melbourne system (MELBSYS), the following would be entered.

For Adelaide:

```

ADD COMMUNICATIONS ROUTE
Type choices, press Enter.
ITEM          CHOICE          POSSIBLE CHOICES
SYSTEM. . . . . ADELSYS      Name of remote system

Via APPC or APPN communications
Priority      2                2 is for normal priority mail
Remote location. . . ADEL      as defined using CNFIGICF
Session group . . . NORMAL    as defined using CNFIGICF
Priority      1                1 is for high priority mail
Remote location. . . ADEL
Session group . . . HIGH
Priority      0                0 is for status information
Remote location. . . ADEL
Session group . . . STATUS

Via BSC/EL communications or
via BSC MSRJE for PROFS bridge
Remote location. . . _____ As defined using CNFIGICF

Cmd3=Go back          Cmd7=Quit

```

For Sydney:

```
ADD COMMUNICATIONS ROUTE
Type choices, press Enter.
ITEM          CHOICE          POSSIBLE CHOICES
SYSTEM. . . . . SYDNSYS      Name of remote system

Via APPC or APPN communications
Priority       2                2 is for normal priority mail
Remote location. . . SYDN      as defined using CNFIGICF
Session group . . . COMMON     as defined using CNFIGICF
Priority       1                1 is for high priority mail
Remote location. . . SYDN
Session group . . . COMMON
Priority       0                0 is for status information
Remote location. . . SYDN
Session group . . . COMMON

Via BSCEL communications or
via BSC MSRJE for PROFS bridge
Remote location. . . _____ As defined using CNFIGICF

Cmd3=Go back          Cmd7=Quit
```

For Perth:

```
ADD COMMUNICATIONS ROUTE
Type choices, press Enter.
ITEM          CHOICE          POSSIBLE CHOICES
SYSTEM. . . . . PERTVM      Name of remote system

Via APPC or APPN communications
Priority       2                2 is for normal priority mail
Remote location. . . _____ as defined using CNFIGICF
Session group . . . _____ as defined using CNFIGICF
Priority       1                1 is for high priority mail
Remote location. . . _____
Session group . . . _____
Priority       0                0 is for status information
Remote location. . . _____
Session group . . . _____

Via BSCEL communications or
via BSC MSRJE for PROFS bridge
Remote location. . . PERTVM     As defined using CNFIGICF

Cmd3=Go back          Cmd7=Quit
```

After you have added all of your routes, press Cmd3 to go back to the Maintain Communications Routes display.

```

                                MAINTAIN COMMUNICATIONS ROUTES                                Top
Type an option and press Enter, or use Cmd5 to add routes
Options: 2=Change 4=Delete

OPTION  SYSTEM      QUEUE  REMOTE  SESSION
        SYSTEM      PRIORITY LOCATION GROUP
-      ADELSYS      2      ADEL   NORMAL
        -          1      ADEL   HIGH
        -          0      ADEL   STATUS
-      PERTVM      PERTVM
        (NOT applicable for MSRJE)
        (NOT applicable for MSRJE)
-      SYDNSYS      2      SYDN   COMMON
        SYDNSYS      1      SYDN   COMMON
        SYDNSYS      0      SYDN   COMMON

Cmd3=Go back      Cmd5=Add routes      Cmd7=Quit      Roll=Page

```

Note: The text *NOT applicable for MSRJE* distinguishes a route for an RSCS system for Object Distribution Facility/36 from a Personal Services/36 PROFS Bridge route to VM/PROFS. The Personal Services/36 PROFS Bridge uses MSRJE to communicate with VM/PROFS.

What to Do Next: Now that you have completed your routes, you can create your queue definitions.

Setting Up Communications Queue Definitions

In this section, you determine the characteristics of the communications queues and create the queues to send objects to other systems.

Add a Communications Queue Definition

A queue is used to manage the sending of different priorities of objects between systems. A queue is a list of objects that are to be sent according to priorities and other characteristics about the queue that you define. When a user sends an object to a user on another system, an entry is placed in one of the queues for that system and waits there until it is ready to be sent. How the items in a queue are handled depends on how you define the queue. A queue definition tells Personal Services/36 (SNADS) how many entries must be in the queue (send length) before entries in the queue are sent one by one, how long to wait before an unsuccessful attempt to send an entry can be retried (retry interval), and when the queue is cleared of old or problem entries (purge interval).

The way you define your queues is primarily based on the amount of objects, communication costs, and operation of your communication lines.

Note: A queue definition is required if communicating with RSCS, however the queue is only used to enable Personal Services/36 (SNADS) to route objects from other SNADS systems to the next RSCS system. These objects are placed in the ODF folder (#ODFFLDR), and the LISTRSCS procedure should be used to work with entries on an RSCS queue. The Personal Services/36 (SNADS) queue for RSCS will never show entries on the queue. Only the name of an RSCS queue should be specified, all other parameters have no meaning.

The following is the Add Communications Queue Definition display. How to access this display is described later in this section.

```
ADD COMMUNICATIONS QUEUE DEFINITION

Type choices, press Enter.

ITEM                               POSSIBLE CHOICES
Remote Location. . . . . _____ as defined using CNFIGICF
Session group. . . . . _____ for APPC or APPN,
                                   as defined using CNFIGICF
                                   for MSRJE, BLANK

Send length. . . . . _1           to start transmission (0, 1-99)

Send while
receiving. . . . . 2             1=yes 2=no

Retry interval . . . . . _10      minutes (1-9999)

Purge interval . . . . . __0      hours (0, 1-9999)

Cmd3=Go back           Cmd7=Quit
```

Remote location, Session group pair

Take the remote location, session group pair from the routes you set up. These are your queues. You now need to define the send length, send-receive option, retry interval, and purge interval for each queue.

Priority

Take the priority for each remote location, session group pair from the routes you set up.

Send Length

Send length is the number of entries that must be in the queue before Personal Services/36 (SNADS) attempts to send the first entries in the queue. This is like filling the mail bag completely before it can be put on the truck to a city. The send length you choose depends on the priority of objects this queue handles and the characteristics of the communication lines to the remote system.

If this queue handles high priority or status information, then you may want to set the send length to a small number. For example, if the send length is one, objects are sent when they enter the queue. This minimizes the amount of delay for each object.

Note: If the send length is zero, you must manually start transmission through the ODFOPR menu.

If a queue handles normal priority, then you may want to set the send length to a large number. When objects enter the queue, they wait until the entries in the queue reach the queue length. For example, if the send length is 25, objects are sent when 25 entries are in the queue. Therefore, it may take longer to send an object. If you use leased lines, you will probably set the send length to one. If you use dial-up lines, you will probably set the send length to zero, or to a large number.

Estimate the send length for each queue, or use the default (1) supplied by IBM.

Send while receiving

This option allows objects to be sent to a remote system when the remote system starts sending objects to your system.

If the indicator is Yes, Personal Services/36 (SNADS) starts sending objects from this queue when objects are received from the other system, regardless of the send length.

You can only use this option if the queue communicates with another System/36, System/38, or AS/400. This option is useful when long distance dial-up communications lines are used because it reduces the number of phone calls, and usually reduces the line time required.

Note: If the send-receive indicator is No, then sending is governed by the send length.

Use of this option will increase the Personal Services/36 (SNADS) workload and may affect work station response times.

Decide if you will use send while receiving. You can use the default 2 (No) supplied by IBM.

Retry Interval

QUEUE ENTRIES

The retry interval is the minimum number of minutes an entry in a queue must wait after a recoverable error before Personal Services/36 (SNADS) tries to send the entry again. A recoverable error can be because of an object that is too large to go into the receiving system's storage folder. In the meantime, Personal Services/36 (SNADS) can send other objects in the queue.

QUEUES

Retry interval also applies to queues as a whole. If Personal Services/36 (SNADS) attempts to allocate a send session but APPC/APPN is not enabled, another attempt will be made after the retry interval has passed. The same is true if other "recoverable" errors occur when attempting to begin communications, such as having no lines available.

By defining a retry interval, you allow some time for the problem to clear up before Personal Services/36 (SNADS) tries again.

If you define a retry interval of zero, Personal Services/36 (SNADS) does not retry. You have to tell Personal Services/36 (SNADS) to retry sending the object. If the retry interval is zero, you should plan to check the queues regularly.

You cannot start transmission of the error entry again before the retry interval has passed.

If the retry interval has expired and no other objects enter the queue, then Personal Services/36 (SNADS) does not try this item again until another item enters the queue.

Estimate the retry interval for each queue, or use the default (10) supplied by IBM.

Purge interval

QUEUE ENTRIES

The purge interval is the minimum number of hours that Personal Services/36 (SNADS) lets problem objects sit on the queue before it purges them.

Suppose Personal Services/36 (SNADS) attempts to send an object in the queue, and the first object fails to be sent. The timer for the purge interval starts. Then every time after the object has been unsuccessfully retried, Personal Services/36 (SNADS) checks to see if the purge interval has passed. If it has, the object on the queue is purged.

The purge interval is also the minimum number of hours that Personal Services/36 (SNADS) allows entries to remain on a queue before the entire queue is purged.

If your system is an intermediate point in the SNADS network, objects are sent to your system to be forwarded to another SNADS system. Suppose your system has a line problem. Personal Services/36 (SNADS) attempts to forward the objects. Personal Services/36 (SNADS) continues to try to forward the objects until the line problem clears. If the purge interval passes and Personal Services/36 (SNADS) still cannot send the objects, it purges the queue. This intermediate point in the network sends back a status message to the sending system. If you did not have a purge interval, status information will not go back to the sending system.

For example, if the purge interval is one hour and the send length is 0, the object may sit on the queue for hours before it is retried (since the queue has to be manually started). If the retry interval is four hours, after four hours Personal Services/36 (SNADS) again tries to send the object. If the object has not successfully been transmitted, it is purged.

You can set the purge interval to zero if you plan to check the queues yourself.

Note: A purge interval of zero tells Personal Services/36 (SNADS) never to purge a distribution; you must do so manually.

When you or Personal Services/36 (SNADS) purges an object, a message is sent to the sender indicating the object was not delivered.

Estimate the purge interval for each queue, or use the default (0) supplied by IBM.

In this example, there is a Melbourne system (MELBSYS) and three other systems: one in Sydney (SYDNSYS), one in Adelaide (ADELSYS) and the other in Perth (PERTVM). The routes have already been added. The queues are set up as follows. (There are queues from Adelaide to Melbourne, Sydney to Melbourne, and Sydney to Adelaide, but these are not defined in your Personal Services/36 (SNADS) system).

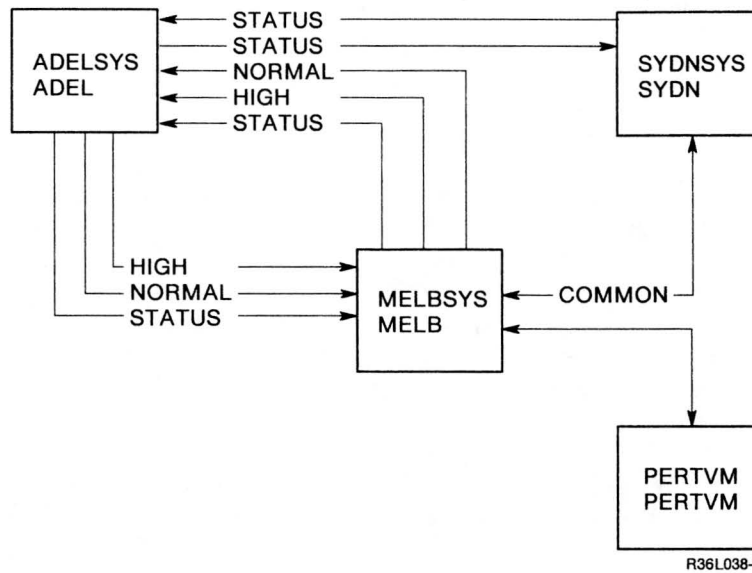

Figure 2-7. All the Communications Queues for a Network of System/36 Systems

Prompt	Value	Value	Value
Remote location	ADEL	ADEL	ADEL
Session group	NORMAL	HIGH	STATUS
Send length	0010	0000	0001
Send-receive	NO	YES	NO
Retry interval	0060	0060	0010
Purge interval	0024	0168	0000

Figure 2-8. Queue Definitions Melbourne (MELBSYS) to Adelaide (ADELSYS)

Prompt	Value
Remote location	SYDN
Session group	COMMON
Send length	0003
Send-receive	NO
Retry interval	0010
Purge interval	0008

Figure 2-9. Queue Definitions Melbourne (MELBSYS) to Sydney (SYDNSYS)

Prompt	Value
Remote location	PERTVM
Session group	
Send length	
Send-receive	
Retry interval	
Purge interval	

Figure 2-10. Queue Definitions Melbourne (MELBSYS) to Perth (PERTVM)

The remote location, session group pair on the Melbourne system (MELBSYS) going to the Sydney system (SYDNSYS) has one queue, SYDN COMMON. All three mail priorities, high, normal, and status, use SYDN COMMON. The remote location on the Melbourne system (MELBSYS) going to the Perth system (PERTVM) also has only one queue, PERTVM. Notice that no other values are defined for this queue; this queue definition is to enable Personal Services/36 (SNADS) to route objects from other SNADS system to the PERTVM RSCS system. The objects to be sent to the PERTVM RSCS system are placed in the ODF folder (#ODFFLDR). The LISTRSCS procedure can be used to work with entries on an RSCS queue.

Make sure you fill in the remote location, session group pair for each SNADS queue you defined when you set up your routes, and the queue definition.

In this example, the queues are set up as follows:

Example 1: On the ODF/36 main menu, select option 8 (Set up or maintain ODF/36 functions) and press the Enter key.

```

COMMAND                                ODF/36                                W5
                                     Use Object Distribution Facility/36

Select one of the following:

1. Send an object
2. Work with arrived objects
3. Work with messages
4. Perform daily operations
5. Work with directory
6. Work with lists
7. Work with profiles
8. Set up or maintain ODF/36 functions

Cmd3-Previous Menu      Cmd5-Main help menu      COPR IBM Corp. 1988

Ready for option number or command

```

The ODFMNT menu appears.

```

COMMAND                                ODFMNT                                W5

                Set up or maintain Object Distribution Facility/36 functions

Select one of the following:

1. Set up ODF/36 support files and folders
2. Maintain system defaults for ODF/36
3. Set up PS/36 (SNADS) support files and folders
4. Maintain system defaults for PS/36 (SNADS)
5. Maintain PS/36 (SNADS) communication queues
6. Maintain communication routes
7. Maintain remote destinations

Cmd3-Previous menu  Cmd5-Main help menu                                COPR IBM Corp 1988

Ready for option number or command

```

On the ODFMNT menu, select option 6 (Maintain communications routes) and press the Enter key.

```

                MAINTAIN COMMUNICATIONS QUEUE DEFINITIONS

Type an option and press enter, or use Cmd5 to add definitions
Options: 2=Change  4=Delete

OPTION      REMOTE    SESSION  SEND    SEND-    RETRY    PURGE
            LOCATION  GROUP   LENGTH RECEIVE INTERVAL INTERVAL

Cmd3=Go back  Cmd5=Add definitions  Cmd7=Quit  Roll=page

```

Press Cmd5 to add a communications queue definition. The Add Communications Queue Definition display appears.

```

ADD COMMUNICATIONS QUEUE DEFINITION

Type choices, press Enter.

ITEM
Remote Location. . . . . _____
Session group. . . . . _____

POSSIBLE CHOICES
as defined using CNFIGICF
for APPC or APPN,
as defined using CNFIGICF
for MSRJE, BLANK

Send length. . . . . _1          to start transmission (0, 1-99)

Send while
receiving. . . . . 2            1=yes 2=no

Retry interval . . . . . _10      minutes (1-9999)

Purge interval . . . . . __0      hours (0, 1-9999)

Cmd3=Go back          Cmd7=Quit

```

To define all communications queues for the Melbourne system (MELBSYS), the following would be entered.

For NORMAL to Adelaide:

```

ADD COMMUNICATIONS QUEUE DEFINITION

Type choices, press Enter.

ITEM
Remote Location. . . . . ADEL
Session group. . . . . NORMAL

POSSIBLE CHOICES
as defined using CNFIGICF
for APPC or APPN,
as defined using CNFIGICF
for MSRJE, BLANK

Send length. . . . . 10          to start transmission (0, 1-99)

Send while
receiving. . . . . 2            1=yes 2=no

Retry interval . . . . . 0060     minutes (1-9999)

Purge interval . . . . . 0024     hours (0, 1-9999)

Cmd3=Go back          Cmd7=Quit

```

For HIGH to Adelaide:

```
ADD COMMUNICATIONS QUEUE DEFINITION

Type choices, press Enter.

ITEM
Remote Location. . . . . ADEL
Session group. . . . . HIGH

Send length. . . . . 00

Send while
receiving. . . . . 1

Retry interval . . . . . 0060

Purge interval . . . . . 0168

Cmd3=Go back          Cmd7=Quit

POSSIBLE CHOICES
as defined using CNFIGICF
for APPC or APPN,
as defined using CNFIGICF
for MSRJE, BLANK

to start transmission (0, 1-99)

1=yes 2=no

minutes (1-9999)

hours (0, 1-9999)
```

For STATUS to Adelaide:

```
ADD COMMUNICATIONS QUEUE DEFINITION

Type choices, press Enter.

ITEM
Remote Location. . . . . ADEL
Session group. . . . . STATUS

Send length. . . . . 01

Send while
receiving. . . . . 2

Retry interval . . . . . 0010

Purge interval . . . . . 0000

Cmd3=Go back          Cmd7=Quit

POSSIBLE CHOICES
as defined using CNFIGICF
for APPC or APPN,
as defined using CNFIGICF
for MSRJE, BLANK

to start transmission (0, 1-99)

1=yes 2=no

minutes (1-9999)

hours (0, 1-9999)
```

For COMMON to Sydney:

```
ADD COMMUNICATIONS QUEUE DEFINITION

Type choices, press Enter.

ITEM
Remote Location. . . . . SYDN
  Session group. . . . . COMMON

POSSIBLE CHOICES
as defined using CNFIGICF
for APPC or APPN,
  as defined using CNFIGICF
for MSRJE, BLANK

Send length. . . . . 03      to start transmission (0, 1-99)

Send while
receiving. . . . . 2        1=yes 2=no

Retry interval . . . . . 0010  minutes (1-9999)

Purge interval . . . . . 0008  hours (0, 1-9999)

Cmd3=Go back      Cmd7=Quit
```

For Perth:

```
ADD COMMUNICATIONS QUEUE DEFINITION

Type choices, press Enter.

ITEM
Remote Location. . . . . PERTVM
  Session group. . . . . _____

POSSIBLE CHOICES
as defined using CNFIGICF
for APPC or APPN,
  as defined using CNFIGICF
for MSRJE, BLANK

Send length. . . . . 1      to start transmission (0, 1-99)

Send while
receiving. . . . . 2        1=yes 2=no

Retry interval . . . . . 10   minutes (1-9999)

Purge interval . . . . . 0    hours (0, 1-9999)

Cmd3=Go back      Cmd7=Quit
```

Note: Only the remote location is entered for an RSCS queue definition. Let all the other values default, they are not used.

After you have added all of your communications queue definitions, press Cmd3 to go back to the Maintain Communications Queue Definitions display.

MAINTAIN COMMUNICATIONS QUEUE DEFINITIONS

Type an option and press enter, or use Cmd5 to add definitions
Options: 2=Change 4=Delete

OPTION	REMOTE LOCATION	SESSION GROUP	SEND LENGTH	SEND-RECEIVE	RETRY INTERVAL	PURGE INTERVAL
-	ADEL	HIGH	0010	NO	0060	0024
-	ADEL	NORMAL	0000	YES	0060	0168
-	ADEL	STATUS	0001	NO	0010	0000
-	PERTVM		0010	NO	0010	0000
-	SYDN	COMMON	0003	NO	0010	0008

Cmd3=Go back

Cmd5=Add definitions

Cmd7=Quit

Roll=page

What to do next: Now that you have completed your queue definitions, you can add your remote directory entries.

Defining Remote Directory Entries

Note: Personal Services/36 changed the way certain information is entered in the directory. In previous releases, a special type of directory entry containing an asterisk (*) in the user ID could be entered. The functions provided by this type of entry are now controlled with Remote Destination entries. If you have directory entries with * in the user ID, they are automatically converted when you install the latest release.

Setting Up Directory Entries

In this section, you determine the directory entries you need to send objects to remote locations.

Add Remote Destinations

A remote destination allows you to send objects to a remote location without specifying each remote user ID at your local system. This eliminates the need for each user at a remote system to have an entry in your directory. You can choose an address that is different from the system name; however, if there are S/370 systems in your network, then the address must be the same as the system name for compatibility with S/370 RSCS networking.

You can only have one address per system using Object Distribution Facility/36. There can be many user IDs.

The following is the Add Remote Destination display. How to access this display is described later in this section.

```

                                ADD REMOTE DESTINATION
Type choices, press Enter.
ITEM                            CHOICE    POSSIBLE CHOICES
Address . . . . . _____  Address for distribution or
                                library services
System . . . . . _____
Description . . . . . _____
VM PROFS . . . . . _          1=Yes 2=No
  Distribution manager . . . _____  PROFS distribution manager name
Library services . . . . . _      1=Yes 2=No

Cmd3=Go back      Cmd7=Quit
```

Address

Every user has an address. The address, in combination with the user ID helps to identify what system the user is on for distributing objects. The user ID plus the address form the complete address used to distribute objects throughout the network.

System

This is the name of the remote system to which you want to send objects. When objects are sent, the user enters a user ID and an address. Personal Services/36 (SNADS) checks the directory for this user ID and address combination. Personal Services/36 (SNADS) then identifies the remote system to which you want the object to go.

Description

This is a brief description of the remote destination entry you are adding. This description can be no longer than 35 characters.

VM PROFS

This field is not used by Object Distribution Facility/36 and must be set to 2 (No).

Distribution manager

This field is not used by Object Distribution Facility/36 and must not be specified.

Library services

This field is not used by Object Distribution Facility/36.

For example, suppose you have 50 users at the system in Sydney (SYDNSYS), 50 users at the system in Adelaide (ADELSYS), and 50 users at the system in Perth (PERTVM). Instead of setting up 150 directory entries, you can simply set up three remote destination entries as follows:

Address	System	PROFS	Distribution Mgr
SYDNSYS	SYDNSYS	No	
ADELSYS	ADELSYS	No	
PERTVM	PERTVM	No	

Note: A user ID is not required. You must supply an address and a system name for each remote destination entry.

A remote destination entry saves maintenance on large directories. If you are planning a small System/36 network, you can set up a directory entry for each user of a remote system. To get a complete list of users, contact the administrators at all the remote systems.

In practice, you should create remote destination entries for all remote systems, and then add directory entries for those remote users that users on your System/36 contact frequently.

Example 1: On the ODF/36 main menu, select option 8 (Set up or maintain ODF/36 functions) and press the Enter key.

COMMAND

ODF/36

W5

Use Object Distribution Facility/36

Select one of the following:

1. Send an object
2. Work with arrived objects
3. Work with messages
4. Perform daily operations
5. Work with directory
6. Work with lists
7. Work with profiles
8. Set up or maintain ODF/36 functions

Cmd3-Previous Menu

Cmd5-Main help menu

COPR IBM Corp. 1988

Ready for option number or command

The ODFMNT menu appears.

COMMAND

ODFMNT

W5

Set up or maintain Object Distribution Facility/36 functions

Select one of the following:

1. Set up ODF/36 support files and folders
2. Maintain system defaults for ODF/36
3. Set up PS/36 (SNADS) support files and folders
4. Maintain system defaults for PS/36 (SNADS)
5. Maintain PS/36 (SNADS) communication queues
6. Maintain communication routes
7. Maintain remote destinations

Cmd3-Previous menu

Cmd5-Main help menu

COPR IBM Corp 1988

Ready for option number or command

On the ODFMNT menu, select option 7 (Maintain remote destinations) and press the Enter key.

MAINTAIN REMOTE DESTINATIONS

To reposition list, type value and press Enter.
 Position list to . . . _____ Starting character(s) of ADDRESS

LIST OF REMOTE DESTINATIONS

Type an option and press Enter, or use Cmd5 to add remote destinations.
 Options: 2=Change 4=Delete

OPTION	ADDRESS	SYSTEM	DESCRIPTION	VM PROFS	LIBRARY SERVICES

Cmd3=Go back Cmd5=Add remote destination
 Cmd7=Quit Cmd8=Reset Roll=Page

Press Cmd5 to add a remote destination. The Add Remote Destination display appears.

ADD REMOTE DESTINATION

Type choices, press Enter.

ITEM	CHOICE	POSSIBLE CHOICES
Address	_____	Address for distribution or library services
System	_____	
Description	_____	
VM PROFS	_	1=Yes 2=No
Distribution manager . . .	_____	PROFS distribution manager name
Library services	_	1=Yes 2=No

Cmd3=Go back Cmd7=Quit

To define the remote destinations for the Melbourne system (MELBSYS) the following would be entered.

For Sydney:

```
ADD REMOTE DESTINATION

Type choices, press Enter.

ITEM                CHOICE    POSSIBLE CHOICES
Address . . . . . SYDNSYS    Address for distribution or
                        library services
System . . . . . SYDNSYS
Description . . . . . All users at Sydney
VM PROFS . . . . . 2          1=Yes 2=No
  Distribution manager . . . _____ PROFS distribution manager name
Library services . . . . . 2          1=Yes 2=No

Cmd3=Go back      Cmd7=Quit
```

For Adelaide:

```
ADD REMOTE DESTINATION

Type choices, press Enter.

ITEM                CHOICE    POSSIBLE CHOICES
Address . . . . . ADELSYS    Address for distribution or
                        library services
System . . . . . ADELSYS
Description . . . . . All users at Adelaide
VM PROFS . . . . . 2          1=Yes 2=No
  Distribution manager . . . _____ PROFS distribution manager name
Library services . . . . . 2          1=Yes 2=No

Cmd3=Go back      Cmd7=Quit
```

For Perth:

```

                                ADD REMOTE DESTINATION
Type choices, press Enter.
ITEM                            CHOICE    POSSIBLE CHOICES
Address . . . . . PERTVM        Address for distribution or
                                library services
System . . . . . PERTVM
Description . . . . . All users at Perth
VM PROFS . . . . . 2            1=Yes 2=No
  Distribution manager . . . . . _____ PROFS distribution manager name
Library services . . . . . 2      1=Yes 2=No

Cmd3=Go back      Cmd7=Quit
```

Add a Directory Entry for a Remote User

The directory entry for a user at a remote system consists of three major parts. These are user ID, address, and system.

User ID

If you choose to set up a directory entry for every user at a remote system then you can call the administrators at the other systems for a list of user IDs on their system. Some user IDs may be the same as on your system, but this is not a cause for concern as the address makes them unique.

Address

Every user has an address. The address in combination with user ID helps to identify what system the user is on for distributing objects. The user ID plus the address make up the complete address used to distribute objects throughout the network.

System Name

This is the name of the remote system to which you want to send objects. When sending an object, the user enters a user ID and an address. Personal Services/36 (SNADS) checks the directory for this user ID and address combination. Personal Services/36 (SNADS) then identifies the remote system to which you want the objects to go. Usually, you should leave this field blank on remote user entries in the directory. Personal Services/36 (SNADS) then uses the remote destination entries to find out to which system to send the objects. The reason for leaving the system name blank is to save maintenance work; if all the users in an address are moved to another system, then you need to change only the remote destination entry. Otherwise, you might have to change many directory entries. You should only use this field for a user who moves to a system, where the address does not have to change.

When you send an object to another system, Personal Services/36 (SNADS) checks the directory entry and identifies the remote system using the user ID and address. The user ID and address combination identify the user when the object reaches the other system.

Example 1

```

COMMAND                                ODF/36                                W5

                                Use Object Distribution Facility/36

Select one of the following:

1. Send an object
2. Work with arrived objects
3. Work with messages
4. Perform daily operations
5. Work with directory
6. Work with lists
7. Work with profiles
8. Set up or maintain ODF/36 functions

Cmd3-Previous Menu    Cmd5-Main help menu                                COPR IBM Corp. 1988

Ready for option number or command

```

On the ODF/36 main menu, select option 5 (Work with directory) and press the Enter key.

The View or Maintain Names Sorted by User ID display appears.

```

Directory          VIEW OR MAINTAIN NAMES SORTED BY USER ID
To reposition list, type value and press Enter
Position list to . . . _____ Starting character(s) of USER ID

                                LIST OF DIRECTORY ENTRIES                                Top
Type an option and press ENTER, or use Cmd5 to add entries
Options: 2=Change details 4=Delete entry 5=View details

OPTION USER ID  ADDRESS  NAME                                AREA
                                                CODE  NUMBER

Cmd3=Go back    Cmd5=Add entries    Cmd7=Quit    Roll=Page

```

Press Cmd5 to add entries to the directory.

Enter the user ID, address, mailing name, name on alphabetic list, and system name for each remote user.

```

                                ADD DIRECTORY ENTRY
Type choices, press Enter
ITEM                               CHOICE    POSSIBLE CHOICES
User ID . . . . .                JOHN
Address . . . . .                SYDNSYS    For document distribution
Mailing Name . . . . .          JOHN CITIZEN
Address line 1 . . . . .        _____
Address line 2 . . . . .        _____
Address line 3 . . . . .        _____
Address line 4 . . . . .        _____
Name on alphabetic list . . . . . JOHN CITIZEN
Company employee . . . . .      2          1 = Yes 2 = No
Use PS/36 mail functions . . . . 2          1 = Yes 2 = No
Telephone
Country . . . . .                _____
Area or city code . . . . .     _____
Telephone number . . . . .      _____
Extension . . . . .             _____
Alternate number . . . . .      _____
Location . . . . .              _____
Department . . . . .            _____
System name . . . . .           SYDNSYS
Cmd3=Go back      Cmd7=Quit

```

For this example, enter 2 (No) for the prompts *Company employee* and *Use PS/36 mail functions*, since users at remote systems cannot use these features on your system.

When you have completed adding your directory entries, press Cmd3 to go back to the View or Maintain Names Sorted by User ID display.

```

Directory          VIEW OR MAINTAIN NAMES SORTED BY USER ID
To reposition list, type value and press Enter
Position list to . . . _____ Starting character(s) of USER ID

                                LIST OF DIRECTORY ENTRIES
Type an option and press ENTER, or use Cmd5 to add entries
Options: 2=Change details 4=Delete entry 5=View details
                                Top
OPTION USER ID  ADDRESS  NAME          AREA
                CODE    NUMBER
_   JOHN      SYDNSYS  JOHN CITIZEN

Cmd3=Go back      Cmd5=Add entries      Cmd7=Quit      Roll=Page

```

Chapter 3. Running ODF/36

Before using the information in this chapter to run ODF/36, the ODF/36 PRPQ must be installed on your System/36. See Chapter 2, "Setting Up ODF/36."

The following information is given for procedures described in this chapter:

- The function of the procedure.
- The syntax format of the procedure command that calls the procedure. For a description of the rules used for syntax formats, see the *IBM System/36 System Reference Manual*.
- Descriptions of the parameters used in the procedure command.
- One or more examples of how to use the procedure and how to enter the procedure command or statements to run the procedure.

Sending Objects Interactively

Use the ODF procedure to display the ODF/36 main menu.

```
COMMAND                                ODF/36                                W5

                                Use Object Distribution Facility/36

Select one of the following:

1. Send an object
2. Work with arrived objects
3. Work with messages
4. Perform daily operations
5. Work with directory
6. Work with lists
7. Work with profiles
8. Set up or maintain ODF/36 functions

Cmd3-Previous Menu    Cmd5-Main help menu                                COPR IBM Corp. 1988

Ready for option number or command
```

Figure 3-1. ODF/36 Main Menu

From this display the operator may choose options 1 through 8. Help for an option is available by entering the option number and pressing the HELP key.

Options 1, 2, 3, and 7 are described in this chapter.

On the ODF/36 main menu, select option 1 (Send an object) and press Enter.

The Send Object Menu appears.

```
COMMAND                                ODFSND                                W5

                                Send an Object

Select one of the following:

1. Send a file
2. Send a folder
3. Send a job stream
4. Send a library member
5. Send a spooled print file

Cmd3-Previous menu    Cmd5-Main help menu                                COPR IBM Corp. 1988

Ready for option number or command
```

Figure 3-2. Send Object Menu

From this display the operator may choose options 1 through 5. Help for an option is available by entering the option number and pressing the Help key.

Selecting options 1 through 5 on the Send Object Menu shown in Figure 3-2 on page 3-2 will cause the following ODF/36 send prompts to be displayed.

Option 1 (Send a file) runs the SENDFILE procedure.

SEND FILE OR GROUP OF FILES THROUGH NETWORK		
Type choices, press Enter.		
ITEM	CHOICE	POSSIBLE CHOICES
File name	_____	Name, ALL
If ALL, enter group name . .	_____	
Creation date	_____	
Format	S36FMT	S36FMT, DATA, PUNCH
User	_____	
Address	_____	
Priority	50	1-99
RSCS distribution code	_____	
RSCS class	A	A-Z
Acknowledgment	NOACK	NOACK, ACK

Cmd3=Go back Cmd5=Add user list Cmd7=End

COPR IBM Corp. 1988

Figure 3-3. Prompt for Sending Files

Sending Objects Interactively

Option 2 (Send a folder) runs the SENDFLDR procedure.

```
SEND FOLDER THROUGH NETWORK
Type choices, press Enter.
ITEM          CHOICE    POSSIBLE CHOICES
Folder name . . . . . _____
User . . . . . _____
Address . . . . . _____
Priority . . . . . 50      1-99
RSCS distribution code . . . . . _____
RSCS class . . . . . A      A-Z
Acknowledgment . . . . . NOACK  NOACK, ACK

Cmd3=Go back          Cmd5=Add user list      Cmd7=End
COPR IBM Copr. 1988
```

Figure 3-4. Prompt for Sending a Folder

Option 3 (Send a job stream) runs the SENDJOB procedure.

```
SEND JOB STREAM THROUGH NETWORK
Type choices, press Enter.
ITEM          CHOICE    POSSIBLE CHOICES
Member name . . . . . _____
Member type . . . . . SOURCE  SOURCE, PROC
Library name . . . . . #LIBRARY
Format . . . . . DATA     DATA, PUNCH
User . . . . . _____
Address . . . . . _____
Priority . . . . . 50      1-99
RSCS distribution code . . . . . _____
RSCS class . . . . . A      A-Z
Acknowledgment . . . . . NOACK  NOACK, ACK

Cmd3=Go back          Cmd5=Add user list      Cmd7=End
COPR IBM Corp. 1988
```

Figure 3-5. Prompt for Sending a Job Stream

Option 4 (Send library member(s)) runs the SENDLIBR procedure.

```

SEND LIBRARY MEMBERS THROUGH NETWORK
Type choices, press Enter.
ITEM          CHOICE    POSSIBLE CHOICES
Member name . . . . . _____ Name, partial name, ALL
If partial name, enter ALL. .
Member type . . . . . SOURCE   SOURCE, LOAD, PROC, LIBRARY,
                                     SUBR, PTF
Library . . . . . #LIBRARY
Format . . . . . S36FMT   S36FMT, DATA, PUNCH
User . . . . . _____
Address . . . . . _____
Priority . . . . . 50       1-99
RSCS distribution code . . . .
RSCS class . . . . . A       A-Z
Acknowledgment . . . . . NOACK   NOACK, ACK

Cmd3=Go back      Cmd5=Add user list      Cmd7=End
COPR IBM Corp.1988
    
```

Figure 3-6. Prompt for Sending Library Members

Option 5 (Send a spooled print file) runs the SENDPRT procedure.

```

SEND SPOOLED PRINT FILES THROUGH NETWORK
Type choices, press Enter.
ITEM          CHOICE    POSSIBLE CHOICES
Entries . . . . . _____ ALL, Fxxxx, SYSTEM, spool id
Cancel or release . . . . . _____ CANCEL, RELEASE
User . . . . . _____
Address . . . . . _____
Priority . . . . . 50       1-99
RSCS distribution code . . . .
RSCS class . . . . . A       A-Z
RSCS tag . . . . . _____
Acknowledgment . . . . . NOACK   NOACK, ACK

Cmd3=Go back      Cmd5=Add user list      Cmd7=End
COPR IBM Corp. 1988
    
```

Figure 3-7. Prompt for Sending Spooled Print Files

The ODF/36 send prompts show the parameters that can be entered for each type of object to be sent. Required parameters are highlighted.

Objects can be sent to one or more users. To send objects to more than one user, a distribution list name can be used. Additional users can also be entered on the Add User List display shown in Figure 3-8.

Sending Objects Interactively

The following keys can be used on the ODF/36 send prompts shown in the displays from Figure 3-3 through Figure 3-7:

Enter key processes the input from the display. If there are any syntax errors, they appear in reverse image on the display and a message describing the error appears at the bottom of the display. If there are no errors, the send request is processed.

If additional user ID/address pairs had been entered on the Add User List display, then the Add User List display appears with the previously entered user ID/address pairs. This allows changes to be made before the object is sent.

After the send request is processed, the send prompt will be displayed again. All previously entered parameters, including any entered on the Add User List display will be preserved.

Cmd 3 = Go back ignores any changes you have made and returns you to the previous display.

Cmd 5 = Add user list processes the input from the display. If there are any syntax errors, they appear in reverse image and a message describing the error appears at the bottom of the display. If there are no errors, the Add User List display shown in Figure 3-8 is presented.

If a user ID and address was entered on any of the send prompt displays, it is copied to the Add User List display as the first entry.

If additional user ID/address pairs had been entered on the Add User List display, then the Add User List display appears with the the previously entered user ID/address pairs. This allows changes to be made before the object is sent.

After the Enter key is pressed on the Add User List display and the send request is processed, the send prompt is displayed again. All previously entered parameters, including any entered on the Add User List display are preserved.

Cmd 7 = End ignores any changes you have made and returns you to the previous menu.

ADD USER LIST					
Type User IDs and addresses, press ENTER to send.					
User ID	Address	User ID	Address	User Id	Address
_____	_____	_____	_____	_____	_____
_____	_____	_____	_____	_____	_____
_____	_____	_____	_____	_____	_____
_____	_____	_____	_____	_____	_____
_____	_____	_____	_____	_____	_____

Cmd3=Go back Cmd7=End

Figure 3-8. ODF/36 Add User List Display

On the Add User List display shown in Figure 3-8, up to a maximum of 15 user ID/address pairs can be entered. This display is used any time you want to send objects to more than one user and a distribution list for the users does not exist.

The following keys can be used on the Add User List display:

Enter key processes the input from the display. If there are any syntax errors, they appear in reverse image and a message describing the error appears at the bottom of the display. If there are no errors, the send request is processed.

After the send request is processed, the send prompt is displayed again. All previously entered parameters, including any entered on the Add User List display are preserved.

Cmd 3 = Go back ignores any changes you have made and returns you to the previous display.

Cmd 7 = End ignores any changes you have made and returns you to the previous menu.

The information entered on the Add User List display is kept if you don't leave the ODF/36 send function by pressing Cmd 3 or Cmd 7 on any of the send prompt displays or pressing Cmd 7 on the Add User List display.

Example 1

To send file FILE1 to user JEFF MELBS36B, the SENDFILE prompt could be completed as shown in Figure 3-9.

SEND FILE OR GROUP OF FILES THROUGH NETWORK		
Type choices, press Enter.		
ITEM	CHOICE	POSSIBLE CHOICES
File name	FILE1	Name, ALL
If ALL, enter group name . .	_____	
Creation date	_____	
Format	S36FMT	S36FMT, DATA, PUNCH
User	JEFF	
Address	MELBS36B	
Priority	50	1-99
RSCS distribution code	_____	
RSCS class	A	A-Z
Acknowledgment	NOACK	NOACK, ACK

Cmd3=Go back Cmd5=Add user list Cmd7=End

COPR IBM Corp. 1988

Figure 3-9. Interactive Send Example - Display 1

If after typing the information shown in Figure 3-9, it is required that the file also be sent to users PAUL MELBS36B and BECKY MELBVMA, then Cmd5 = Add user list can be used.

By pressing Cmd5 rather than the Enter key, the Add User List display will appear with JEFF MELBS36B as the first entry on the display as shown in Figure 3-10.

Sending Objects Interactively

```
ADD USER LIST

Type User IDs and addresses, press ENTER to send.

User ID  Address  User ID  Address  User Id  Address
JEFF     MELBS36B

Cmd3=Go back  Cmd7=End
```

Figure 3-10. Interactive Send Example - Display 2

PAUL MELBS36B and BECKY MELBVMA can then be added as shown in Figure 3-11. File FILE1 will now be sent to all 3 users.

```
ADD USER LIST

Type User IDs and addresses, press ENTER to send.

User ID  Address  User ID  Address  User Id  Address
JEFF     MELBS36B  PAUL    MELBS36B  BECKY   MELBVMA

Cmd3=Go back  Cmd7=End
```

Figure 3-11. Interactive Send Example - Display 3

After the processing for the send request shown in Figure 3-11 has completed, the SENDFILE prompt is redisplayed and a message appears at the bottom of the display confirming that the send request has been processed.

Note: The user ID and address fields will be blank.

To send FILE2 to the same users, simply type FILE2 as the file name on the display shown in Figure 3-12.

```

SEND FILE OR GROUP OF FILES THROUGH NETWORK
Type choices, press Enter.
ITEM          CHOICE    POSSIBLE CHOICES
File name . . . . . FILE2     Name, ALL
If ALL, enter group name . . . . .
Creation date . . . . .
Format . . . . . S36FMT   S36FMT, DATA, PUNCH
User . . . . .
Address . . . . .
Priority . . . . . 50         1-99
RSCS distribution code . . . . .
RSCS class . . . . . A           A-Z
Acknowledgment . . . . . NOACK      NOACK, ACK

Cmd3=Go back      Cmd5=Add user list      Cmd7=End
COPR IBM Corp. 1988
** Send request has been processed      ODF-9742
    
```

Figure 3-12. Interactive Send Example - Display 4

Pressing Enter or Cmd5 from the display shown in Figure 3-12, results in the Add User List display shown in Figure 3-13 being redisplayed with the previously entered list of users.

If required, changes can be made on this display, including additions or deletions; however, the information for JEFF MELBS36B, PAUL MELBS36B, and BECKY MELBVMA does not need to be retyped.

If Cmd3 is pressed, the user list is ignored and the previous display, as shown in Figure 3-12, is redisplayed.

```

ADD USER LIST

Type User IDs and addresses, press ENTER to send.

User ID  Address  User ID  Address  User Id  Address
JEFF     MELBS36B  PAUL     MELBS36B  BECKY    MELBVMA

Cmd3=Go back      Cmd7=End
    
```

Figure 3-13. Interactive Send Example - Display 5

ODF/36 Procedures

This reference can be used to quickly locate the procedure for the function you want.

Procedure Name	Function Performed	Page
LISTOBJ Procedure	Lists the objects that have arrived for a user	3-12
LISTRSCS procedure	Lists the objects queued on an RSCS link	3-30
MSG Control Command	Sending and displaying messages	3-36
ODFCANCL Procedure	Stops the ODF background tasks	3-39
ODFDFLT Procedure	Changes the ODF system defaults	3-40
ODFINSTL Procedure	Initializes files, folders and default values	3-40
ODFIPL Procedure	Prepares ODF environment for folders and communications	3-41
ODFLOAD Procedure	Copies the ODF/36 PRPQ onto the system	3-42
ODFPROF Procedure	Create, update, delete ODF user profiles	3-43
ODFSTART Procedure	Starts the ODF background tasks	3-46
OFCCANCL Procedure	Stops the Personal Services/36 (SNADS) background tasks	3-46
OFCCOMM Procedure	Maintain communications definitions	3-47
OFCTRL Procedure	Controls Personal Services/36 (SNADS) background tasks and distributions	3-48
OFCDFLT Procedure	Changes the default values used by Personal Services/36 (SNADS)	3-49
OFCDIR Procedure	Work with the directory	3-50
OFCDIR Procedure	Work with lists	3-51
OFCDIR Procedure	Initializes Personal Services/36 (SNADS) files, folders and default values	3-51
OFCDIR Procedure	Maintain communications definitions	3-52
OFCDIR Procedure	Controls Personal Services/36 (SNADS) communications queues	3-53
OFCDIR Procedure	Batch interface to receive objects into a file	3-55
OFCDIR Procedure	Batch interface to receive objects into a folder	3-56
OFCDIR Procedure	Batch interface to receive objects into a library	3-57
OFCDIR Procedure	Batch interface to print and delete objects	3-58
OFCDIR Procedure	Send a file or group of files	3-59
OFCDIR Procedure	Send a folder	3-63

Figure 3-14 (Part 1 of 2). ODF/36 Procedures Quick Reference

Procedure Name	Function Performed	Page
SENDJOB Procedure	Send a job streams	3-65
SENDLIBR Procedure	Send library members	3-67
SENDPRT Procedure	Send spooled print file(s)	3-70
STOPRSCS Procedure	Stop RSCS communications links	3-73
STRTRSCS Procedure	Start an RSCS communications link	3-74

Figure 3-14 (Part 2 of 2). ODF/36 Procedures Quick Reference

Note: All OFC procedures are Personal Services/36 (SNADS) procedures. Only those Personal Services/36 (SNADS) procedures and parameters that are used by Object Distribution Facility/36 are described in this manual.

See "Object Distribution Facility/36 and SNADS" on page 1-3 for information on the relationship between Object Distribution Facility/36 and Personal Services/36 (SNADS). See the *Administering Personal Services/36 in the Office* manual for information on Personal Services/36.

LISTOBJ Procedure

This procedure processes a list of objects that have arrived for a user.

```
LISTOBJ [CRT  
file name], [user id]
```

R36L014-1

If no parameters are specified, CRT is assumed and the list of arrived objects is displayed.

CRT specifies that the list of arrived objects is displayed. Objects can be received, deleted, viewed, and printed.

file name specifies the name of a disk file to be created. The file will contain one record for each arrived object. If a file of the same name already exists, an error message is issued. See "Outputting the List of Arrived Objects to a Disk File" on page 3-29 for more information on this parameter.

user ID specifies which user's list of arrived objects is processed.

Note: A security officer can list objects for any users except another security officer or a master security officer. A master security officer can list objects for any user.

Figure 3-15 shows a Work With Arrived Objects display.

WORK WITH ARRIVED OBJECTS										Top
Select object(s) using options listed, press Enter.										
1=Receive into file			2=Receive into folder			3=Receive into library				
4=Delete			5-View			6=Print and delete				
OPT	OBJECT NAME	TYPE	NUM	RECORDS	USER ID	/ADDRESS	DATE	TIME		
-	PAYROL.1	M871116	FILE	0080	0000225	JERRY	MELBS36A	041088	102220	
-	PAYROL.2	M871113	AIFILE	0083	0000106	JERRY	MELBS36A	041088	102238	
-	PAYROL.3	M880106	FILE	0087	0000839	JERRY	MELBS36A	041088	102329	
-	PAYLIB	PAY01	LIBR	0095	0002415	JERRY	MELBS36A	041088	103054	
-	ODFADMIN	NOTE	DATA	0167	0000092	PAUL	ROCHVMA	061088	225809	
-	#DUMP.10	M881006	DUMP	0188	0002354	JEFF	MELBS36B	121088	172526	
-	#TRACE00	M881006	TRACE	0189	0001537	JEFF	MELBS36B	121088	172925	
-	SYSLIB	PRTINV	JOB	0192	0000125	BECKY	COLL36	121088	173227	
-	QSYSPRT	*PRTF	PRINT	0216	0000357	CARL	MELB400A	151088	091308	
-	TXTJDELU	FOLDER	FLDR	0250	0012070	JEFF	MELBS36B	181088	081553	
-	MYPCDISK	M871104	VDISK	0254	0001422	BECKY	COLL36	181088	081630	
-	SAVJLIB	*SAVF	SVF400	0257	0006936	CARL	MELB400A	181088	083626	
-	CUSTCDT	M871218	FILE	0258	0000522	BECKY	COLL36	181088	083922	
-	#LIBRARY	#CCMQ	PTF	0271	0004789	JEFF	MELBS36B	181088	132924	
Cmd1=Subset list			Cmd2=Select User			Cmd3=Go Back		Cmd5=Refresh		
Cmd7=End			Cmd8=Reset			Roll=Page				

Figure 3-15. List of Arrived Objects

From this display, by selecting the appropriate option as shown at the top of the display, you can choose to view an object on your display, delete the object, print a spooled print file, or receive an object into a file, folder, or library. The desired option number is typed in the option column.

The following explains the column headings on the Work With Arrived Objects display:

Column Heading	Description
OPT	Input option
OBJECT NAME	Name of the arrived object. Each object has a two-part name.
TYPE	Object type. See Figure 3-19 on page 3-16 for a description of the various object types.
NUM	Sequence number. A 4-digit number assigned by ODF/36 to assist in uniquely identifying arrived objects.
RECORDS	Number of records that comprise the object.
USER ID	User the object was sent from.
ADDRESS	Address the object was sent from.
DATE	Date the object arrived. Note: The date is the system date and is in the system date format at the time the object arrived.
TIME	Time the object arrived.

The list of arrived objects may be larger than one display (14 entries); the Page Up and Page Down keys can be used to page through the list of arrived objects.

The top right-hand corner of the arrived objects display will indicate the following:

- All** The entire list of arrived objects for a user is displayed. There are 14 objects or less.
- Bottom** This is the last display of arrived objects for a user. There are more than 14 objects in the list. The Page Up key can be used to page upward through the list of arrived objects.
- More** This display is between the first and last page of arrived objects for a user. There are more than 28 objects in the list. The Page Up and Page Down keys can be used to page through the list of arrived objects.
- Top** This is the first display of the list of arrived objects for a user. There are more than 14 objects in the list. The Page Down key can be used to page downward through the list of arrived objects.

Options can be selected on multiple displays that constitute your total list of arrived objects, and will be held pending until the Enter key is pressed. At this time, all pending options will be processed in the order they appear in the arrived objects list.

Figure 3-16 shows how the LISTOBJ function logically works.

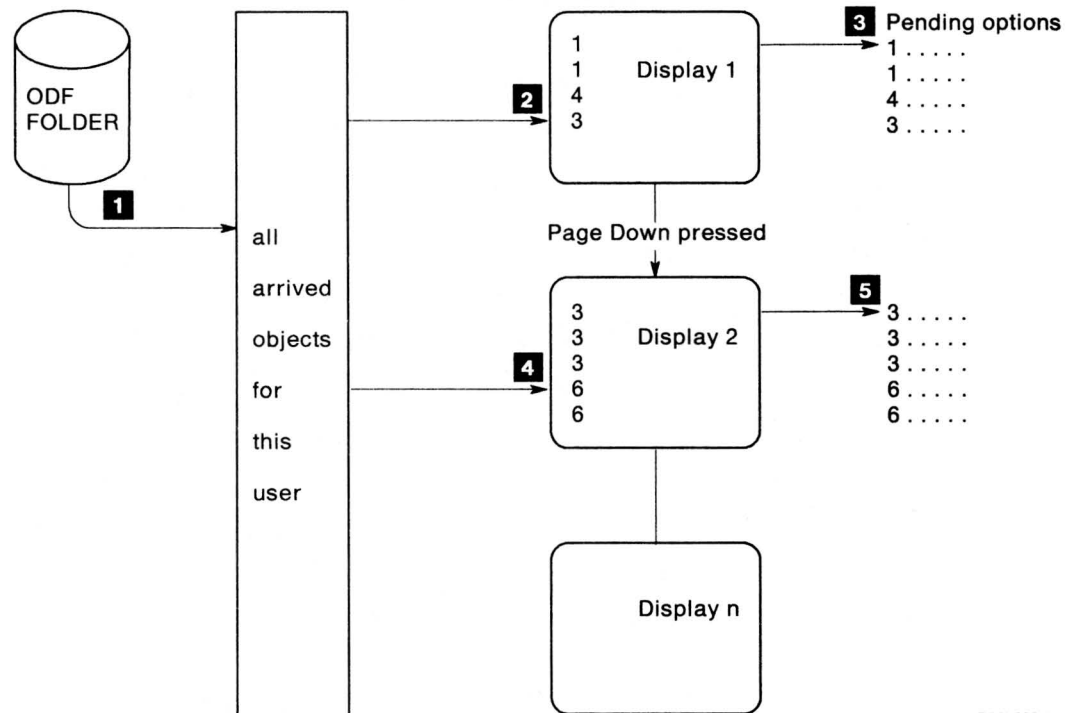

R36L022-2

Figure 3-16. How the LISTOBJ function logically works. **1** The ODF folder is searched for all arrived objects for the requesting user, and a system managed list is created. This list is now independent of the ODF folder. That is, it is a static list.

2 The first 14 entries of the list are displayed to the user as arrived objects display 1. The list position is *Top*.

3 The user selects 4 options on display 1 of arrived objects and uses the Page Down key to page to display 2 of arrived objects. At the time the page down is performed, the 4 selected options and the objects they apply to are held pending.

4 The next 14 objects in the list are displayed to the user as arrived objects display 2. The list position is *More*.

5 From display 2 of arrived objects the user selects 5 options and uses the Page Down key to page downward through the list of arrived objects. At the time the page down is performed, the 5 selected options and the objects they apply to are held pending.

There can be many displays constituting the total list of arrived objects. When the Enter key is pressed, the pending options will be processed in the order they appear within the list.

Options for the current arrived objects display are syntax checked at the time a page down or page up is performed, or the Enter key is pressed. If an invalid option is selected, the option is displayed in reverse image and the cursor is positioned at that option. A message at the bottom of the display describes the error.

The Enter key can be used to process pending options and/or options newly selected on the currently displayed arrived objects display. It is not required to be at display 1 or a display that has had options selected to use the Enter key to process options. There is no limit on the number of options that can be pending before the Enter key being pressed.

After the pressing of the Enter key and processing of the selected options, the arrived objects display at which the Enter key was pressed is redisplayed.

Objects that were processed are changed in the list of arrived objects to reflect the processing completed on them. For example, suppose the options as shown in Figure 3-17 are selected.

```

                                WORK WITH ARRIVED OBJECTS                                Top
Select object(s) using options listed, press Enter.
  1=Receive into file      2=Receive into folder      3=Receive into library
  4=Delete                 5=View                 6=Print and delete
OPT OBJECT NAME           TYPE  NUM  RECORDS  USER ID /ADDRESS  DATE  TIME
  1  PAYROL.1 M871116     FILE  0080  0000225  JERRY  MELBS36A  041088  102220
  1  PAYROL.2 M871113     AIFILE 0083  0000106  JERRY  MELBS36A  041088  102238
  1  PAYROL.3 M880106     FILE  0087  0000839  JERRY  MELBS36A  041088  102329
  3  PAYLIB  PAY01       LIBR  0095  0002415  JERRY  MELBS36A  041088  103054
  3  ODFADMIN NOTE      DATA  0167  0000092  PAUL   ROCHVMA  061088  225809
  -  #DUMP.10 M881006     DUMP  0188  0002354  JEFF   MELBS36B  121088  172526
  -  #TRACE00 M881006     TRACE 0189  0001537  JEFF   MELBS36B  121088  172925
  4  SYSLIB  PRTINV       JOB   0192  0000125  BECKY  COLL36   121088  173227
  6  QSYSVRT PRTF        PRINT 0216  0000357  CARL   MELB400A  151088  091308
  -  TXTJDELU FOLDER     FLDR  0250  0012070  JEFF   MELBS36B  181088  081553
  -  MYPCDISK M871104     VDISK 0254  0001422  BECKY  COLL36   181088  081630
  -  SAVJLIB  SAVF        SVF400 0257  0006936  CARL   MELB400A  181088  083626
  -  CUSTCDT  M871218     FILE  0258  0000522  BECKY  COLL36   181088  083922
  -  #LIBRARY #CCMQ      PTF   0271  0004789  JEFF   MELBS36B  181088  132924

Cmd1=Subset list      Cmd2=Select User      Cmd3=Go Back  Cmd5=Refresh
Cmd7=End              Cmd8=Reset           Roll=Page

```

Figure 3-17. LISTOBJ Sample Display

After pressing the Enter key and processing the selected options, the arrived objects display would be redisplayed as shown in Figure 3-18.

```

                                WORK WITH ARRIVED OBJECTS                                Top
Select object(s) using options listed, press Enter.
  1=Receive into file      2=Receive into folder      3=Receive into library
  4=Delete                 5=View                 6=Print and delete
OPT OBJECT NAME           TYPE  NUM  RECORDS  USER ID /ADDRESS  DATE  TIME
  *Received
  *Received
  *Received
  *Received
  *Not found
  -  #DUMP.10 M881006     DUMP  0188  0002354  JEFF   MELBS36B  121088  172526
  -  #TRACE00 M881006     TRACE 0189  0001537  JEFF   MELBS36B  121088  172925
  *Deleted
  *Printed
  -  TXTJDELU FOLDER     FLDR  0250  0012070  JEFF   MELBS36B  181088  081553
  -  MYPCDISK M871104     VDISK 0254  0001422  BECKY  COLL36   181088  081630
  -  SAVJLIB  SAVF        SVF400 0257  0006936  CARL   MELB400A  181088  083626
  -  CUSTCDT  M871218     FILE  0258  0000522  BECKY  COLL36   181088  083922
  -  #LIBRARY #CCMQ      PTF   0271  0004789  JEFF   MELBS36B  181088  132924

Cmd1=Subset list      Cmd2=Select User      Cmd3=Go Back  Cmd5=Refresh
Cmd7=End              Cmd8=Reset           Roll=Page

```

Figure 3-18. LISTOBJ Dscreen after Options Processing

- ***Received** shows that the receive operation was successful, and that the object has been received. The object is no longer in your list of arrived objects.
- ***Deleted** shows that the delete operation was successful, and that the object is no longer in your list of arrived objects.
- ***Printed** shows that the print operation was successful, and that the object is no longer in your list of arrived objects.
- ***Not found** shows that the object is no longer in your list of arrived objects. This situation can occur when two users are accessing the the same arrived object for a particular user ID. If the first user carries out a function that removes the object from the list of arrived objects, the second user will get the **Not found* condition.

Allowed options are related to the object type as shown in the TYPE field on the arrived objects display. The object type descriptions and options allowed are:

Type	Description	Allowed Options
AIFILE	System/36 alternative index file sent in S36FMT	1 4
DATA	Flat data. An object sent in DATA format, or an object sent from S/370, or a database file member sent from System/38 or AS/400	1 3 4 5
DUMP FILE	System/36 dump file sent in S36FMT System/36 file sent in S36FMT. The file is a sequential, direct or indexed file, but is not an alternative indexed file, a dump file, a trace file, or a PC virtual disk file	1 4 5 1 4 5
FLDR	System/36 folder	1 2 4 5
JOB	A job stream that was not automatically submitted	1 3 4 5
LIBR	System/36 library member(s) sent in S36FMT, or library member(s) sent from the AS/400 System/36 Environment using SAVS36LIBM and SNDNETF	1 3 4 5
PRINT	A spooled print file	1 4 5 6
PTF	System/36 library member(s) sent in S36FMT that have a PTF applied	1 3 4 5
SVF38	A savefile sent from System/38	1 4 5
SVF400	A savefile sent from AS/400	1 4 5
TRACE	System/36 trace file sent in S36FMT	1 4 5
VDISK	System/36 PC virtual disk file	1 4 5

Figure 3-19. TYPE Descriptions

Alternatively, the valid options for the various object types are as follows:

- 1 = Receive into file** Valid for all objects types.
- 2 = Receive into folder** Valid only for type FLDR.
- 3 = Receive into library** Valid only for types DATA, JOB, LIBR, and PTF.
- 4 = Delete** Valid for all object types.
- 5 = View** Valid for all object types except AIFILE.
- 6 = Print and delete** Valid only for type PRINT.

The following keys can be used on the LISTOBJ display:

Enter key processes all pending options including any options selected on the current arrived objects display. If there are any syntax errors on the current arrived objects display, the first error detected is displayed in reverse image and the cursor will be positioned on that field. A message describing the error appears at the bottom of the display.

Any options selected on the current arrived objects display are held pending, and all pending options are then processed in they order the physically appear within the list of arrived objects.

Page Up and Page Down keys are used to page upward and downward through the list of arrived objects. If there are any syntax errors on the current arrived objects display, the first error detected is displayed in reverse image and the cursor will be positioned on that field. A message describing the error appears at the bottom of the display.

Any options selected on the current arrived objects display, and the objects they relate to are held pending for later processing by the Enter key.

Cmd1 = Subset list allows the list of arrived objects to be subsetted according to selection criteria which is prompted for. Cmd1 is not allowed if there are any options pending or options newly selected on the current arrived objects display.

The subset list function can be used to quickly locate an object in the list, and to make it easier to process related objects. For example, all objects of type LIBR, or all objects from user ID PAUL, and so on.

See "Using the Subset List Function" on page 3-18 for information on how to use the subset list function.

Cmd2 = Select user allows a master security officer, or security officer, to work with another users arrived objects. Cmd2 is not allowed if there are any options pending or options newly selected on the current arrived objects display.

A security officer can work with objects for any users except another security office, or a master security officer. A master security officer can work with objects for any user.

If the list has been subsetted and the select user function is invoked to work with arrived objects for another user ID, the list of arrived objects for the newly selected user ID is subsetted according to the subset list criteria in effect at the time the select user function was invoked.

See Figure 3-20 on page 3-18.

Cmd3 = Go back ignores any pending options and options newly selected on the current arrived objects display and returns you to the previous display.

Cmd5 = Refresh recreates the list of arrived objects and displays the new list. Cmd5 is not allowed if there are any options pending or options newly selected on the current arrived objects display. When the list is refreshed, any objects that have been processed and display as **Received* (for example) will be removed from the list. Also, any objects that have arrived since the list was created will be added to the list and displayed.

Cmd7 = End ignores any pending options and options newly selected on the current arrived objects display and returns you to the previous menu.

Cmd8 = Reset list clears all options pending plus any options newly selected on the current arrived objects display, and repositions you to the first display in the list.

Note: The list is not refreshed. Processed are items are not removed and newly arrived objects are not added to the list.

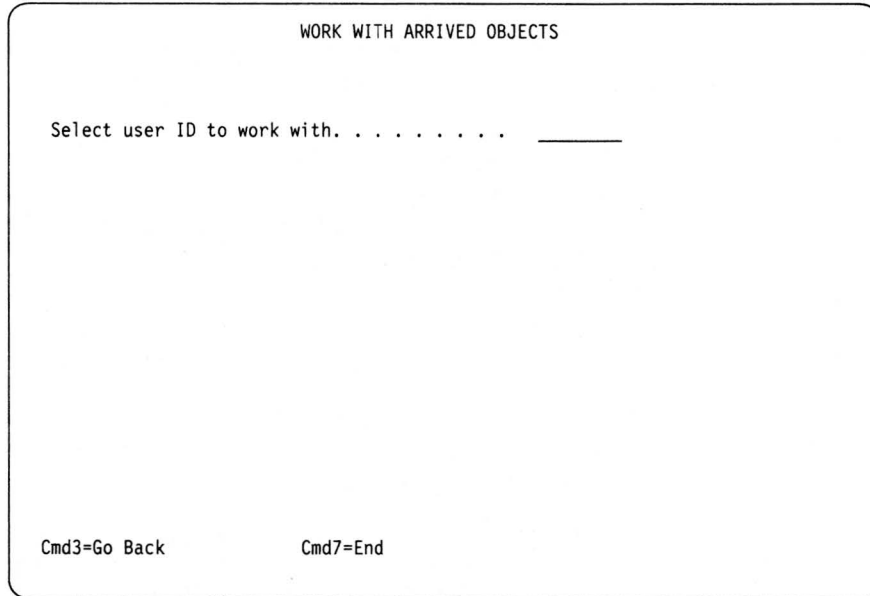

Figure 3-20. LISTOBJ Select User ID Display

Any subset list criteria in effect at the time this function is invoked are preserved for the newly selected user's list of arrived objects.

Using the Subset List Function

The subset list function allows you to:

- Easily manage large lists of arrived objects.
- Quickly locate a specific object.
- Simplify processing of related objects.

The display shown in Figure 3-21 is used to perform the subsetting function.

```

                                SUBSET THE LIST OF OBJECTS

Choose criteria for object list, press Enter.
Selection criteria are: EQ, GE, LE, LT, and GT
SELECTION          SELECTION          VALUE
ITEM               CRITERIA
Object name (1) . . . . . —          _____
Object name (2). . . . . —          _____
Type . . . . . —          _____
Number . . . . . —          _____
Records . . . . . —          _____
Userid . . . . . —          _____
Address . . . . . —          _____
Date . . . . . —          _____
Time . . . . . —          _____

Cmd3=Go back          Cmd7=End          Cmd8=Reset criteria

```

Figure 3-21. Subset List Display

The following keys can be used on the Subset List display:

Enter key processes the input from the display. If there are any syntax errors, the first error detected is displayed in reverse image and the cursor will be positioned on that field. A message appears at the bottom of the display describing the error.

Cmd3 = Go back ignores any input and returns you to the previous display.

Cmd7 = End ignores any input and returns you to the previous menu.

Cmd8 = Reset criteria resets all selection criteria and selection values, then re-creates the list of arrived objects. You will be returned to the first display of the new list of arrived objects.

The subsetted list of arrived objects is made by comparing the *selection value* based on the *selection criteria* with the contents of the *selection item* for each object in the list.

This comparison can be made using the following as selection criteria:

EQ (Equal) specifies that, if the characters in the selection value are the same as the contents of the related selection item, the object is included in the subsetted list.

GE (Greater than or equal to) specifies that, if the characters in the selection value are greater than or the same as the contents of the related selection item, the object is to be included in the subsetted list.

LE (Less than or equal to) specifies that, if the characters in the selection value are less than or the same as the contents of the related selection item, the object is to be included in the subsetted list.

LT (Less than) specifies that, if the characters in the selection value are less than the contents of the related selection item, the object is to be included in the subsetted list.

GT (Greater than) specifies that, if the characters in the selection value are greater than the contents of the related selection item, the object is to be included in the subsetted list.

The selection criteria and selection values for multiple selection items are logically ANDed. For example, if a selection criterion and selection value are specified for *Object name (1)* and a selection criterion and selection value are also specified for *Type*, then both comparisons must be true for the object being tested to be included in the subsetted list.

The list of arrived objects shown in Figure 3-22 will be used for examples of the subset list function.

OBJECT NAME	TYPE	NUM	RECORDS	USER ID /ADDRESS	DATE	TIME		
DICTJAA	FOLDER	FLDR	0054	0001684	JAA	PRODS36	250988	154461
DIRFILE	M860404	FILE	0055	0001000	JAA	PRODS36	250988	154220
EMPJAA	M860924	FILE	0056	0000107	JAA	PRODS36	250988	152220
JAASAVE	BI04	LIBR	0058	0000198	JAA	PRODS36	250988	152220
JPROCS	ADDCPY	LIBR	0059	0000583	JAA	PRODS36	250988	152220
PLDFILE	M880928	FILE	0066	0000136	JEFF	MELBS36B	280988	204556
\$NETDOC	LISTING	PRINT	0073	0000851	CWR	COLLVMC	011088	102220
QTXTSRC	X101	DATA	0075	0000033	QPGMR	DEV38	021088	102220
QTXTSRC	X102	DATA	0076	0000042	QPGMR	DEV38	021088	102220
PCDATA	M871116	VDISK	0078	0000664	JEFF	MELBS36B	031088	102220
S36ARC	S36ARC	36E400	0079	0000237	CARL	MELB400A	031088	102220
PAYROL.1	M880516	FILE	0081	0000763	JERRY	MELBS36A	041088	102220
PAYROL.2	M880513	FILE	0082	0000225	JERRY	MELBS36A	041088	102220
PAYROL.3	M880516	AIFILE	0083	0000106	JERRY	MELBS36A	041088	102238
PAYROL.4	M880806	FILE	0087	0000839	JERRY	MELBS36A	041088	102329
PAYLIB	PAY01	LIBR	0095	0002415	JERRY	MELBS36A	041088	103054
ODFADMIN	NOTE	DATA	0167	0000092	PAUL	COLLVMA	061088	225809
#DUMP.10	M881006	DUMP	0188	0002354	JEFF	MELBS36B	121088	172526
#TRACE00	M881006	TRACE	0189	0001537	JEFF	MELBS36B	121088	172925
SYSLIB	PRTINV	JOB	0192	0000125	BECKY	COLL36	121088	173227
QSYSPRT	PRTF	PRINT	0216	0000357	CARL	MELB400A	151088	091308
TXTJDELU	FOLDER	FLDR	0250	0012070	JEFF	MELBS36B	181088	081553
MYPCDISK	M871104	VDISK	0254	0001422	BECKY	COLL36	181088	081630
SAVJLIB	SAVF	SVF400	0257	0006936	CARL	MELB400A	181088	083626
CUSTCDT	M871218	FILE	0258	0000522	BECKY	COLL36	181088	083922
#LIBRARY	#CCMQ	PTF	0271	0004789	JEFF	MELBS36B	181088	132924

Figure 3-22. Arrived Objects List for Subset Examples

Example 1

To process all arrived objects of type FILE, the subset list function can be used to provide a list of only objects of type FILE. The subset would be created by specifying as shown in Figure 3-23.

```

SUBSET THE LIST OF OBJECTS

Choose criteria for object list, press Enter.
Selection criteria are: EQ, GE, LE, LT, and GT
SELECTION          SELECTION          VALUE
ITEM               CRITERIA
Object name (1) . . . . . _____
Object name (2) . . . . . _____
Type . . . . . EQ                      FILE
Number . . . . . _____
Records . . . . . _____
Userid . . . . . _____
Address . . . . . _____
Date . . . . . _____
Time . . . . . _____

Cmd3=Go back          Cmd7=End          Cmd8=Reset criteria

```

Figure 3-23. Subset List Example 1, Display 1

After you type the information shown in Figure 3-23 and press Enter, the arrived objects display shown in Figure 3-24 appears.

```

WORK WITH ARRIVED OBJECTS
All

Select object(s) using options listed, press Enter.
1=Receive into file      2=Receive into folder      3=Receive into library
4=Delete                 5=View                      6=Print and delete

OPT OBJECT NAME      TYPE  NUM  RECORDS  USER ID /ADDRESS  DATE  TIME
-   DIRFILE  M860404  FILE  0055  0001000  JAA  PRODS36  250988  154220
-   EMPJAA   M860924  FILE  0056  0000107  JAA  PRODS36  250988  152220
-   PLDFILE  M880928  FILE  0066  0000136  JEFF MELBS36B  280988  204556
-   PAYROL.1 M880516  FILE  0081  0000763  JERRY MELBS36A  041088  102220
-   PAYROL.2 M880513  FILE  0082  0000225  JERRY MELBS36A  041088  102220
-   PAYROL.4 M880806  FILE  0087  0000839  JERRY MELBS36A  041088  102329
-   CUSTCDT  M871218  FILE  0258  0000522  BECKY COLL36  181088  083922

Cmd1=Subset list      Cmd2=Select User      Cmd3=Go Back  Cmd5=Refresh
Cmd7=End              Cmd8=Reset            Roll=Page

```

Figure 3-24. Subset List Example 1, Display 2

Example 2

To process all objects that have arrived since the 1st of October 1988 and that are from an address that begins MELB or greater and that are 200 records or more, you would specify as shown in Figure 3-25.

```

SUBSET THE LIST OF OBJECTS

Choose criteria for object list, press Enter.
Selection criteria are: EQ, GE, LE, LT, and GT
SELECTION          SELECTION          VALUE
ITEM              CRITERIA
Object name (1) . . . . . —           _____
Object name (2) . . . . . —           _____
Type . . . . . —                       _____
Number . . . . . —                     _____
Records . . . . . GE                   200
Userid . . . . . —                     _____
Address . . . . . GE                    MELB
Date . . . . . GT                      011088
Time . . . . . —                       _____

Cmd3=Go back          Cmd7=End          Cmd8=Reset criteria
    
```

Figure 3-25. Subset List Example 2, Display 1

After you type the information show in Figure 3-25 and press Enter, the arrived objects display shown in Figure 3-26 appears.

```

WORK WITH ARRIVED OBJECTS
All

Select object(s) using options listed, press Enter.
1=Receive into file      2=Receive into folder      3=Receive into library
4=Delete                5=View                      6=Print and delete

OPT OBJECT NAME      TYPE  NUM  RECORDS  USER ID /ADDRESS  DATE  TIME
-   PCDATA  M871116    VDISK  0078  0000664  JEFF  MELBS36B  031088  102220
-   S36ARC  S36ARC    36E400  0079  0000237  CARL  MELB400A  031088  102220
-   PAYROL.1 M880516    FILE   0081  0000763  JERRY MELBS36A  041088  102220
-   PAYROL.2 M880513    FILE   0082  0000225  JERRY MELBS36A  041088  102220
-   PAYROL.4 M880806    FILE   0087  0000839  JERRY MELBS36A  041088  102329
-   PAYLIB  PAY01     LIBR   0095  0002415  JERRY MELBS36A  041088  103054
-   #DUMP.10 M881006    DUMP   0188  0002354  JEFF  MELBS36B  121088  172526
-   #TRACE00 M881006    TRACE  0189  0001537  JEFF  MELBS36B  121088  172925
-   QSYSVRT PRTF     PRINT  0216  0000357  CARL  MELB400A  151088  091308
-   TXTJDELU FOLDER  FLDR   0250  0012070  JEFF  MELBS36B  181088  081553
-   SAVJLIB  SAVF     SVF400  0257  0006936  CARL  MELB400A  181088  083626
-   #LIBRARY #CCMQ    PTF    0271  0004789  JEFF  MELBS36B  181088  132924

Cmd1=Subset list      Cmd2=Select User      Cmd3=Go Back      Cmd5=Refresh
Cmd7=End              Cmd8=Reset            Roll=Page
    
```

Figure 3-26. Subset List Example 2, Display 2

General Information on Processing Objects

Options selected from the arrived objects display(s) are processed in the order they physically appear within the list of arrived objects.

The following keys can be used on all the options displays.

Enter key processes the input from the display. If there are any syntax errors, the first error detected is displayed in reverse image and the cursor positioned on that field. A message appears at the bottom of the display describing the error.

Cmd3 = Go back ignores any input and returns you to the arrived objects display at which the Enter key was pressed.

All options processed for list entries before this object are no longer pending. All options for list entries after and including this object are still pending.

The cursor will be positioned at the option field on the arrived objects display for this object.

Cmd7 = Ignore option ignores the current option and processes the next pending option. The current option is no longer pending or selected. If there are no more pending options, the arrived objects display from which the Enter key was pressed is redisplayed.

Option 1 (Receive into File) Processing

DEFINE FILE TO RECEIVE OBJECT				
OBJECT NAME	NUM	USER ID	/ ADDRESS	
PAYROL.1	M880516	0081	JERRY	MELBS36A
Type choices, press Enter.				
ITEM	CHOICE		POSSIBLE CHOICES	
File name	PAYROL.1		Name of file where you want object to be received.	
Replace existing file . . .	2		1 = Yes 2 = No	
Cmd3=Go back Cmd7=Ignore receive				

Figure 3-27. Receive into File Display

File name is the name of a disk file where the object is to be received. A file will be created if one does not exist. This parameter is set to the object name part 1, but can be changed to any valid file name.

Replace existing file indicates whether a file will be replaced.

Specify a 1 to indicate that if a file of the same name already exists on disk, then it is to be replaced. Specify a 2 to indicate that an existing disk file of the same name should not be replaced.

Note: If the system is configured for date differentiated files, then specifying a 1 for *Replace existing file* results in the file being replaced if a file of the same name and creation date exists, or, in a date differentiated file being created, if a file of the same name but a different creation date exists.

Specifying a 2 will result in an error if a file of the same name and creation date exists, or, in a date differentiated file being created, if a file of the same name but a different creation date exists.

See “General Information on Processing Objects” on page 3-22 for information on the keys available on this display.

Option 2 (Receive into Folder) Processing

```

                                DEFINE FOLDER TO RECEIVE OBJECT

OBJECT NAME          NUM      USER ID / ADDRESS
TXTJDELU FOLDER     0250     JEFF      MELBS36B

Type choices, press Enter.

ITEM                CHOICE      POSSIBLE CHOICES
Folder name . . . . . TXTJDELU   Name of folder to contain object
Replace existing folder . . 2      1 = Yes  2 = No

Cmd3=Go back   Cmd7=Ignore receive
    
```

Figure 3-28. Receive into Folder Display

Folder name is the name of a folder where the object is to be received. A folder will be created if one does not exist. This parameter is set to the object name part 1, but can be changed to any valid folder name.

Replace existing folder indicates whether a folder is to be replaced.

specify a 1 to indicate that if a folder of the same name already exists on disk, then it is to be replaced. Specify a 2 to indicate that an existing folder of the same name should not be replaced.

See "General Information on Processing Objects" on page 3-22 for information on the keys available on this display.

Option 3 (Receive into Library) Processing

The display displayed for receiving objects into a library depends on the type of object being received. If the object type is DATA or JOB, then a member name and member type as well as the library name can be specified for the library being received into. If the object type is LIBR or PTF, then only the library name can be specified, as the object contains directory information for the member(s) that comprise the object, and this directory information is used to re-create the member name(s) and member type(s). See "SENDLIBR Procedure" on page 3-67 for information on the format of objects that are library member(s).

```

                                DEFINE LIBRARY TO RECEIVE OBJECT
OBJECT NAME          NUM      USER ID / ADDRESS
#LIBRARY #CCMQ      0271    JEFF      MELBS36B
Type choices, press Enter..
ITEM                  CHOICE      POSSIBLE CHOICES
Library name. . . . . #LIBRARY    Name of library to contain object

Cmd3=Go back   Cmd7=Ignore receive

```

Figure 3-29. Receive into Library Display for Type LIBR or PTF

```

                                DEFINE LIBRARY TO RECEIVE OBJECT
OBJECT NAME          NUM      USER ID / ADDRESS
QXTSRC X101         0075    QPGMR      DEV38
Type choices, press Enter..
ITEM                  CHOICE      POSSIBLE CHOICES
Library name. . . . . QXTSRC      Name of library to contain object
Name of member . . . . . X101
Type of member. . . . . S          S = Source P = Procedure

Cmd3=Go back   Cmd7=Ignore receive

```

Figure 3-30. Receive into Library Display for Type DATA or JOB

Library name is the name of the library where the object is to be received. The library must already exist on the system. This parameter is set to the object name part 1, but can be changed to any valid existing library name.

If this is not the first *Receive into library* operation, then the library name will be set to the last entered library name when this display is first displayed.

Name of member specifies the name of the member to be created for the type DATA or JOB object. This parameter is set to the object name part 2, but can be changed to any valid member name.

Type of member specifies the type of member to be created for the type DATA or JOB object. S specifies that a library source member is to be created. P specifies that a library procedure member is to be created.

Note: There is an implicit replace performed for all receive into library operations. That is, any existing library members of the same name are replaced.

LISTOBJ

See “General Information on Processing Objects” on page 3-22 for information on the keys that can be used on the receive into library displays. See “SENDLIBR Procedure” on page 3-67 for information on the format and naming conventions of objects sent as library members.

Option 4 (Delete) Processing

CONFIRM DELETE

OBJECT NAME	NUM	USER ID	/ ADDRESS
ODFADMIN NOTE	0167	PAUL	COLLVMA

Will be deleted. Press Enter if you wish this action to take place.

Cmd3=Go back Cmd7=Ignore delete

Figure 3-31. Delete Object Confirmation Display

A confirmation display is displayed for each list entry selected for deletion, allowing the delete operation to be ignored if inadvertently selected.

See “General Information on Processing Objects” on page 3-22 for information on the keys that can be used on this display.

Option 5 (View) Processing

```

#LIBRARY APPNINFO 0057 JEFF      MELBS36B      Rec1 0080      Rec      1 of 0000097
.....10.....20.....30.....40.....50.....60.....70.....80

// LIBRARY NAME-0
// MEMBER PROGRAM1-#LS#M1
// IF JOBQ-YES #ERR 8991,3,SYS      IF JOBQ ISSUE ERROR
// IF JOBQ-YES RETURN              IF JOBQ RETURN
// IF EVOKED-YES #ERR 8991,3,SYS    IF EVOKED ISSUE ERROR
// IF EVOKED-YES RETURN              IF EVOKED RETURN
// IFF ?1'NETWORK'?/NETWORK IFF ?1?/LOCATIONS IFF ?1?/SESSION +
#ERR 6980,3,SYS,' 1'
// TAG DEVCHK
// IFF ?2'CRT'?/CRT IFF ?2?/PRINTER #ERR 6986,3,SYS,' 2'
// LOCAL BLANK-*ALL,AREA-SYSTEM
// IF ?2?/CRT LOCAL OFFSET-9,DATA-'CR',AREA-SYSTEM
// ELSE LOCAL OFFSET-9,DATA-'PR',AREA-SYSTEM
// IF ?1?/LOCATIONS LOAD $LSLUD
// ELSE IF ?1?/NETWORK LOAD $LSTDB
// IFF ?1?/SESSION GOTO RUNTIME
// IFF ?5'TIME'?/TIME IFF ?5?/PCID #ERR 8990,3,SYS,' 5'
// IF ?5?/TIME LOCAL OFFSET-36,DATA-'O',AREA-SYSTEM

Cmd1=Go to top      Cmd2=Go to bottom      Cmd3=Go Back      Cmd7=End this view

```

Figure 3-32. View Object Display

This function allows you to view the contents of an object before processing it. Eighteen lines by 80 columns of object data is displayed at a time; however, if your display terminal is wide-mode capable, then 27 lines by 132 columns of object data is displayed. The Page Up and Page Down keys can be used to page through the object data.

Any nondisplayable characters are displayed as a period (.).

Cmd1 = Go to top can be used to position to the first page of the object data.

Cmd2 = Go to bottom can be used to position to the last page of object data.

See “General Information on Processing Objects” on page 3-22 for information on the keys, besides Cmd1, Cmd2, and the Page Up and Page Down keys, that can be used on this display.

Option 6 (Print and Delete) Processing

```

                                DEFINE PRINTER OVERRIDES
OBJECT NAME          NUM      USER ID / ADDRESS
QSYSPRT  PRTF      0216    CARL      MELB400A

Type choice, press Enter..

ITEM                CHOICE      POSSIBLE CHOICES
Printer ID. . . . . SYSTEM      ID, SYSTEM
Forms number. . . . . *STD
Number of copies. . . . . 001      1-255
Priority. . . . . 1      0-5

Cmd3=Go back  Cmd7=Ignore print
    
```

Figure 3-33. Print and Delete Display

Printer ID specifies which printer on the system is to be used for the printing of this spooled print file object.

This value is set from the user's ODF/36 profile, or from the ODF/36 system defaults if the user has no ODF/36 profile.

Forms number specifies the forms number to be used for printed output.

This value is set from the spooled print file attributes.

Copies specifies the number of copies to be printed.

This value is set from the spooled print file attributes.

Priority specifies the priority for printed output.

The system prints spool file entries with higher priority numbers before entries with lower priority numbers. Spool file entries with the same priority are printed in the order that they were placed on the spool file. Priority 0 entries are placed in the spool file with a priority of 1 but are held. These entries are not printed until a RELEASE control command is entered.

This value is set from the user's ODF/36 profile, or from the ODF/36 system defaults if the user has no ODF/36 profile.

This display allows all the above parameters to be overridden before processing the object.

Outputting the List of Arrived Objects to a Disk File

Example 1: To list your arrived objects to disk file MYLIST, enter:

```
LISTOBJ MYLIST
```

Example 2: To list the arrived objects for user ID PAUL to disk file ARRIVED, enter:

```
LISTOBJ ARRIVED,PAUL
```

Note: A security officer can list objects for any users except another security officer or a master security officer. A master security officer can list objects for any user.

A sequential disk file is created with one record for each arrived object. The record length of the file is 64 bytes.

Beginning Column	Field Length	Contents or Description
1	1	This field is unused
2	8	Object name part 1
10	1	This field is unused
11	8	Object name part 2
19	6	Object type
25	4	Sequence number
29	7	Number of records that comprise the object
36	8	User ID from which the object was sent
44	8	Address from which the object was sent
52	6	Date the object arrived
58	6	Time the object arrived
64	1	This field is unused

Figure 3-34. Record Format for LISTOBJ to a Disk File

LISTRSCS procedure

This procedure displays a list of objects that are queued on an RSCS link.

```
LISTRSCS      link name
```

R36L023-1

link name specifies the name of the RSCS link for which queued objects are to be displayed.

LIST OF RSCS QUEUE ENTRIES							A11
RSCS queue	MELBVMA						
Type choices, press Enter							
4=Delete							
OPTION	OBJECT NAME	NUM	FROM USERID	/ADDRESS	TO USERID	/ADDRESS	
-	FILE.1	M880309	0004	JEFF	MELBS36B	ADMIN MELBS36A	
-	FILE.1	M880309	0004	JEFF	MELBS36B	ADMIN MELBS36C	
-	FILE.1	M880309	0004	JEFF	MELBS36B	ADMIN MELBS36D	
-	FILE.1	M880309	0004	JEFF	MELBS36B	ADMIN COLLS36	
-	FILE.1	M880309	0004	JEFF	MELBS36B	ADMIN ADELSYS	
-	FILE.1	M880309	0004	JEFF	MELBS36B	ADMIN SYDNSYS	
-	FILE.1	M880309	0004	JEFF	MELBS36B	PAUL COLLVMA	
-	JPROCS	ADDCPY	0059	JAA	PRODS36	JDELUCA RCHVM1	
-	PLDFILE	M880928	0066	JEFF	MELBS36B	BECKY COLLS36	
-	PCDATA	M871116	0078	JEFF	MELBS36B	BECKY COLLS36	
-	QSYSVRT	PRTF	0216	CARL	MELB400A	FRED ADEL400	
-	SAVJLIB	SAVF	0257	CARL	MELB400A	FRED ADEL400	
-	CUSTCDT	M871218	0258	JAA	PRODS36	JERRY MELBS36A	
-	#LIBRARY	#CCMQ	0271	JEFF	MELBS36B	JERRY MELBS36A	
Cmd3=Go back	Cmd5=Refresh	Cmd7=End	Cmd8=Reset list	Roll=Page			

Figure 3-35. List of Entries for an RSCS Link

From this display, the objects queued on the specified RSCS link can be deleted by typing the delete option (4) in the option column.

Explanation of the column headings on the RSCS queue entries display:

Column heading	Description
OPTION	Input option
OBJECT NAME	Name of the queued object. Each object has a two-part name.
NUM	Sequence number. A 4-digit number assigned by Object Distribution Facility/36 to assist in uniquely identifying queued objects.
FROM USER ID	User from which the object was sent.
FROM ADDRESS	Address from which the object was sent.
TO USER ID	User to which the object is being sent.
TO ADDRESS	Address to which the object is being sent.

The list of arrived objects may be larger than one display (14 entries); the Page Up and Page Down keys can be used to page through the list of queued objects.

The top right-hand corner of the RSCS queue entries display will show the following:

- All** The entire list of queue entries for the RSCS link is displayed. There are 14 objects or less.
- Bottom** This is the last display of queue entries for the RSCS link. There are more than 14 objects comprising the list. The Page Up key can be used to page upward through the list of RSCS queue entries.
- More** This display is between the first and last page of queue entries for the RSCS link. There are more than 28 objects comprising the list. The Page Up and Page Down keys can be used to page through the list of RSCS queue entries.
- Top** This is the first display of the list of queue entries for the RSCS link. There are more than 14 objects comprising the list. The Page Down key can be used to page downward through the list of RSCS queue entries.

Delete options can be typed on multiple displays that constitute the total list of RSCS queue entries, and are held pending until the Enter key is pressed. At this time, all pending delete options are processed in the order they appear in the list of RSCS queue entries.

Figure 3-36 shows how the LISTRSCS function logically works.

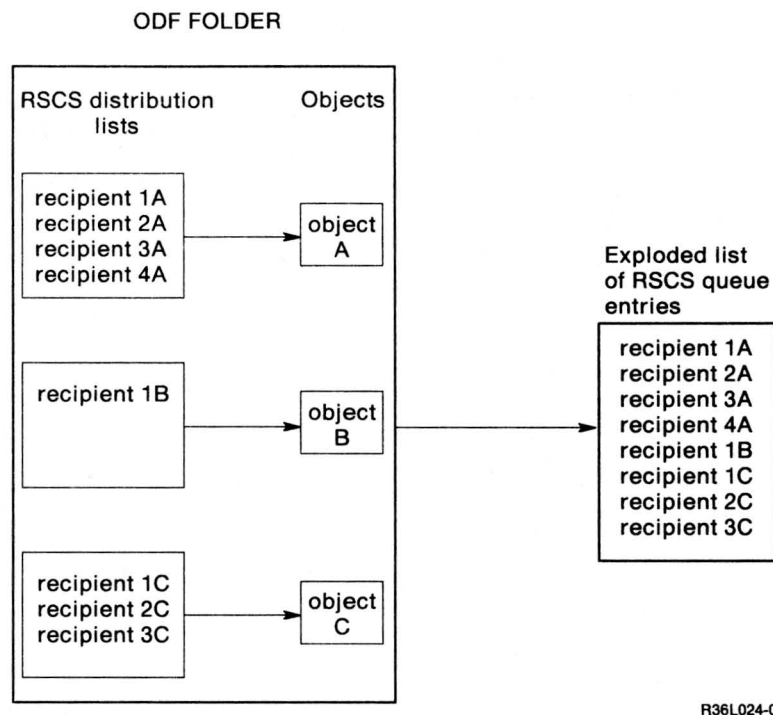

Figure 3-36. How the LISTRSCS Function Logically Works. The ODF folder is searched for all RSCS distribution lists for the specified RSCS link. The RSCS distribution lists point to the actual objects to be sent; there is only ever one copy of the actual object to be sent. There can be up to 150 remote recipients in each RSCS distribution list.

The information in the RSCS distribution list, that is, the recipients user IDs and addresses, is merged with the information associated with the actual object, that is, the object name and so on.

An exploded list of RSCS queue entries is created and displayed. There can be multiple entries in the exploded list that point to the same actual object to be sent.

When a delete operation is requested against an entry in the list, that recipient is removed from the RSCS distribution list. If there are no more entries in the RSCS distribution list, the distribution list itself is deleted.

If an object is actually being sent, then a delete option for any entries in the exploded list for that actual object will fail, because the RSCS distribution list is exclusively allocated by the sending RSCS link task.

There can be many displays that constitute the total list of RSCS queue entries. When the Enter key is pressed, the pending delete options will be processed in the order they appear within the list.

Options for the current RSCS queue entries display are syntax checked at the time a Page Up or Page Down is performed, or the Enter key is pressed. If an invalid option has been selected, the option is displayed in reverse image and the cursor is positioned at that option. A message at the bottom of the display describes the error.

The Enter key can be used to process those options that are pending and/or newly selected on the currently displayed RSCS queue entries display. It is not required to be at display 1 or a display that has had options selected to use the Enter key to

process options. There is no limit on the number of options that can be pending before the Enter key being pressed.

After pressing the Enter key and processing of the selected options, the RSCS queue entries display at which the Enter key was pressed is redisplayed.

Objects that were processed are changed in the list of RSCS queue entries to reflect the processing completed on them. For example, the options as shown in Figure 3-37 are selected.

LIST OF RSCS QUEUE ENTRIES								A11	
RSCS queue	MELBVMA								
Type choices, press Enter									
4=Delete									
OPTION	OBJECT	NAME	NUM	FROM	USERID	/ADDRESS	TO	USERID	/ADDRESS
-	FILE.1	M880309	0004	JEFF	MELBS36B	ADMIN	MELBS36A		
-	FILE.1	M880309	0004	JEFF	MELBS36B	ADMIN	MELBS36C		
-	FILE.1	M880309	0004	JEFF	MELBS36B	ADMIN	MELBS36D		
-	FILE.1	M880309	0004	JEFF	MELBS36B	ADMIN	COLLS36		
4	FILE.1	M880309	0004	JEFF	MELBS36B	ADMIN	ADELSYS		
-	FILE.1	M880309	0004	JEFF	MELBS36B	ADMIN	SYDNSYS		
-	FILE.1	M880309	0004	JEFF	MELBS36B	PAUL	COLLVMA		
-	JPROCS	ADDCPY	0059	JAA	PRODS36	JDELUCA	RCHVM1		
4	PLDFILE	M880928	0066	JEFF	MELBS36B	BECKY	COLLS36		
4	PCDATA	M871116	0078	JEFF	MELBS36B	BECKY	COLLS36		
-	QSYSPRT	PRTF	0216	CARL	MELB400A	FRED	ADEL400		
-	SAVJLIB	SAVF	0257	CARL	MELB400A	FRED	ADEL400		
-	CUSTCDT	M871218	0258	JAA	PRODS36	JERRY	MELBS36A		
-	#LIBRARY	#CCMQ	0271	JEFF	MELBS36B	JERRY	MELBS36A		
Cmd3=Go back	Cmd5=Refresh	Cmd7=End	Cmd8=Reset list	Roll=Page					

Figure 3-37. LISTRSCS Sample Display

After pressing the Enter key and processing of the selected delete options, the RSCS queue entries display would be redisplayed as shown in Figure 3-38.

LIST OF RSCS QUEUE ENTRIES							A11	
RSCS queue	MELBVMA							
Type choices, press Enter								
4=Delete								
OPTION	OBJECT NAME	NUM	FROM	USERID	/ADDRESS	TO	USERID	/ADDRESS
-	FILE.1	M880309	0004	JEFF	MELBS36B	ADMIN	MELBS36A	
-	FILE.1	M880309	0004	JEFF	MELBS36B	ADMIN	MELBS36C	
-	FILE.1	M880309	0004	JEFF	MELBS36B	ADMIN	MELBS36D	
-	FILE.1	M880309	0004	JEFF	MELBS36B	ADMIN	COLLS36	
*Not found								
-	FILE.1	M880309	0004	JEFF	MELBS36B	ADMIN	SYDNSYS	
-	FILE.1	M880309	0004	JEFF	MELBS36B	PAUL	COLLVMA	
-	JPROCS	ADDCPY	0059	JAA	PRODS36	JDELUCA	RCHVM1	
*Deleted								
*Deleted								
-	QSYSPRT	PRTF	0216	CARL	MELB400A	FRED	ADEL400	
-	SAVJLIB	SAVF	0257	CARL	MELB400A	FRED	ADEL400	
-	CUSTCDT	M871218	0258	JAA	PRODS36	JERRY	MELBS36A	
-	#LIBRARY	#CCMQ	0271	JEFF	MELBS36B	JERRY	MELBS36A	
Cmd3=Go back		Cmd5=Refresh		Cmd7=End		Cmd8=Reset list		

Figure 3-38. LISTRSCS Display after Options Processing

***Deleted** shows that the delete operation was successful, and the object for the remote recipient is no longer in the list of RSCS queue entries.

***Not found** shows that the object is no longer the list of RSCS queue entries. This situation can occur when two users are processing RSCS queue entries for the same RSCS link. If the first user selects and processes a delete option, the second user will get the *not found* condition. This situation can also occur if the object has already been sent to the next RSCS system, before the delete option is processed.

The following keys can be used on the LISTRSCS display:

Enter key processes all pending options including any options newly selected on the current RSCS queue entries display. If there are any syntax errors on the current RSCS queue entries display, the first error detected is displayed in reverse image and the cursor is positioned on that field. A message describing the error is displayed at the bottom of the display.

Any options newly selected on the current RSCS queue entries display are held pending, and all pending options are then processed in the order they physically appear within the list of RSCS queue entries.

Page Up and Page Down keys are used to page through the list of RSCS queue entries. If there are any syntax errors on the current RSCS queue entries display, the first error detected is displayed in reverse image and the cursor is positioned on that field. A message describing the error is displayed at the bottom of the display.

Any options typed on the current RSCS queue entries display and the objects they relate to are held pending for later processing by the Enter key.

Cmd3 = Go back ignores any pending options and options newly selected on the current RSCS queue entries display and returns you to the previous display.

Cmd5 = Refresh re-creates the list of RSCS queue entries and displays the new list. Cmd5 is not allowed if there are any options pending or options newly selected on the current RSCS queue entries display. When the list is refreshed, any objects that have been processed and now display as **Deleted* (for example) are removed from the list. Also, any objects that have been queued since the list was created are added to the list and displayed.

Cmd7 = End ignores any pending options and options newly selected on the current RSCS queue entries display and returns you to the previous menu.

Cmd8 = Reset list clears all options pending plus any options newly selected on the current RSCS queue entries display, and repositions you to the first display in the list.

Note: The list is not refreshed. Processed items are not removed and newly queued objects will not be added to the list.

MSG Control Command

You can use the MSG control command to:

- Display messages that were sent to your display station.
- Display a system console message that was also sent to your display station (for your information). Such a message is called a **dual routed message**.
- Send a message to the system console, to another display station, or to another operator.
- Send a message to all display stations.
- Send messages to or receive messages from personal computers that are attached to System/36, or the AS/400 system, via the IBM Token-Ring Network.
- Send a message to a user on another system. Using Object Distribution Facility/36, this message can be sent to users on another System/36, System/38, AS/400 system, or S/370.

Note: The message receiver of a personal computer must be active if the personal computer is to receive a message.

Messages received by a display station or operator are placed in the system message file (#MESSAGE). When an initial program load (IPL) is done, messages that were sent to a specific display station are removed from the message file. Messages that were sent to a specific operator and are more than seven days old are also removed from the message file when an IPL is done.

The MSGFILE procedure can be used to:

- Define the size and location of the message file.
- List the display stations and users that have messages in the message file.
- Remove messages from the message file.

For more information about the MSGFILE procedure, see the *IBM System/36 System Reference Manual*.

If an operator is signed on to the display station when a message is sent, the audible alarm sounds and the Message Waiting light comes on. Up to 25 messages can be waiting to be displayed for any display station or operator. If an attempt is made to send a message when 25 messages are waiting to be displayed, the messages are not placed in the message file and the sender is notified that the display station or the operator cannot receive messages at this time.

If an operator is signed on to more than one display station when a message is sent to a specific operator, the audible alarm sounds and the Message Waiting light comes on at all of the display stations that the operator is signed on to. The message is displayed at the first display station that requests that the message be displayed. After the message is displayed, the Message Waiting light is reset at all of the display stations that the operator is signed on to.

If an operator is not signed on when a message is sent and an entry in the user identification file exists for that operator, that message is placed in the message file. The message is displayed when the operator signs on. If the operator does not have an

entry in the user identification file, the sender is notified that the message cannot be sent to that operator.

Messages sent to a display station are displayed when:

- An operator signs on the display station.
- An operator enters the OFF command (except when OFF DROP is specified on a switched communications line).
- The operator enters the MSG command with no parameters.
- A job being run from the display station ends.
- The operator switches from command mode to console or subconsole mode.

Network, as used in the following discussion, can consist of System/36s and PCs attached to System/36s, System/38s, AS/400 systems and PCs attached to AS/400 systems, and S/370s.

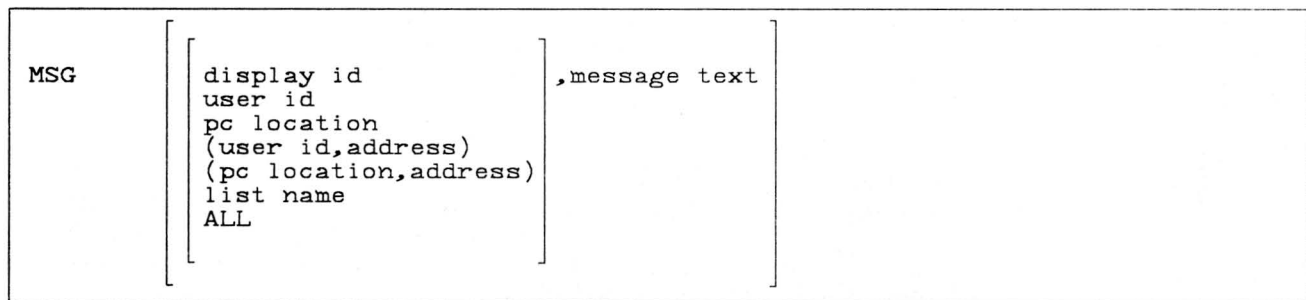

R36L025-0

If no parameters are specified, the messages in the message file for the display station are displayed. If the first parameter is not entered but the second one is, the message is sent to the system console.

display ID specifies the 2-character ID of the display station to which the message is to be sent. The STATUS WORKSTN command can be used to determine the display station IDs.

user id specifies the 1- to 8-character user ID that identifies the operator to whom the message is to be sent. The STATUS WORKSTN command can be used to determine the user IDs of operators who are signed on.

If you specify the user ID of the system operator, the message is sent to the command display of the system console. (The message can be viewed from the console display.)

pc location specifies the 1- to 8-character personal computer location name in the IBM Token-Ring Network to which the message is to be sent. You can use the STATUS SUBSYS control command to determine the personal computer locations that are currently active.

MSG Control Command

(user id,address) specifies the 1- to 8-character user ID and the 1- to 8-character address that together identify a user in the network to whom the message is to be sent. The user ID and address must already exist in the directory.

(pc location,address) specifies the 1- to 8-character personal computer location name in the IBM Token-Ring Network and the 1- to 8-character address that together identify the personal computer location name in the network to which the message is to be sent. The PC location name and address must already exist in the directory.

list name specifies the name of the distribution list given in a System/36 directory that identifies a list of users in the network to which the message is sent.

Note: A distribution list name cannot have the same name as a user ID.

ALL specifies that the message is to be sent to all active display stations, except the display station itself.

message text specifies the message to be sent. Up to 75 alphanumeric or special characters can be entered. The message text can contain IGC characters; however, the message will not be sent to a nonideographic display station. If you try to send an ideographic message to a nonideographic display station, an error message is displayed.

Example 1

A display station operator is preparing to submit a job that requires diskette BFILE. To inform the system operator that diskette BFILE is required, the display station operator enters:

```
MSG ,PLEASE PUT DISKETTE BFILE INTO SLOT 1
```

Example 2

To notify the operator at display station W4 that no more jobs can be entered, the system operator enters:

```
MSG W4,PLEASE DO NOT SUBMIT ANY MORE JOBS
```

Example 3

To send a message to a message to a list of users identified by the distribution list name DEPT007, the display station operator enters:

```
MSG DEPT007,TODAY'S MEETING HAS BEEN CANCELED
```

Example 4

To send a message to a remote user identified by user ID JERRY and address MELBSYS, the display station operator enters:

```
MSG (JERRY,MELBSYS),PLEASE SEND ME THE TRANSACTION FILE
```

ODF Procedure

The ODF procedure command displays the ODF/36 main menu, shown in Figure 3-1 on page 3-2.



ODF

R36L013-0

The ODF procedure has no parameters.

ODFCANCL Procedure

The ODFCANCL procedure stops Object Distribution Facility/36 background tasks including all RSCS links that may be active.

ODFCANCL can be used when a dedicated system is required.

The ODFSTART procedure, see “ODFSTART Procedure” on page 3-46, can be used to restart the Object Distribution Facility/36 background tasks.

Note: ODFCANCL stops only Object Distribution Facility/36 background tasks. The OFCCANCL procedure must be used to stop the Personal Services/36 (SNADS) background communications tasks. See “OFCCANCL Procedure” on page 3-46



ODFCANCL

R36L015-0

The ODFCANCL procedure has no parameters.

ODFDFLT Procedure

The ODFDFLT procedure changes the default values used by Object Distribution Facility/36.

To change the system name, the OFCDFLT procedure, which is part of the SNADS portion of Personal Services/36 must be used. See "OFCDFLT Procedure" on page 3-49.

If password security is active, only a security officer can change system default values.

For detailed information about setting the default values, see "Object Distribution Facility/36 Defaults" on page 2-10.

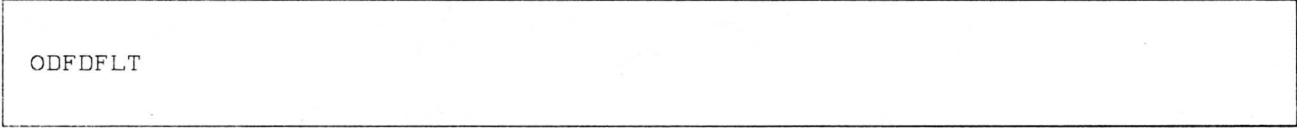

R36L016-0

The ODFDFLT procedure has no parameters.

ODFINSTL Procedure

The ODFINSTL procedure initializes Object Distribution Facility/36 for use on the system by setting up the support files, folders, and default values used by Object Distribution Facility/36.

To complete the environment initialization, the OFCINSTL procedure must be run to initialize Personal Services/36 (SNADS). See "OFCINSTL Procedure" on page 3-51 and "Initializing Personal Services/36 (SNADS)" on page 2-13.

For detailed information see "Initializing Object Distribution Facility/36" on page 2-5.



R36L017-0

The ODFINSTL procedure has no parameters.

ODFIPL Procedure

This procedure *must* be run each time your system is IPLed. The system administrator should add the ODFIPL procedure to the system dedicated startup procedure #STRUP1. See the *IBM System/36 System Reference Manual*, for instructions on how to perform this task.

ODFIPL prepares the Object Distribution Facility/36 environment by performing the following tasks:

1. Objects in the ODF folder (#ODFFLDR) that have exceeded the object purge interval, are deleted. An entry for each object that is deleted is made in the ODF distribution log.
2. Objects in the ODF folder (#ODFFLDR) that are incomplete or in error, are deleted. An entry for each object that is deleted is made in the ODF Distribution Log.
3. ODF user profiles in the ODF folder (#ODFFLDR) that do not have a corresponding entry in the system userid security file, are deleted. An entry for each user profile that is deleted is made in the ODF distribution log.
4. The Object Distribution Facility/36 communications area is built. This communications area is used by ODF/36 tasks during execution.

ODFIPL

R36L012-0

The ODFIPL procedure has no parameters.

ODFLOAD Procedure

The ODFLOAD procedure copies the Object Distribution Facility/36 support into the system library (#LIBRARY). If Personal Services/36 is not currently on the system, then the ODFLOAD procedure will create a library named #OFCLIB and copy the communications and directory functions of Personal Services/36 into that library; these functions comprise the SNADS portion of Personal Services/36.

ODFLOAD copies Folder Management Services (FMS) support into the system library (#LIBRARY) if either Personal Services/36, Displaywrite/36, or IDDU is not currently on the system.

If the ICF Base feature code (6266 for 5360/5362, 6268 for 5363/5364) is not currently on the system, then the ODFLOAD procedure copies a subset of ICF BSCCL support into the system library (#LIBRARY).

If Object Distribution Facility/36 is not currently on the system, you must use the TOLIBR procedure to copy the diskette file ODF into #LIBRARY before running ODFLOAD. For detailed information about installing the Object Distribution Facility/36, see Chapter 2, "Setting Up ODF/36."

If #LIBRARY was backed up with Object Distribution Facility/36 on the system and then replaced before ODFLOAD is run, you do not have to copy the diskette file ODF using the TOLIBR procedure.

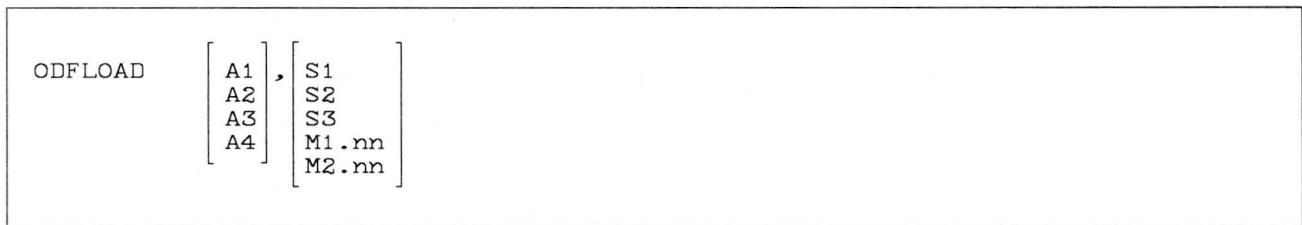

R36L018-1

A1, A2, A3, or A4 specifies the disk unit preference if the library #OFCLIB needs to be created. Specify the disk unit that you want searched first for available disk space. If not enough space is available on that unit, the other units (if they exist) are checked and the library #OFCLIB is placed on the least used disk unit. If no location is specified and the system has more than one disk unit, #OFCLIB is placed on the least used disk unit.

S1, S2, or S3 specifies the diskette slot containing the first diskette to be used. If no diskette position is specified, S1 is assumed.

M1.nn or M2.nn specifies the magazine location containing the first diskette to be used. M1 specifies the first magazine and M2 specifies the second magazine. nn is a decimal value from 01 to 10 that identifies the location of the diskette in the magazine. Specifying M1 is the same as specifying M1.01. Specifying M2 is the same as specifying M2.01.

ODFPROF Procedure

The ODFPROF procedure creates, updates, or deletes ODF/36 user profiles.

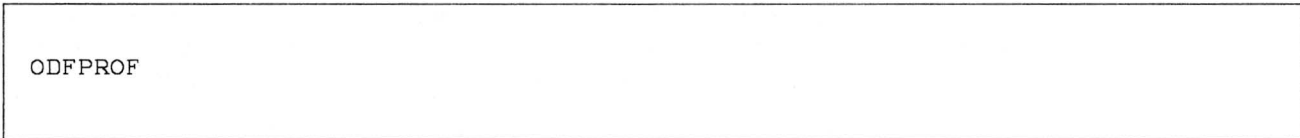

R36L021-1

The ODFPROF procedure has no parameters.

```

Work with ODF profiles
Type choice, press Enter.
Item                Choice  Possible choices
User Id . . . . . BECKY
Automatically submit jobs? . . . . . 2      1=YES 2=NO 3=MATCH
Arrived objects procedure name . . . . . _____
Library name . . . . . _____
Run arrival procedure? . . . . . 2      1=YES 2=NO
Automatically print spool files? . . . . . 2      1=YES 2=NO
Printer Id . . . . . SYSTEM
Forms . . . . . 0001
Copies . . . . . 001      1-255
Priority . . . . . 1      0-5
Object arrival message? . . . . . 2      1=YES 2=NO

Cmd2-Select user Id          Cmd3-Go back
Cmd4-Delete profile          Cmd7-End
** BECKY profile does not exist; press Enter to create          ODF-9756
    
```

Users can create their own ODF/36 profiles to control how Object Distribution Facility/36 processes objects that arrive for them. When an object arrives for a user on this system, Object Distribution Facility/36 reads that user's ODF/36 profile. If the user does not have an ODF/36 profile, then the ODF/36 system defaults will be read. See "ODFDFLT Procedure" on page 3-40 and "Object Distribution Facility/36 Defaults" on page 2-10 for information on the ODF/36 system defaults.

Note: The usage of this procedure is determined by the *Restrict ODFPROF procedure* parameter in the ODF/36 system profile. See "Object Distribution Facility/36 Defaults" on page 2-10.

User ID identifies the user for whom the profile is being defined.

Automatically submit jobs? defines how job streams received from other systems should be processed. There are three choices.

- | Number | Definition |
|----------------|--|
| 1 (Yes) | Specifies the job stream should be submitted automatically by Object Distribution Facility/36. |
| 2 (No) | Specifies the job stream should not be submitted; the job stream will be placed in the user's list of arrived objects. |

- 3 (Match)** Specifies the job stream is to be submitted if the sending and receiving user IDs match; the job stream will be placed in the user's list of arrived objects if the user IDs do not match.

See Chapter 4, "Automated and Unattended Operations" for information on processing job streams.

Arrived objects procedure name specifies the name of a user created procedure which will be evoked by Object Distribution Facility/36 when an object arrives for this user ID.

See Chapter 4, "Automated and Unattended Operations" for information on the arrived objects procedure.

Library name specifies the library where the *Arrived objects procedure* is to be found.

Run arrival procedure? There are two choices.

Number	Definition
1	<p>Specifies that the arrived objects procedure should always be evoked by Object Distribution Facility/36.</p> <p>Note: The following conditions must be met for the arrived objects procedure to be evoked:</p> <ol style="list-style-type: none"> 1. An arrived objects procedure and library name must be specified in the ODF/36 profile. 2. The specified arrived objects procedure must be found in the specified library. <p>See Chapter 4, "Automated and Unattended Operations" for information on the arrived objects procedure.</p>
2	<p>Specifies that the arrived objects procedure should only be evoked by Object Distribution Facility/36 if the user ID is not signed on.</p>

Automatically print spool files? There are two choices.

Number	Definition
1 (Yes)	<p>Specifies that spooled print file objects are to be automatically printed by Object Distribution Facility/36 when they arrive.</p>
2 (No)	<p>Specifies that spooled print file objects should not be printed automatically. The spooled print file will be placed in the user's list of arrived objects.</p>

See Chapter 4, "Automated and Unattended Operations" for information on processing spooled print files.

Printer id defines which printer is to be used for automatically printing spooled print files.

Forms defines the forms number to be used for automatically printing spooled print files.

Copies defines the number of copies to be printed for automatically printing spooled print files.

Priority defines the priority of spooled output for automatically printing spooled print files. The priority can be any decimal number from 5 through 0. The system prints spool file entries with higher priority numbers before jobs with lower priority numbers. For example, all printed output with a priority of 5 is printed before any other spool file entries. Spool file entries with the same priority are

printed in the order that they were placed on the spool file. Priority 1 entries are the last entries printed by the system.

Priority 0 entries are placed on the spool file with a priority of 1 and are held. These entries are not printed until a RELEASE control command is entered.

Object Arrival Message? defines if Object Distribution Facility/36 should send an *Object has arrived* message each time an object arrives for this user ID.

Number	Definition
1	Specifies that a message should be sent each time an object arrives for this user ID.
2	Specifies that a message should not be sent.

Users may create, update, and delete their ODF/36 profile.

A security officer can work with the ODF/36 profile for any users except another security officer or a master security officer. A master security officer can work with the ODF/36 profile for any user.

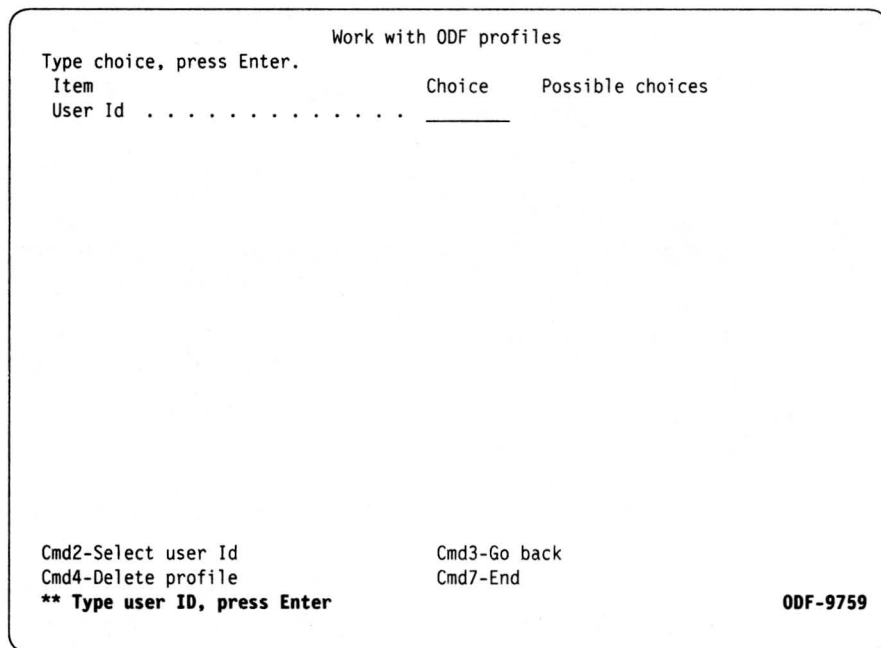

Figure 3-39. ODF/36 user profiles selection display

OFCCANCL

ODFSTART Procedure

The ODFSTART procedure starts the Object Distribution Facility/36 background tasks.

ODFSTART can be used after the ODFCANCL procedure has run, or the system has been IPLed.

ODFSTART

R36L019-0

The ODFSTART procedure has no parameters.

OFCCANCL Procedure

The OFCCANCL procedure stops Personal Services/36 (SNADS) background tasks.

For more information about the OFCCANCL procedure, see the manual *Administering Personal Services/36 in the Office*.

OFCCANCL

R36L026-0

The OFCCANCL procedure has no parameters.

OFCCOMM Procedure

The OFCCOMM procedure allows you to maintain Personal Services/36 (SNADS) communications definitions. Personal Services/36 (SNADS) communications definitions include queue definitions, remote destination definitions, and communication routes.

Note: The OFCCOMM procedure should not be used when communications is active.

OFCCOMM

```
[
  APPC
  QUEUES
  RMTDEST
  ROUTES
]
```

R36L027-0

APPC specifies System/36 communications definitions using APPC are to be maintained.

QUEUES specifies communications queue definitions are to be maintained.

RMTDEST specifies remote destinations are to be maintained.

ROUTES specifies communications routes are to be maintained.

OFCCTRL Procedure

The OFCCTRL procedure allows you to start Personal Services/36 (SNADS) background tasks, and control any distribution queues.

OFCCTRL	$\left\{ \begin{array}{l} \text{HOLD} \\ \text{RECOVER} \\ \text{RELEASE} \\ \text{RESUME} \\ \text{SEND} \end{array} \right\}$,	[remote location name]	,	[session group name]
---------	---	---	------------------------	---	----------------------

R36L055-0

HOLD Holds the specific queue defined by the remote location and session group.

RECOVER This parameter is not used by Object Distribution Facility/36.

RELEASE Releases the specific queue defined by the remote location and session group name.

RESUME Resumes Personal Services/36 (SNADS) processing as required after using OFCCANCL or after an IPL. If this procedure is called from the user IPL procedure, and the IPL procedure also reorganizes Personal Services/36 files, the file reorganization step must occur first.

SEND Starts transmission of distribution entries in the specific queue defined by the remote location and session group name.

Remote location name The remote location name as defined when using the APPC, or APPN subsystems.

Session group name The session group name as defined when using the APPC, or APPN subsystems.

Note: The parameters to control distribution queues are only valid for SNADS queues. If specified for an RSCS queue definition the function is ignored.

OFCDFLT Procedure

The OFCDFLT procedure changes the default values used by Personal Services/36 (SNADS). If password security is active, a security officer can change system default values.

For more information about Personal Services/36 (SNADS), see the online information. To read the online information, do any of the following:

- Run the READINFO procedure. For Personal Services/36 (SNADS), specify:
READINFO #OFCDOC,#OFCFLDR
- Select option 11 from the Use Personal Services/36 (SNADS) menu
- Press the Help key from any Personal Services/36 (SNADS) display

OFCDFLT

[USER
OFFICE]

R36L028-0

USER this parameter is not used by Object Distribution Facility/36.

OFFICE specifies that you want to change system default values. You must be a security officer to change these values.

OFCDIR Procedure

The OFCDIR procedure selects different ways of looking at the directory.

For more information about Personal Services/36 (SNADS), see the online information. To read the online information, do any of the following:

- Run the READINFO procedure. For Personal Services/36 (SNADS), specify:
READINFO #OFCDOC,#OFCFLDR
- Select option 11 from the Use Personal Services/36 (SNADS) menu
- Press the Help key from any Personal Services/36 (SNADS) display

OFCDIR	[USER GROUP NAME PHONE]
--------	--

R36L029-0

- USER** specifies that you want to look at directory entries in alphabetic order by user identification. If no parameter is specified, USER is assumed.
- GROUP** specifies that you want to look at directory entries for the members of a list. You cannot add or delete names in the directory or list.
- NAME** specifies that you want to look at entries in the directory in alphabetic order by name. You can add, change, or delete entries in the directory.
- PHONE** this parameter is not used by Object Distribution Facility/36.

OFCGRP Procedure

The OFCGRP procedure allows you to work with a user list.

For more information about Personal Services/36 (SNADS), see the online information. To read the online information, do any of the following:

- Run the READINFO procedure. For Personal Services/36 (SNADS), specify:
READINFO #OFCDOC,#OFCFLDR
- Select option 11 from the Use Personal Services/36 (SNADS) menu
- Press the Help key from any Personal Services/36 (SNADS) display

OFCGRP

R36L030-0

The OFCGRP procedure has no parameters.

OFCINSTL Procedure

The OFCINSTL procedure installs Personal Services/36 (SNADS) files on the system.

For more information about Personal Services/36 (SNADS), see the online information. To read the online information, do any of the following:

- Run the READINFO procedure. For Personal Services/36 (SNADS), specify:
READINFO #OFCDOC,#OFCFLDR
- Select option 11 from the Use Personal Services/36 (SNADS) menu
- Press the Help key from any Personal Services/36 (SNADS) display

See “Initializing Personal Services/36 (SNADS)” on page 2-13 for detailed information.

OFCINSTL

R36L031-0

The OFCINSTL procedure has no parameters.

OFCMAINT

OFCMAINT Procedure

The OFCMAINT procedure maintains SNADS information. You can maintain communications queue definitions, or communications routes.

The OFCMAINT procedure should be run when no one else is using Personal Services/36 (SNADS).

For more information about Personal Services/36 (SNADS), see the online information. To read the online information, do any of the following:

- Run the READINFO procedure. For Personal Services/36 (SNADS), specify:
READINFO #OFCDOC,#OFCFLDR
- Select option 11 from the Use Personal Services/36 (SNADS) menu
- Press the Help key from any Personal Services/36 (SNADS) display

OFCMAINT	[QUEUES ROUTES MAILFLDR REPORT]
----------	--

R36L032-0

QUEUES specifies that you want to look at each communications queue definition and add or select entries to be updated or deleted.

ROUTES specifies that you want to look at each communications route and add or select entries to be updated or deleted.

MAILFLDR this parameter is not used by Object Distribution Facility/36.

REPORT this parameter is not used by Object Distribution Facility/36.

OFCQ Procedure

The OFCQ procedure controls the SNADS communications queues.

For more information about Personal Services/36 (SNADS), see the online information. To read the online information:

- Run the READINFO procedure. For Personal Services/36 (SNADS), specify:
READINFO #OFCDOC,#OFCFLDR
- Select option 11 from the Use Personal Services/36 (SNADS) menu
- Press the Help key from any Personal Services/36 (SNADS) display

OFCQ [<u>ACTIVITY</u>] , [<u>START</u>] [<u>COMM</u>] [<u>STOP</u>]
--

R36L033-0

ACTIVITY this parameter is not used by Object Distribution Facility/36.

COMM specifies that you want to control the communications queues.

START this parameter is not used by Object Distribution Facility/36.

STOP this parameter is not used by Object Distribution Facility/36.

OFCQ COMM

CONTROL COMMUNICATIONS QUEUES					A11
Type options beside entries below, press Enter					
Options: 1=Hold 2=Release 3=Display entries 4=Start transmission					
OPTION	REMOTE LOCATION	SESSION GROUP	HELD	SENDING	
-	ADEL	HIGH	NO	NO	
-	ADEL	NORMAL	NO	NO	
-	ADEL	STATUS	NO	NO	
-	PERTVM		NO	NO	
-	SYDN	COMMON	NO	NO	
Cmd3=Go back Cmd7=Quit Roll=Page					

Note: A queue definition is required if communicating with RSCS; however, the queue is only used to enable Personal Services/36 (SNADS) to route objects from other SNADS systems to the next RSCS system. These objects are placed in the ODF folder (#ODFFLDR), and the LISTRSCS procedure should be used to work with entries on an RSCS queue. The Personal Services/36 (SNADS) queue for RSCS will never show entries on the queue. The options Hold, Release, Display or Start are ignored.

- 1 = **Hold** will hold the queue and all entries in the queue. Any entries added are also held.
- 2 = **Release** will release a queue that was previously held.
- 3 = **Display entries** will display the list of entries for the selected queue. From this display, individual entries can be held, released or deleted. See "Display Queue Entries"
- 4 = **Start transmission** will immediately attempt to send entries for selected queues. If the queue has been held it is released.

The column headings are:

REMOTE LOCATION, SESSION GROUP are the remote location, session group pairs that define the queues. These match those defined in the APPC or APPN subsystem.

An RSCS remote location name must be defined for entries coming from SNADS going to RSCS. There should be one entry for each RSCS link. The *remote location* must be named the same as the RSCS system name. The *session group* must be blank.

Note: A queue definition is required if communicating with RSCS; however, the queue is only used to enable Personal Services/36 (SNADS) to route objects from other SNADS systems to the next RSCS system. These objects are placed in the ODF folder (#ODFFLDR), and the LISTRSCS procedure should be used to work with entries on an RSCS queue. The Personal Services/36 (SNADS) queue for RSCS will never show entries on the queue. The options Hold, Release, Display or Start are ignored.

Display Queue Entries

DISPLAY QUEUE ENTRIES Top

Remote Location ADEL
 Session Group NORMAL
 Send Length 1

Type options beside entries below, press Enter
 Options: 1=Hold 2=Release 4=Delete

OPTION	SENDER SYSTEM	SENDER USER ID	DATE	TIME	HELD	PRIORITY	SENDING
-		PAUL	07/07/88	21:13:30	NO	2	NO
-		PAUL	07/07/88	21:58:19	NO	2	NO
-		PAUL	07/07/88	21:58:56	NO	2	NO
-		JEFF	08/07/88	00:48:03	NO	2	NO
-		JEFF	09/07/88	21:47:01	NO	2	NO
-		PAUL	10/07/88	11:10:21	NO	2	NO
-		PAUL	10/07/88	11:10:46	NO	2	NO
-		JEFF	10/07/88	12:37:57	NO	2	NO
-		JEFF	10/07/88	12:38:23	NO	2	NO
-		JEFF	10/07/88	15:53:15	NO	2	NO
-		JEFF	10/07/88	15:53:41	NO	2	NO

Cmd3=Go back Cmd7=Quit Roll=Page

- 1 = **Hold** will hold a queue entry.
- 2 = **Release** will release a queue entry that was previously held.
- 4 = **Delete entries** will delete an entry from the queue.
 A confirmation display for delete options is displayed.

RECVFILE Procedure

This procedure is used for receiving arrived objects into a file in batch.

```
RECVFILE object name 1 , object name 2 , object type , sequence number ,
file name , [REPLACE]
```

R36L007-4

object name 1 is the first part of the name of an object which has arrived.

object name 2 is the second part of the name of an object which has arrived.

object type is the 6-character object type of an object which has arrived.

sequence number is a 4-digit number assigned to an object by ODF/36 when it arrives. The number starts at 0001, increases to 9999 and then starts over at 0001. It is used to help uniquely identify arrived objects.

file name is the name of a disk file where the object is to be received. A file will be created if one does not exist.

REPLACE specifies that if a file of the same name already exists on disk, then it is to be replaced. If **REPLACE** is not specified, then an existing disk file of the same name should not be replaced.

Note: If the system is configured for date differentiated files, then specifying **REPLACE** will result in the file being replaced if a file of the same name and creation date exists, or in a date differentiated file being created if a file of the same name but a different creation date exists.

If **REPLACE** is not specified, an error occurs if a file of the same name and creation date exists, or in a date differentiated file being created if a file of the same name but a different creation date exists.

RECVFLDR

RECVFLDR Procedure

This procedure is used for receiving arrived objects into a folder in batch.

```
RECVFLDR object name 1 , object name 2 , object type , sequence number ,  
  
folder name , [REPLACE]
```

R36L046-0

object name 1 is the first part of the name of an object which has arrived.

object name 2 is the second part of the name of an object which has arrived.

object type is the 6-character object type of an object which has arrived.

sequence number is a 4-digit number assigned to to an object by ODF/36 when it arrives. The number starts at 0001, increases to 9999 and then starts over at 0001. It is used to help uniquely identify arrived objects.

folder name is the name of a folder where the object is to be received. A folder will be created if one does not exist.

REPLACE specifies that if a folder of the same name already exists on disk, then it is to be replaced. If **REPLACE** is not specified, then an existing folder of the same name should not be replaced.

RECVLIBR Procedure

This procedure is used for receiving arrived objects into a library in batch.

If the object type is DATA or JOB, then a member name and member type can be specified for the receiving library. If the object type is LIBR or PTF, then only the library name can be specified, as the object contains directory information for the member(s) that comprise the object, and this directory information is used to re-create the member name(s) and member type(s). See "SENDLIBR Procedure" on page 3-67 for information on the format of objects that are library members.

```
RECVLIBR object name 1 , object name 2 , object type , sequence number ,
```

```
library name , [ member name , { SOURCE
                        (S)
                        PROC
                        (P)
                    } ]
```

R36L034-1

object name 1 is the first part of the name of an object which has arrived.

object name 2 is the second part of the name of an object which has arrived.

object type is the 6-character object type of an object which has arrived.

sequence number is a 4-digit number assigned to an object by ODF/36 when it arrives. The number starts at 0001, increases to 9999 and then starts over at 0001. It is used to help uniquely identify arrived objects.

library name is the name of the library where the object is to be received, the library must already exist on the system.

member name is the name of the member to be created for the type DATA or JOB object.

SOURCE or S specifies that a library source member is to be created.

PROC or P specifies that a library procedure member is to be created.

RECVPRT Procedure

This procedure is used for printing and deleting arrived objects in batch.

```
RECVPRT object name 1 , object name 2 , object type , sequence number ,
```

```

{ printer id } , formsno , copies , priority
SYSTEM

```

R36L035-1

object name 1 is the first part of the name of an object which has arrived.

object name 2 is the second part of the name of an object which has arrived.

object type is the 6-character object type of an object which has arrived.

sequence number is a 4-digit number assigned to to an object by ODF/36 when it arrives. The number starts at 0001, increases to 9999 and then starts over at 0001. It is used to help uniquely identify arrived objects.

SYSTEM or printer id specifies which printer on the system is to be used for the printing of this spooled print file object.

formsno specifies the forms number to be used for printed output.

copies specifies the number of copies to be printed.

priority specifies the priority for printed output.

The system prints spool file entries with higher priority numbers before jobs with lower priority numbers. Spool file entries with the same priority are printed in the order that they were placed on the spool file. Priority 0 entries are placed on the spool file with a priority of 1 but are held. These entries are not printed until a RELEASE control command is entered.

SENDFILE Procedure

The SENDFILE procedure sends a file or a file group to another user or list of users.

When a file group is sent, one distribution is sent for each member of the file group. If a file group has 10 members, 10 different distributions will be sent.

File groups are defined by file names that contain a period. The characters preceding the period identify the file group, and the characters following the period identify the file within the group. As for all file names, the maximum number of characters is eight including the period. Files with names that do not contain a period are not part of a file group. Examples of names of files within a file group are:

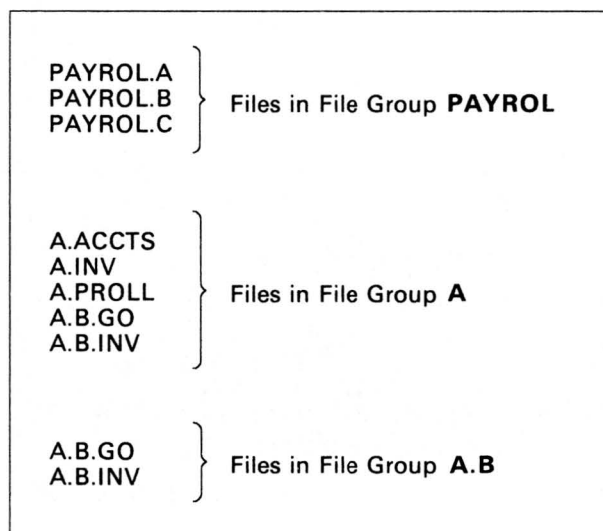

S9020222-0

SENDFILE

The SENDFILE procedure loads and runs module \$NTSNO.

To send a single file to another user or list of users:

```
SENDFILE    file name , [ mmddyymmddyy , [ S36FMT ] , { userid ,  
                        [ ddmmyy          DATA ] , { user id , address  
                        [ yymmdd          PUNCH ] , { distribution list ,  
  
[ priority ] , [ rscs distribution ] , [ rscs class ] , [ NOACK  
  50          code                   A                   ACK  
]
```

R36L000-4

To send a group of files to another user or list of users:

```
SENDFILE    ALL , file group , [ S36FMT ] , { user id ,  
                                [ DATA ] , { user id , address  
                                [ PUNCH ] , { distribution list ,  
  
[ priority ] , [ rscs distribution ] , [ rscs class ] , [ NOACK  
  50          code                   A                   ACK  
]
```

R36L001-5

file name specifies the name of one disk file to be sent.

ALL specifies a file group is to be sent. When ALL is specified as the first parameter, a file group must be specified as the second parameter. All members of that file group are sent.

file group specifies the name of the file group to be sent. The period (.) that indicates a file group name must not be specified. For example, to send all the files belonging to a file group that includes PAYROL.A, PAYROL.B, and PAYROL.C, you would enter PAYROL for this parameter.

mmddyymmddyy, ddmmyy, or yymmdd specifies the creation date of the disk file. The date must be in the same format as the session date; use the STATUS SESSION control command to determine the date format. If the creation date is not specified and more than one file exists with the specified name, the most recent file is sent.

S36FMT specifies that the files are to be sent in an internal format that preserves the S/36 attributes of the file. This allows a file to maintain its System/36 formatting when being sent to another System/36. For example, an indexed file with noncontiguous keys sent in S36FMT has these attributes restored when received on another S/36. A file sent in this format only has meaning to another S/36, or the System/36 Environment on the AS/400 system.

DATA specifies that the files are to be sent as consecutive record images without regard to index (if one exists). No S/36 file attributes are preserved.

This format would be used when sending to a system other than another S/36, or the System/36 Environment on the AS/400 system. See Chapter 7, "Improving System Performance" for information on the performance implications of S36FMT and DATA.

PUNCH specifies that the files are to be sent as consecutive record images without regard to index (if one exists). No S/36 file attributes are preserved. The files are sent in S/370 PUNCH, or 80 column card, format. Records are truncated to 80 bytes.

This format should only be used when sending to a S/370 application that requires the data to be in PUNCH, or 80 column card, format.

user id identifies a user on your system to whom the file or files are to be sent. The user ID is 1 to 8 characters and identifies a specific user to the system.

user id, address identifies a user on another system to whom the file or files are to be sent. The user ID together with the system address identifies a specific user on another system.

distribution list can identify both users on the local system and users on one or more other systems.

Lists make it easier to send objects to many people. They allow you to do such things as create a common distribution list for a group of people.

Note: All user IDs and distribution lists to whom you want to send information must be included in the directory file. See "Creating Directory Files" on page 2-13.

priority specifies the priority used for queueing retransmission at any systems through which the distribution is routed on the way to its destination. Valid priorities are 01 (highest) through 99 (lowest). The default priority is 50.

In a SNADS network, any number from 1 to 49 specifies that the object is sent on the SNADS high priority queue, any number from 50 to 99 specifies that the object is sent on the SNADS low priority queue.

When the object sent is routed through an RSCS network, the priority value as originally specified is passed to RSCS and is used in the RSCS queueing algorithm for each RSCS link the object is routed through.

rscs distribution code specifies the distribution code for objects received on a S/370.

rscs class specifies the class of the distribution. This information is required for certain functions (such as job submission for correct output device selection) at VM or MVS systems.

ACK specifies that a message confirming that the object has arrived at its destination(s) is sent back to this user ID.

NOACK specifies that no confirmation is required.

SENDFILE

Object Naming Conventions

The two-part object name created by the SENDFILE procedure is:

Object name part 1 The name of the file

Object name part 2 Myymmdd, where *yymmdd* is the creation date of the file.

For example, file FILE1 with a creation date of October 18, 1988, will be known as FILE1 M881018.

Example 1

To send file EXAMPLE1 to local user ODFADMIN in S36FMT.

```
SENDFILE EXAMPLE1,,ODFADMIN
```

Example 2

To send file EXAMPLE1 to remote RSCS user BECKY MELBVMA in DATA format, with file class B and distribution code BECKY.

```
SENDFILE EXAMPLE1,,DATA,BECKY,MELBVMA,,BECKY,B
```

Example 3

To send ALL files in the file group name PAYROL to a list of users specified in the distribution list DEPT007 in S36FMT.

```
SENDFILE ALL,PAYROL,,DEPT007
```

SENDFLDR Procedure

This procedure sends a folder to another user or list of users.

The SENDFLDR procedure loads and runs the program module \$NTSNO.

```

SENDFLDR  folder name , { user id,
                        user id, address
                        distribution list, } , [ priority
                                                50 ] ,
          [ rscs distribution
            code ] , [ rscs class
                      A ] , [ NOACK
                             ACK ]

```

R36L003-4

folder name specifies the folder to be sent.

user id identifies a user on your system to whom the folder is to be sent. The user ID is 1 to 8 characters and identifies a specific user to the system.

user id, address identifies a user on another system to whom the folder is to be sent. The user ID together with the system address identifies a specific user on another system.

distribution list can identify both users on the local system and users on one or more other systems.

Lists make it easier to send objects to many people. They allow you to do such things as create a common distribution list for a group of people.

Note: All user IDs and distribution lists to whom you want to send information must be included in the directory file. See "Creating Directory Files" on page 2-13.

priority specifies the priority used for queueing retransmission at any systems through which the distribution is routed on the way to its destination. Valid priorities are 01 (highest) through 99 (lowest). The default priority is 50.

In a SNADS network, any number from 1 to 49 specifies that the object is sent on the SNADS high priority queue, any number from 50 to 99 specifies that the object is sent on the SNADS low priority queue.

When the object sent is routed through an RSCS network, the priority value as originally specified is passed to RSCS and is used in the RSCS queueing algorithm for each RSCS link the object is routed through.

rscs distribution code specifies the distribution code for objects received on a S/370.

rscs class specifies the class of the distribution. This information is required for certain functions (such as job submission for correct output device selection) at VM or MVS systems.

ACK specifies that a message confirming that the object has arrived at its destination(s) is sent back to this user ID.

NOACK specifies that no confirmation is required.

SENDFLDR

Object Naming Conventions

The two-part object name created by the SENDFLDR procedure is:

Object name part 1 The name of the folder

Object name part 2 FOLDER

For example, folder TXTJDELU will be known as **TXTJDELU FOLDER**

SENDJOB Procedure

This procedure sends a job stream to another user or list of users.

The SENDJOB procedure loads and runs the program module \$NTSNO.

```

SENDJOB member name , { SOURCE
                       (S)
                       PROC
                       (P) } , [ library name ] , [ DATA
                                                PUNCH ] , { user id,
                                                           user id, address
                                                           distribution list, }

```



```

[ priority
  50 ] , [ rscs distribution
          code ] , [ rscs class
                   A ] , [ NOACK
                          ACK ]

```

R36L005-6

member name specifies the library member to be sent.

SOURCE or S specifies the library member is a source member.

PROC or P specifies the library member is a procedure.

library name specifies the library where the member resides. If this parameter is not entered, then the current library is assumed.

DATA specifies that the library member is sent as consecutive record images.

PUNCH specifies that the library member is sent as consecutive record images. The library member is sent in S/370 PUNCH, or 80 column card, format. Records are truncated to 80 bytes.

This format should only be used when sending to a S/370 application that requires the data to be in PUNCH, or 80 column card, format. For example, job submission to VM Batch, or MVS/JES.

user id identifies a user on your system to whom the job stream is to be sent. The user ID is 1 to 8 characters and identifies a specific user to the system.

user id, address identifies a user on another system to whom the job stream is to be sent. The user ID together with the system address identifies a specific user on another system.

distribution list can identify both users on the local system and users on one or more other systems.

Lists make it easier to send objects to many people. They allow you to do such things as create a common distribution list for a group of people.

Note: All user IDs and distribution lists to whom you want to send information must be included in the directory file. See "Creating Directory Files" on page 2-13.

SENDJOB

priority specifies the priority used for queueing retransmission at any systems through which the distribution is routed on the way to its destination. Valid priorities are 01 (highest) through 99 (lowest). The default priority is 50.

In a SNADS network, any number from 1 to 49 specifies that the object is sent on the SNADS high priority queue, any number from 50 to 99 specifies that the object is sent on the SNADS low priority queue.

When the object sent is routed through an RSCS network, the priority value as originally specified is passed to RSCS and is used in the RSCS queueing algorithm for each RSCS link the object is routed through.

rscs distribution code specifies the distribution code for objects received on a S/370.

rscs class specifies the class of the distribution. This information is required for certain functions (such as job submission for correct output device selection) at VM or MVS systems.

ACK specifies that a message confirming that the object has arrived at its destination(s) is sent back to this user ID.

NOACK specifies that no confirmation is required.

Object Naming Conventions

The two-part object name created by the SENDJOB procedure is:

Object name part 1 The name of the library which the job resides

Object name part 2 The name of the library member which contains the job stream

For example, member JOB01 in library JOBLIB will be known as JOBLIB JOB1.

SENDLIBR Procedure

The SENDLIBR procedure sends one or more library members to another user or list of users.

Library members can be sent in S36FMT or DATA. If the members are sent in S36FMT, a single distribution consisting of all the members specified is sent. If the members are sent in DATA, one distribution is sent for each member specified.

The SENDLIBR procedure loads and runs the program module \$NTSNO.

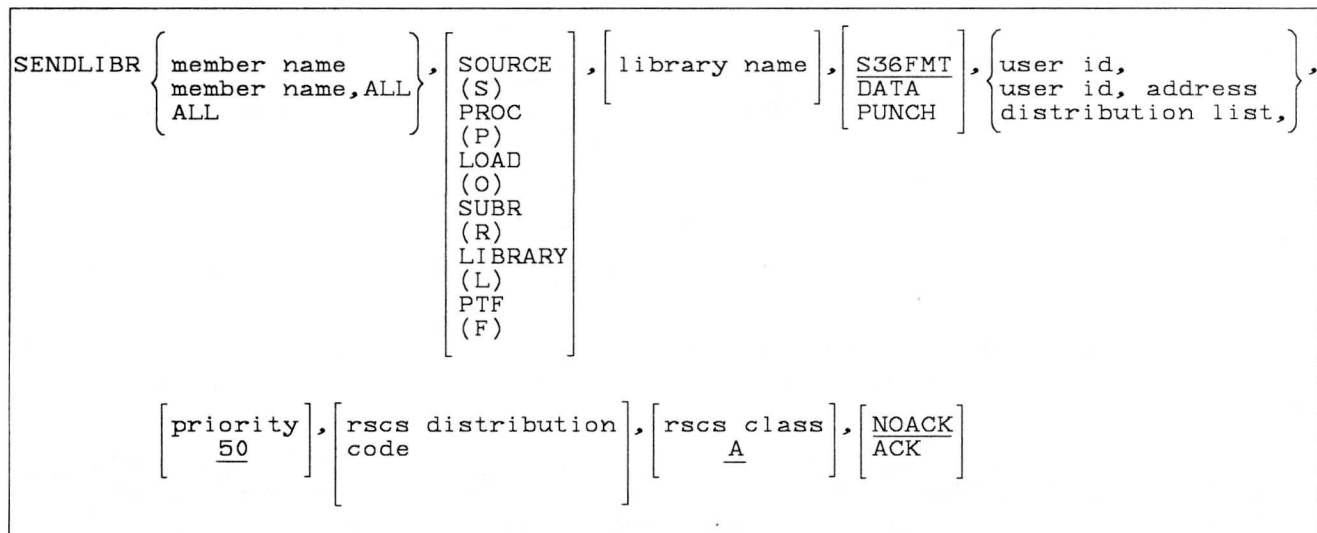

R36L002-4

member name specifies the library member to be sent.

member name,ALL specifies that one or more library members with the names beginning with *member name* are to be sent. The name can be up to 7 characters long. For example, **PAY,ALL** specifies all library members having names that begin with **PAY** are to be sent, such as **PAYROLL**, **PAYCHECK**, or **PAYRUN**.

ALL specifies that all members in the library are to be sent.

SOURCE or **S** specifies that only source members are to be sent. If a parameter is not specified, **SOURCE** is assumed.

PROC or **P** specifies that only procedure members are to be sent.

LOAD or **O** specifies that only load members are to be sent.

SUBR or **R** specifies that only subroutine members are to be sent.

PTF or **F** specifies that only members having a PTF applied are to be sent.

Note: Microcode PTFs are not sent.

If sending in **DATA**, then only source and procedure members having a PTF applied are sent.

LIBRARY or **L** specifies that all library members of all types (**SOURCE**, **PROC**, **LOAD**, **SUBR**, and **PTF**) are to be sent.

library name specifies the library containing one or more library members to be sent. If the library name is not specified, the current library is assumed.

Note: If sending in **DATA**, then only source and procedure members are sent.

S36FMT specifies that the library members are to be sent in an internal format that preserves the S/36 attributes of the library members. Library members sent in this format only have meaning to another S/36, or the AS/400 System/36 Environment.

When sending in S36FMT, all library members selected are packaged and sent as one distribution.

DATA specifies that each library member is sent as consecutive record images. Only source and procedure members are sent. No S/36 attributes are preserved.

When sending in DATA, each library member selected is sent as a separate distribution.

PUNCH specifies that each library member is sent as consecutive record images. Only source and procedure members are sent. No S/36 attributes are preserved. The library members are sent in S/370 PUNCH, or 80 column card, format. Records are truncated to 80 bytes.

This format should only be used when sending to a S/370 application that requires the data to be in PUNCH, or 80 column card, format.

When sending in PUNCH, each library member selected is sent as a separate distribution.

user id identifies a user on your system to whom the library member or library members are to be sent. The user ID is 1 to 8 characters and identifies a specific user to the system.

user id, address identifies a user on another system to whom the library member or library members are to be sent. The user ID together with the system address identifies a specific user on another system.

distribution list can identify both users on the local system and users on one or more other systems.

Lists make it easier to send objects to many people. They allow you to do such things as create a common distribution list for a group of people.

Note: All user IDs and distribution lists to whom you want to send information must be included in the directory file. See "Creating Directory Files" on page 2-13.

priority specifies the priority used for queueing retransmission at any systems through which the distribution is routed on the way to its destination. Valid priorities are 01 (highest) through 99 (lowest). The default priority is 50.

In a SNADS network, any number from 1 to 49 specifies that the object is sent on the SNADS high priority queue, any number from 50 to 99 specifies that the object is sent on the SNADS low priority queue.

When the object sent is routed through an RSCS network, the priority value as originally specified is passed to RSCS and is used in the RSCS queueing algorithm for each RSCS link the object is routed through.

rscs distribution code specifies the distribution code for objects received on a S/370.

rscs class specifies the class of the distribution. This information is required for certain functions (such as job submission for correct output device selection) at VM or MVS systems.

ACK specifies that a message confirming that the object has arrived at its destination(s) is sent back to this user ID.

NOACK specifies that no confirmation is required.

Object Naming Conventions

The two-part object name created by the SENDLIBR procedure is:

Object name part 1 The name of the library from which the member(s) are being sent

Object name part 2 The name of the first library member to be selected

For example, all library members in library EXAMPLIB are being sent. The first member in this library is MBR01.

The object will be known as EXAMPLIB MBR01.

Example 1

To send source member MBR01 in library EXAMPLIB in DATA to a list of users specified in the distribution list DEPT007.

```
SENDLIBR MBR01,SOURCE,EXAMPLIB,DATA,DEPT007
```

Example 2

To send all procedure members which begin PRC in library PAYLIB in S36FMT to PAUL COLLS36.

```
SENDLIBR PRC,ALL,PROC,PAYLIB,S36FMT,PAUL,COLLS36
```

Example 3

To send all members in the system library which have a PTF applied to ODFADMIN MELBS36B.

```
SENDLIBR ALL,PTF,#LIBRARY,S36FMT,ODFADMIN,MELBS36B
```

SENDPRT

SENDPRT Procedure

This procedure sends one or more spool file entries from the spool file. Up to 255 entries can be sent at one time to another user or list of users. One distribution is sent for each spool file entry specified.

The SENDPRT procedure loads and runs the program module \$NTSNO.

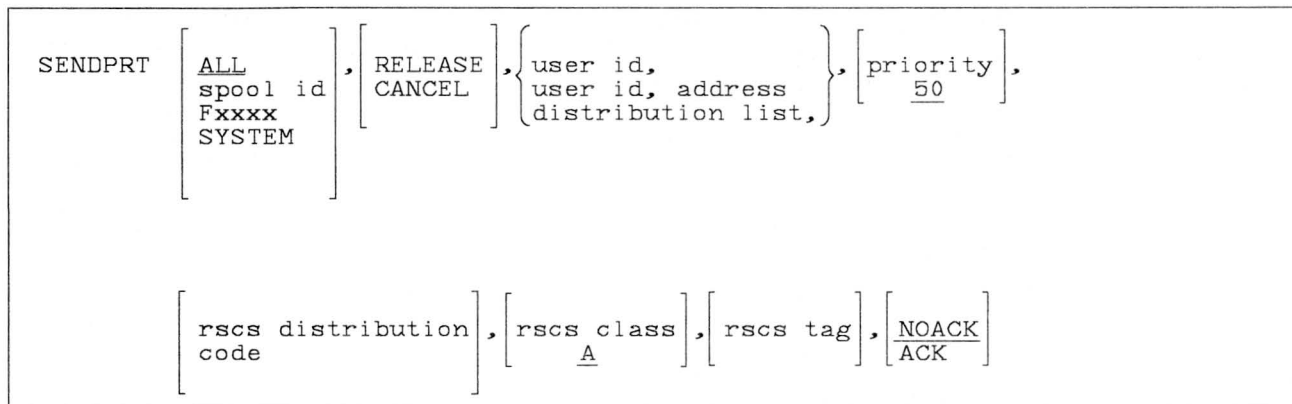

R36L004-3

ALL specifies that all spool files for this user are to be sent.

spool id specifies the 6-character spool file ID of the spool file to be sent.

Fxxxx specifies the forms number of one or more spool file entries to be sent. All spool files using the forms number entered will be sent except for entries currently being processed.

SYSTEM specifies that all spool file entries are to be sent.

RELEASE specifies that after the spool files have been sent, the spool files (on the originating system) are to be released for printing.

CANCEL specifies that after the spool files have been sent, the spool files (on the originating system) are not to be printed but are to be removed from the spool file.

If neither **RELEASE** nor **CANCEL** are specified, the spool file will remain in the spool queue.

user ID identifies a user on your system to whom the spool file(s) are to be sent.

The user ID is 1 to 8 characters and identifies a specific user to the system.

user ID, address identifies a user on another system to whom the spool file(s) are to be sent. The user ID together with the system address identifies a specific user on another system.

distribution list can identify both users on the local system and users on one or more other systems.

Lists make it easier to send objects to many people. They allow you to do such things as create a common distribution list for a group of people.

Note: All user IDs and distribution lists to whom you want to send information must be included in the directory file. See "Creating Directory Files" on page 2-13.

priority specifies the priority used for queuing retransmission at any systems through which the distribution is routed on the way to its destination. Valid priorities are 01 (highest) through 99 (lowest). The default priority is 50.

In a SNADS network, any number from 1 to 49 specifies that the object is sent on the SNADS high priority queue, any number from 50 to 99 specifies that the object is sent on the SNADS low priority queue.

When the object sent is routed through an RSCS network, the priority value as originally specified is passed to RSCS and is used in the RSCS queuing algorithm for each RSCS link the object is routed through.

rscs distribution code specifies the distribution code for objects received on a S/370.

rscs class specifies the class of the distribution. This information is required for certain functions (such as job submission for correct output device selection) at VM or MVS systems.

rscs tag is normally used to specify printer output control information which depends on the specific installation. Consult with your S/370 system administrator if you plan to have output on a S/370.

ACK specifies that a message confirming that the object has arrived at its destination(s) is sent back to this user ID.

NOACK specifies that no confirmation is required.

Object Naming Conventions

The two-part object name created by the SENDPRT procedure is:

Object name part 1 The name of the printer file for the spool file selected

Object name part 2 PRTF

For example, a spooled print file produced by the CATALOG procedure will be known as, \$SYSLIST PRTF.

Print Attributes

The following print attributes are preserved if the spooled print file is sent to a S/36, S/38, or the AS/400 system:

- Forms number
- Lines per inch
- Characters per inch
- Lines per page (forms length)
- Overflow line
- Forms width
- Number of copies
- Drawer
- Font
- Page rotation
- IGC

Return Codes

If the SENDPRT procedure is running from the job queue, or is evoked, then the following spool file errors will not result in a system message being issued. Instead, the job return code will be set to the message identification code for the error received.

SENDPRT

This allows a user procedure to test for these errors and take appropriate action, if any.

Notes:

1. The job return code is processed in a procedure by the ?CD? substitution expression.
2. Any message identification code in the range 8540 through 8950 will be set in the job return code. The following list represents the more common errors.
3. If running the SENDPRT procedure interactively, then all messages are issued as any other system error message.

8540 - No spool entries for user ID specified
8541 - Entry(s) not available now
8543 - Specified spool id does not exist
8546 - Invalid first parameter
8547 - User not authorized to use 'SYSTEM' parameter
8548 - User ID does not match SPnnnn specified
8549 - Print spooling not active
8552 - Tried to copy > 255 spool entries
8553 - Cannot copy an entry with zero pages
8739 - Spool is empty
8740 - No entry(s) for Fnnnn specified
8946 - Disk I/O error -- accessing spool file
8947 - Invalid forms number entered
8948 - Invalid spool id entered
8949 - Spool file format error
8950 - Invalid data in spool file entry

STOPRSCS Procedure

This procedure stops one or more RSCS communications links. When a specified RSCS system name is given, the RSCS link task for that system is terminated and the communications subsystem is disabled. Other ODF/36 activity is not stopped.

When ALL is entered, all the active RSCS link tasks are terminated.

The user of this procedure must have system operator authority or higher.

```

STOPRSCS { ALL
          RSCS system name }, [ RSCS system name ], [ RSCS system name ],
[ RSCS system name ], [ RSCS system name ], [ RSCS system name ], [ RSCS system name ],
[ RSCS system name ]

```

R36L036-1

ALL specifies that all RSCS activity on all lines are to be stopped.

RSCS system name specifies the name of the remote RSCS system to stop communications.

Up to 8 RSCS system names may be specified.

STRTRSCS

STRTRSCS Procedure

The STRTRSCS procedure starts one RSCS communications link.

This procedure will dynamically create a CNFIGICF line and subsystem member for communications with the RSCS system and will enable the subsystem. The created CNFIGICF members will be placed in library #ODFCNFG; this library will be created by this procedure if it does not exist.

The members in the #ODFCNFG library should not be altered or viewed using the CNFIGICF procedure.

The user of this procedure must have system operator authority or higher.

```
STRTRSCS    line number , RSCS system name
```

R36L020-2

```
                START COMMUNICATIONS WITH RSCS
Type choices, press Enter.
ITEM            CHOICE  POSSIBLE CHOICES
Line number     _      1-8
RSCS system name _____

Cmd3=Go back   Cmd7=End                                COPR IBM Corp. 1988
```

line number specifies the line number on which the RSCS link is to be started.

system name specifies the name of the remote RSCS system.

Chapter 4. Automated and Unattended Operations

This chapter discusses the facilities provided by Object Distribution Facility/36 that enable automated and unattended operations in a network of systems.

Before using the information in this chapter, the reader should already be familiar with Object Distribution Facility/36, and the information in Chapter 2, "Setting Up ODF/36" and Chapter 3, "Running ODF/36."

The examples in this chapter are not intended to cover all possible uses or implementations of Object Distribution Facility/36. They show how the Object Distribution Facility/36 functions can be used in some of the more obvious applications.

A knowledge of System/36 OCL and procedure programming is assumed.

Several of the parameters that can be specified in an ODF/36 profile control how objects are processed by Object Distribution Facility/36 when they arrive. These are:

- Automatically submit jobs?
- Automatically print spooled print files?
- Arrived objects procedure and library name
- Run arrival procedure?

These are processed as shown in Figure 4-1:

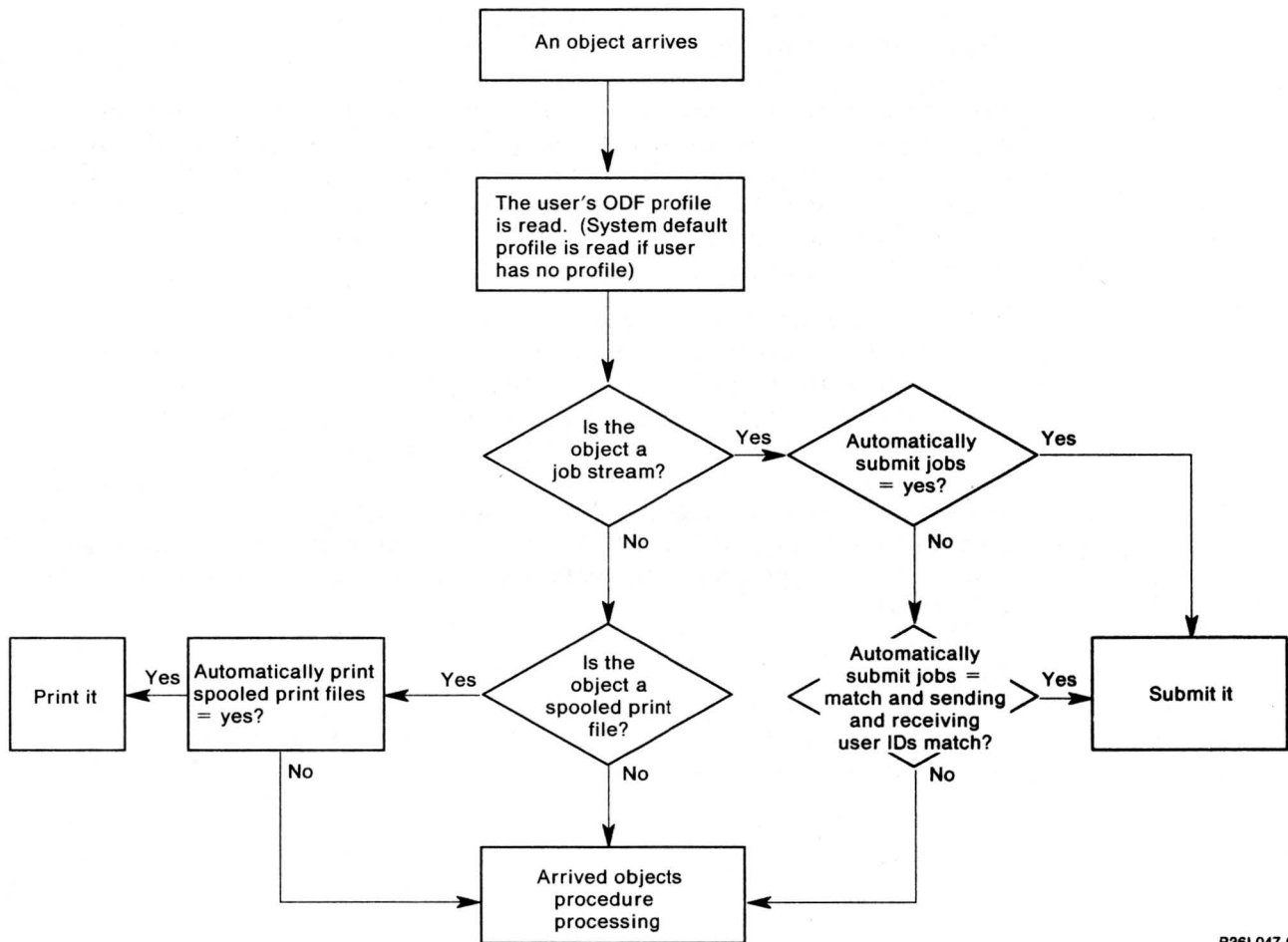

R36L047-0

Figure 4-1. Arrival Processing

Processing Job Streams

If a job stream arrives for a user and that user's ODF profile, or the ODF system default profile if the user has no ODF profile, indicates that the job stream should be automatically submitted, Object Distribution Facility/36 will receive the job stream into a temporary library procedure member and will then evoke the procedure member. The temporary procedure member will be deleted when the job stream completes (either normally or abnormally).

The job stream must contain System/36 OCL to be executed successfully. No checking of the contents of the job stream is made by Object Distribution Facility/36; it is evoked and will be processed by the system as any other evoked library procedure member.

The job stream can originate on any system, provided the contents of the job stream is System/36 OCL. For example, a System/38 user can create a source physical file member using the System/38 Source Entry Utility (SEU), the source physical file member will contain System/36 OCL, and then send the source physical file member as a job stream to a System/36 with the System/38 Submit Network Job (SBMNETJOB) command.

Note: A job stream cannot be sent from a S/370 system. This is because there is no way to identify the file from the S/370 as a job stream. That is, there is no SENDJOB or SBMNETJOB equivalent command. Sending job streams from S/370 to System/36 can be achieved indirectly by the arrived objects procedure. See "Arrived Objects Procedure" on page 4-8 for more information.

Sending job streams can be a powerful network management tool. A user at a central site system, can run jobs at the remote sites by sending job stream(s) from the central site. The job streams can optionally route their output back to the central site system.

Example 1

A user at a central site system wants information about the status of a remote site system. The following information will be collected and sent back to the central site system:

- The VTOC
- The history file
- The service log
- The product level data file
- The PTF log for the system library

The following procedure will show how system files can be sent to a central site system.

Note: This procedure is included in the EXAMPLES diskette file. See Appendix B, "The EXAMPLES Diskette File."

JOB00001:

```
* Lists and sends the following system files:
* The VTOC.
* The history file.
* The product level data file.
* The service log.
* The PTF log for the system library.
*
**
* Delete file ODF.VTOC if it exists,
* run CATALOG to list the VTOC to file ODF.VTOC
// IF DATAF1-ODF.VTOC DELETE ODF.VTOC,F1
CATALOG ALL,F1,,,NAME,,ODF.VTOC
**
* Delete file ODF.HIST if it exists,
* run HISTORY to list the history file to file ODF.HIST
// IF DATAF1-ODF.HIST DELETE ODF.HIST,F1
HISTORY COPYSYS,ALL,ALLWS,ALLENTS,ALLDAYS,,,ODF.HIST
**
* Delete file ODF.PLD if it exists,
* run LOGPLD to list the product level data file to file ODF.PLD
// IF DATAF1-ODF.PLD DELETE ODF.PLD,F1
LOGPLD USERCOPY,ODF.PLD,T
**
* Set the forms number to be INFO,
* run DUMP SERVLOG to list the system service log to dummy printer ID (P0)
PRINT ,,,,INFO
DUMP SERVLOG,P0
**
* Run DUMP PTF to list the #LIBRARY PTF log to dummy printer ID (P3)
DUMP PTF,P0,F1,#LIBRARY
**
* Send the file group ODF to the central site administrator ODFADMIN CENTSYS
SENDFILE ALL,ODF,,,ODFADMIN,CENTSYS
**
* Send the spooled print output (forms INFO) to the central site administrator
SENDPRT FINFO,CANCEL,ODFADMIN,CENTSYS
```

It is not required that a file group be used as in the previous example, however using a file group in this instance is a more efficient way of sending the data back to the central site. That is, only one invocation of the SENDFILE procedure is required to send all three files. However, the files could have been sent using three invocations of the SENDFILE procedure.

Sending Jobs from a Central Site System

As can be seen from the examples, there are many instances where job streams can be used for network management functions by a central site system. If a central site system will send similar jobs to the remote site systems on a regular basis, then consider using the following procedure for implementation:

1. An administrator library can be created at each remote site, for example, ADMINLIB. The administrator library will contain the jobs streams normally sent from the central site as library procedure members.

Note: The administrator library can also be centrally maintained and distributed using Object Distribution Facility/36.

Assume the administrator library contains three procedure members, JOB01, JOB02, and JOB03.

2. Instead of the central site administrator sending the JOB01 member from the central site to each remote site, a one line job stream can be sent. This would run the JOB01 procedure out of the administrator library at the remote system. For example:

Procedure: RUNJOB01

JOB01,ADMINLIB

This is a potentially much smaller object to distribute than the JOB01 procedure itself, and places less load on the network. Because the object is so small, it could be sent high priority (where it would be treated just like a message). If the central site administrator wishes to run JOB01 at all the remote sites, this represents a much more efficient way of doing so. Sending the one line job stream (RUNJOB01) high priority will mean that the JOB01 procedure will be executed at each remote site in a short time, whereas the output of the JOB01 procedure can be sent back to the central site at normal priority.

3. A distribution list would be created on the central site system. The distribution list would contain the user ID and address for the ODF/36 administrator signon at each remote system. For example, ODFADMIN SYS01, ODFADMIN SYS02, and so on.
4. The ODFADMIN user ID on each remote system would have an ODF/36 profile that sets the *Automatically submit jobs?* parameter to 3 (*Match*). This is for security reasons, as it is assumed that the ODFADMIN signon will be at least a security officer, and will ensure that only jobs received from user ID ODFADMIN will be submitted.
5. The following statement could be used to run the JOB01 procedure at all the remote sites:

```
SENDJOB RUNJOB01,PROC,ADMINLIB,,ALLADMIN,1
```

This sends procedure RUNJOB01 from library ADMINLIB to all users in the distribution list ALLADMIN at high priority in DATA.

Processing Spooled Print Files

There are three ways to process spooled print files that arrive through Object Distribution Facility/36:

1. Interactively, with the LISTOBJ procedure
2. Automatically, with the ODF/36 profile
3. In batch, with the RECVPRT procedure

Printing with LISTOBJ

This procedure processes a list of objects that have arrived for a user. Option 6, *Print and delete*, may be used to process spooled print files. The number of copies, and the forms number sent with the spooled print file will be displayed along with the printer ID, and print priority from the ODF profile. These values may be overridden before printing the object.

See "LISTOBJ Procedure" on page 3-12 for more information on the LISTOBJ procedure, and processing spooled print files with it.

Automatic Printing

If a spooled print file arrives for a user, and that user's ODF/36 profile (or the system default profile, if the user has no ODF/36 profile) indicates that spooled print files should be automatically printed, then Object Distribution Facility/36 will print the object using the print values specified in the ODF/36 profile. The values in the ODF/36 profile will always override the values sent with the spooled print file.

See "ODFPROF Procedure" on page 3-43 for information on working with ODF/36 profiles.

Printing with RECVPRT

A user procedure can use the RECVPRT procedure to print arrived spooled print file objects in batch.

```
RECVPRT object name 1 , object name 2 , object type , sequence number ,
```

```
{ printer id } , formsno , copies , priority  
SYSTEM
```

R36L035-1

Such a procedure would need to be in an arrived objects procedure, or after a job that used the LISTOBJ procedure to list the arrived objects to a disk file. This is required so that the first four parameters of the RECVPRT procedure can be specified to select the arrived spooled print file object for printing.

If the *forms number* and *copies* parameters are not specified, the values sent with the spooled print file will be used. If the *forms number* and *copies* parameters are specified, then they will override the values sent with the spooled print file.

See "RECVPRT Procedure" on page 3-58 for information on the RECVPRT procedure.

Arrived Objects Procedure

The arrived objects procedure is a user created procedure which is evoked by Object Distribution Facility/36 when an object arrives for a user and the following conditions are met:

- The user has an arrived objects procedure and library name specified in his ODF profile.
- The user is not signed on the system at the time the object arrives,
or
The user is signed on the system and has specified in his ODF/36 profile that the arrived objects procedure should always be run.
- The specified arrived objects procedure is found in the specified library.

Note: See "ODFPROF Procedure" on page 3-43 for information on how to specify the arrived objects procedure information in a user ODF/36 profile.

The arrived objects procedure is an open-ended interface for users to determine what processing should be performed when objects arrive for them. A typical example would be to automatically receive objects as they arrive; such an implementation could allow a central site system to distribute data to all the remote sites and have the data automatically applied (received) at each remote site.

Object Distribution Facility/36 passes parameters to the evoked arrived objects procedure, these parameters identify the object that has arrived and its origin.

Parameter	Description
1	Object name part 1
2	Object name part 2
3	Object type
4	Object sequence number
5	User ID of the sender
6	Address of the sender

Object Distribution Facility/36 provides four procedures which allow the processing of arrived objects from within a procedure. These are:

RECVFILE	Receive into a file.
RECVFLDR	Receive into a folder.
RECVLIBR	Receive into a library.
RECVPRT	Print a spooled print file.

These procedures can be used within an arrived objects procedure to automatically receive objects. This is easy to do because the first four parameters of each RECVxxxx procedure match the first four parameters passed to the arrived objects procedure.

Example 1

Unconditionally receive any object that arrives into a file. The file name will be the object name part 1, and if a file of that name exists it will be replaced.

Note: This procedure is included in the EXAMPLES diskette file. See Appendix B, "The EXAMPLES Diskette File."

ARRIV001:

- * Called by ODF/36 when an object arrives
- * Input parameters
- * P1 = Object name 1
- * P2 = Object name 2
- * P3 = Object type
- * P4 = Object sequence number
- * P5 = From user ID
- * P6 = From address
- *

RCVFILE ?1?,?2?,?3?,?4?,?1?,REPLACE

If object PAYFILE M881018 FILE 1234 arrives, it is received into a file called PAYFILE.

While this example is useful as a simple example of how an arrived objects procedure can be used to automatically receive objects, it would not be very useful in a real-life application.

Consider example 2:

Example 2

Note: This procedure is included in the EXAMPLES diskette file. See Appendix B, "The EXAMPLES Diskette File."

ARRIV002:

```

* Called by ODF/36 when an object arrives
* Input parameters
* P1 = Object name 1
* P2 = Object name 2
* P3 = Object type
* P4 = Object sequence number
* P5 = From user ID
* P6 = From address
*
* Tell the system to autorespond any error messages that may be
* generated by this procedure. In an unattended environment, this
* will prevent multiple copies of the arrival procedure potentially
* waiting on a response to a message at the system console.
*
* The system history file can be viewed to determine why this
* procedure may have failed
*
// NOHALT 4,JOB
**
* Branch to the appropriate part of this procedure according to the
* type of object that has arrived.
// GOTO ?3?
**
* Type = AIFILE or DATA or DUMP or SVF38 or SVF400 or TRACE or VDISK
// TAG AIFILE
// TAG DATA
// TAG DUMP
// TAG SVF38
// TAG SVF400
// TAG TRACE
// TAG VDISK
*
* Unconditionally receive into a file named after object name part 1
* and replace any existing file.
*
RECVFILE ?1?,?2?,?3?,?4?,?1?,REPLACE
// RETURN
**
* Type = FLDR
// TAG FLDR
*
* Unconditionally receive into a folder named after object name part 1
* and replace any existing folder.
*
RECVFLDR ?1?,?2?,?3?,?4?,?1?,REPLACE
// RETURN
**
* Type = LIBR or PTF
// TAG LIBR
// TAG PTF
*
* Unconditionally receive into a library named after object name part 1
* if a library of that name already exists.
* Note: the // IF DATAF1 only verifies that an entry in the system
* VTOC has the name of object name part 1. The entry could be for a
* file or a folder. All libraries have a load member called #PTFLOG,
* thus the // IF LOAD verifies that it is a library.
*
// IF DATAF1-?1? IF LOAD- '#PTFLOG,?1?' RECVLIBR ?1?,?2?,?3?,?4?,?1?

```

```

// RETURN
**
* Type = JOB or PRINT
// TAG JOB
// PRINT
*
* Ignore these objects. Leave them in the list of arrived objects.
*
// RETURN

```

Example 3

A S/370 cannot send a job stream to a System/36. This is because there is no way to identify the file from the S/370 as a job stream. That is, there is no SENDJOB equivalent command.

Sending job streams from S/370 to System/36 can be achieved indirectly with a dummy user ID and an arrived objects procedure, as follows:

1. Create a dummy user ID. For example, JOB.
2. Create an ODF/36 profile for user ID JOB and specify:
 - Automatically submit jobs = 1 (yes)
 - Arrived objects procedure = ARRIV003
 - Library name = SUBMJOB

Note: The procedure name and library name are examples only.

Note: This procedure is included in the EXAMPLES diskette file. See Appendix B, "The EXAMPLES Diskette File."

ARRIV003:

```

* Called by ODF/36 when an object arrives
* Input parameters
* P1 = Object name 1
* P2 = Object name 2
* P3 = Object type
* P4 = Object sequence number
* P5 = From user ID
* P6 = From address
*
* If the object type is not DATA then ignore it.
// IFF ?3?='DATA ' RETURN
**
* Receive the object into library SUBMJOB as a procedure member,
* the member name will be object name part 2.
RECVLIBR ?1?,?2?,?3?,?4?,SUBMJOB,?2?,P
**
** AA
**
* Submit the procedure member to the job queue.
// JOBQ 3,SUBMJOB,?2?
**
* Send a message to the originator.
// MSG (?5?,?6?),Job stream ?2? received and submitted to the JOBQ

```

It is not required that the received job stream be submitted to the job queue. The job stream could be evoked, or executed inline.

To evoke the job stream, the code from section AA above could be replaced with:

```
**
** AA
**
* Evoke the procedure member
// EVOKE ???,SUBMJOB
**
* Send a message to the originator
// MSG (?5?,?6?),Job stream ??? received and evoked
```

To execute the job stream inline, the code in section AA above could be replaced with:

```
**
** AA
**
* Execute the job stream
???,SUMBJOB
**
* Send a message to the originator with the return code
* from the previous job step
// MSG (?5?,?6?),Job stream ??? executed. Return code = ?CD?
**
* Remove the procedure member
REMOVE ???,PROC,SUBMJOB
```

A S/370 VM user, for example, can create a file using the XEDIT editor, the file will contain System/36 OCL. The VM user can then send the file to be executed at the System/36 by sending it to user ID JOB at your System/36.

```
SENDFILE MYJOB S36JOB A TO JOB AT S36SYS
```

Central Development - Local Edit, Remote Compile

A remote compiler could be maintained using Object Distribution Facility/36. Users on the systems without the compiler, could edit source code locally (on their system) and enjoy faster response times than if they were required to edit source code at the remote compiler system in a PASSTHRU session.

A dummy user ID and an arrival procedure can be used on the compiler system to allow the other system to submit compilations, as follows:

1. Create a dummy user ID on the compiler system. For example, RPGC.
2. Create an ODF/36 profile for user ID RPGC and specify:
 - Automatically submit jobs = 1 (yes)
 - Arrived objects procedure = COMPRPG
 - Library name = COMPRPG

Note: The procedure name and library name are examples only.

3. Create a library for the compiled programs.

Note: This procedure is included in the EXAMPLES diskette file. See Appendix B, "The EXAMPLES Diskette File."

COMPRPG:

```

* Called by ODF/36 when an object arrives
* Input parameters
* P1 = Object name 1
* P2 = Object name 2
* P3 = Object type
* P4 = Object sequence number
* P5 = From user ID
* P6 = From address
*
* If the object type is not DATA then do not process it.
// IFF ?3?='DATA ' RETURN
**
* Receive the object into library COMPRPG as a source member,
* the member name is object name part 2
RECVLIBR ?1?,?2?,?3?,?4?,COMPRPG,?2?,S
**
* Remove a load member of the same name if it exists.
// IF LOAD-'?2?,COMPRPG' REMOVE ?2?,LOAD,COMPRPG
**
* Set the printer to this systems dummy printer ID (P0).
* Set the forms number to the object sequence number, this can be
* used to help ensure a unique forms number.
* If the sequence number is 0001, then change the forms number to
* A001 to avoid picking the system default forms number.
// IF ?4?=0001 EVALUATE P4='A001'
PRINT P0,, ,?4?
**
* Send back a message indicating the compile is starting.
// MSG (?5?,?6?),Compile of ?2? starting.
**
* Compile the source member
RPGC ?2?,COMPRPG,NODSM,PRINT,NOXREF,0,NONEP,COMPRPG
**
* Send back a completion message for the compilation.
* Return code 1008 indicates the program did not compile.
// IF ?CD?=1008 MSG (?5?,?6?),Compile of ?2? failed.
// ELSE MSG (?5?,?6?),Compile of ?2? was successfull.
**
* Send the compilation listing back.
// LOCAL OFFSET-1,BLANK-1,AREA-SYSTEM
SENDPRT F?4?,CANCEL,?5?,?6?
**
* If a load member was created, then send it back.
// IF LOAD-'?2?,COMPRPG' SENDLIBR ?2?,LOAD,COMPRPG,,?5?,?6?

```

To compile an RPG program at the remote compiler system, send a library source member to user ID RPGC address COMPSYS in DATA format.

```
SENDLIBR RPG01,SOURCE,MYLIBR,DATA,RPGC,COMPSYS
```

The compilation listing and the compiled program (if the compilation was successful) is sent back to you.

Program Temporary Fix (PTF) Distribution

Program Temporary Fixes (PTFs) could be electronically distributed two ways:

1. Install PTFs on the central site system and send the PTF libraries to the remote site systems.
2. Install PTFs on the central site system and send only those library members with a PTF applied to the remote site systems.

Each method requires different considerations.

Distribute PTF Libraries

A PTF library on the System/36 is created by the PTF COPY procedure. A PTF library can be distributed using Object Distribution Facility/36 like any other library. That is, by using the SENDLIBR command and specifying ALL members of type LIBRARY.

For example, to send the system library (#LIBRARY) PTF library to user ODFADMIN SYS01.

```
SENDLIBR ALL,LIBRARY,PTFSS105,S36FMT,ODFADMIN,SYS01
```

At the remote system, the PTF APPLY procedure must be used to apply these PTFs to the system. This procedure requires a dedicated system and cannot be automated, for example, in an arrived objects procedure or a job stream.

Using this method ensures that PTF and PTF backup libraries exist at each remote system. This allows PTFs to be removed, if necessary, by using the PTF REMOVE procedure.

Distribute Members with a PTF Applied

After PTFs have been applied at the central site system, only those library members in the IBM libraries that have a PTF applied could be sent using the SENDLIBR procedure with PTF as the type. The PTFs could be automatically received and applied at the remote systems by using the RECVLIBR procedure in an arrived objects procedure.

For example, to send all members in the system library (#LIBRARY) that have a PTF applied.

```
SENDLIBR ALL,PTF,#LIBRARY,S36FMT,ODFADMIN,SYS01
```

Using this method allows PTFs to be automatically applied at each remote system. That is, a dedicated system is not required. However, applying PTFs in this way is similar to using the PTF DIRECT procedure in that no PTF or PTF backup libraries exist at each remote system, and, if required, PTFs could not be removed using PTF REMOVE.

Notes:

1. To copy IBM members into the system library (#LIBRARY) dynamically, replace-in-place cannot be performed. There must be sufficient contiguous free space at the end of the system library for the PTF members to be copied into. If a member is active at the time a new copy of that member is made in the system library, the new copy may not be used until the next IPL. This may cause a problem when two members in a PTF are required to be at the same level and

one of those members is active at the time the PTF members are copied to the system library.

2. Microcode PTFs cannot be sent using this method. To distribute microcode PTFs, the previous method of distributing PTF libraries must be used. In this example, only the library CSPTFLIB needs to be distributed in that way.

Printer Passthru

For a display station passthru user, there is a need to print output generated at the remote system on the local system. Different methods can be used for this function:

- A background job can monitor the spool file and route spooled print files to other systems.
- Passthru users can send spooled print files before they sign off the remote system.

A method is required at the remote system to prevent spooled output being printed before it is sent to the local system. If it is known that certain jobs will only be processed by passthru users, then those jobs could generate all spooled output at priority 0. Priority 0 spooled print files are placed in the system spool file with priority 1 and are held. These spooled print files could then be selected by forms number, assuming a common forms number was also used.

However, it may not always be possible to produce spooled output of priority 0. A dummy printer ID can be used to ensure that spooled output produced by passthru users is not printed at the remote system.

Example 1

Figure 4-2 shows an example printer passthru network.

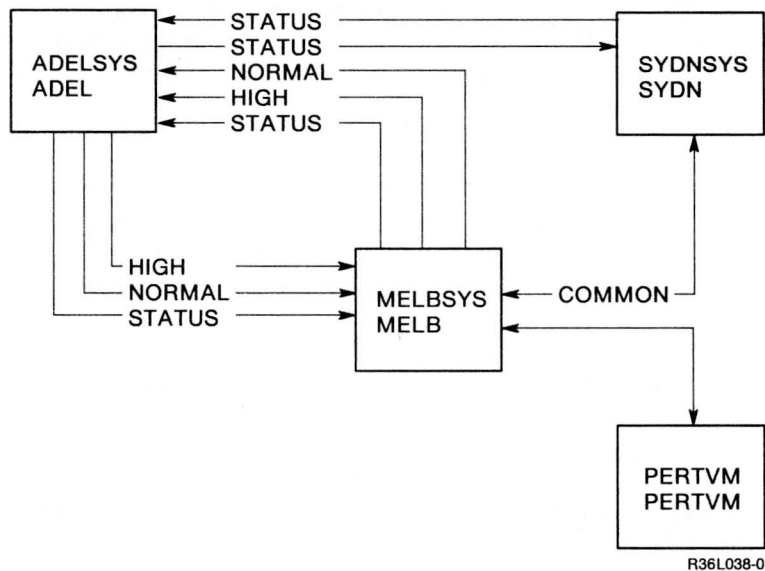

Figure 4-2. Example Printer Passthru Network

In this example, users in Adelaide (ADELSYS) and Sydney (SYDNSYS) passthru to the Melbourne system (MELBSYS). A dummy printer ID (P0) is configured at MELBSYS and passthru users direct their spooled output to this printer. Adelaide users always use a forms number of ADEL and Sydney users always use a forms number of SYDN. This can be automatically set up as each user signs on to the Melbourne system with a signon procedure.

A background procedure on the Melbourne system sends any spooled print files back to the appropriate system.

Note: This procedure is included in the EXAMPLES diskette file. See Appendix B, "The EXAMPLES Diskette File."

PRTPASS:

```
* Run at low priority to have least affect on interactive users.
// ATTR PRIORITY-LOW
**
* Check the spool file every 5 minutes.
// TAG LOOP
// WAIT INTERVAL-000500
**
* Send all Adelaide output to user AUTOPRT ADELSYS.
* Adelaide users set forms number ADEL.
SENDPRT FADEL,CANCEL,AUTOPRT,ADELSYS
**
* Send all Sydney output to user AUTOPRT SYDNSYS.
* Sydney users set forms number SYDN.
SENDPRT FSYDN,CANCEL,AUTOPRT,ADELSYS
**
// GOTO LOOP
```

The interval used, 5 minutes, can be set to any value you choose. A value too small will result in constant background processing which may affect interactive users response times.

User ID AUTOPRT at Adelaide and Sydney, could be a dummy user ID with an ODF/36 profile with *Automatically print spooled print files* set to 1 (yes). In this way, spooled output produced at the Melbourne system will automatically print at the passthru users local system without any intervention by the passthru user.

Note: The job return code could be tested after the execution of the SENDPRT procedure. If running evoked or from the job queue, the SENDPRT procedure will set the job return code for spool file related errors instead of issuing a system error message. See "SENDPRT Procedure" on page 3-70 for information on the return codes set by the SENDPRT procedure.

Example 2

Passthru users will send all their spooled output back to their local system before they sign off. As in example 1, passthru spooled output is sent to a dummy printer ID (P0). This can be set by the passthru users signon procedure.

Before each Adelaide passthru user signs off, they run the PRTADEL procedure.

Notes:

1. This could be built into the signoff option on the passthru user's menu, if you use your own menus.
2. This procedure is included in the EXAMPLES diskette file. See Appendix B, "The EXAMPLES Diskette File."

PRTADEL:

```
* Send all output generated by the requesting user ID back
* to the same user ID at ADELSYS.
SENDPRT ALL,CANCEL,?USER?,ADELSYS
```

In this scenario, there is no requirement to use a common forms number.

Each user can control how he wants spooled print files processed when they arrive at ADELSYS through his ODF profile.

Managing Communications in Batch

The STOPRSCS, STRTRSCS, and OFCCTRL procedures can be used in your own procedures to control communications. For example, the OFCCTRL procedure can be used in a procedure to wait until a certain time of day before sending distribution entries on the specified queue. This technique can be used to take advantage of cheaper tariffs.

See the "OFCCTRL Procedure" on page 3-48 for more information on the functions provided by this procedure.

Chapter 5. Cross-System Considerations

This chapter provides information on the differences in object naming conventions and object types between S/36, S/38, S/370, and the AS/400 system.

It is assumed that the reader is familiar with the system referred to in each section.

System/38

Note: System/38 can exchange objects with System/370 users by using a System/36 with Object Distribution Facility/36, or by using the AS/400 system with the RSCS/PROFS Bridge, as a gateway system. For VM considerations, see “VM/370” on page 5-3.

Object Naming Differences

System/38 CPF Object Naming Rules

Every name must begin with an alphabetic character (A-Z, \$, #, or @) and can be followed by no more than 9 alphanumeric characters (A-Z, 0-9, \$, #, @, or _). No name can exceed 10 characters. Blanks are not allowed in a name. When a library qualifier is used, a period (.) connects the object name to the library name.

Major Differences to Consider

- System/38 uses a period (.) for qualified object names. System/36 commonly uses a period (.) in file names to allow the files to be processed as a file group. An object with a period (.) in its name cannot be processed on System/38.
- System/38 object names can be up to 10 characters long. System/36 object names can be up to 8 characters long. When an object arrives for a System/36 user, the name is truncated to 8 characters by Object Distribution Facility/36. If an object is being forwarded by Object Distribution Facility/36, that is, if the System/36 is an intermediate point in the network, the object name is not truncated.
- System/36 allows special characters in file names. For example, (*, +, %). A period (.) is also commonly used in file names on System/36 to allow the files to be processed as a file group. Some IBM-supplied files and library members also contain special or reserved characters. These objects cannot be processed on a System/38.

General Object Differences

- The maximum record length supported on System/38 is 32 767 bytes. The maximum record length supported on System/36 is 4096 bytes. If an object arrives for a System/36 user and that object's record length is greater than 4096 bytes, the object cannot be processed by Object Distribution Facility/36. A message is sent to the recipient and originator of the object specifying that it could not be delivered. If an object is being forwarded by Object Distribution Facility/36, that is, if the System/36 is an intermediate point in the network, there is no restriction on the record length of the object.
- System/36 objects sent in S36FMT have no meaning to System/38. However, they can be received on System/38 for archiving. See “Archiving System/36 Objects on System/38.”
- A System/38 savefile has no meaning to System/36. However, a savefile can be received on System/36 for archiving. See “Archiving System/38 Objects on System/36.”

Archiving System/36 Objects on System/38

System/36 objects sent in S36FMT can be received into a physical file member on System/38, and can later be resent with no loss of System/36 attributes.

The System/36 objects are received as any other object by the RCVNETF command, and can later be resent as any other object using the SNDNETF command.

For the System/36 attributes to be preserved, the record length of the physical file *must* be 256 bytes.

Archiving System/38 Objects on System/36

A System/38 savefile can be received into a System/36 disk file as any other object, and can later be resent with no loss of System/38 attributes.

The System/38 savefile can be received using the LISTOBJ or RECVFILE procedures, and can later be resent as any other file using the SENDFILE procedure.

When sending a System/38 savefile (that was received into a System/36 disk file) with the SENDFILE procedure, the S36FMT or DATA parameters have no meaning and are ignored by Object Distribution Facility/36. The file will be sent in System/38 savefile format.

VM/370

Note: Other S/370 systems that support a connection to RSCS can exchange objects with System/36, System/38, or AS/400 users. However, VM is the only supported directly attached system to System/36 or the AS/400 system and is the only S/370 operating system discussed here.

The conversational monitor system (CMS) is the only VM system discussed here.

Object Naming Differences

VM/CMS File Naming Rules

The filename and filetype can be from one to eight characters. The valid characters are A-Z, a-z, 0-9, \$, #, @, +, hyphen (-), colon (:), and underscore (_). No name can exceed 8 characters. Blanks are not allowed in a name.

Major Differences to Consider

- System/36 IBM supplied objects commonly begin with the #, \$, or @ characters. The # and @ characters are line editing symbols in VM; when you use them to identify a file you must precede them with the logical escape symbol (^). See *Considerations for Line Mode Terminals* in the *VM/SP CMS User's Guide*.
- The filetypes EXEC and MODULE have special meaning to CMS. Usually, filenames that you choose for your files have no special significance to CMS. If, however, you choose a name that is the same as the name of a CMS command, and the file that you assign this name to has a filetype of MODULE or EXEC, you may have difficulty trying to execute the CMS command having the same name as the file.
- Lowercase letters within a name are valid for the CMS file system. However, some CMS commands do not support names that contain lowercase letters.

- The first character of names in the CMS file system is more flexible than System/36. A file from a S/370 system that does not meet System/36 naming conventions cannot be received using the S/370 name; however, it can be received by specifying a new name that conforms to System/36 conventions. You can do this during the receive process.

General Object Differences

- The maximum record length supported on System/36 is 4096 bytes. If an object arrives for a System/36 user and that object's record length is greater than 4096 bytes, the object cannot be processed by Object Distribution Facility/36. A message is sent to the recipient and originator of the object specifying that it could not be delivered. If an object is being forwarded by Object Distribution Facility/36, that is, the System/36 is an intermediate point in the network, there is no restriction on the record length of the object.
- The CMS file management routines support files with fixed- or variable-length records. System/36 supports only fixed-length records. When a variable-length file is received on System/36, the largest logical record of the variable-length record file is used as the fixed record length of the object into which you are receiving.
- System/36 objects sent in S36FMT have no meaning to VM/370. However, they can be received on VM/370 for archiving. See "Archiving System/36 Objects on VM/370."
- Spooled print files sent or received through the RSCS bridge have a maximum record length of 133 bytes (including control character). If a spooled print file has a record length greater than 133 bytes (including control character) the records will be truncated to 133 bytes as they cross the RSCS bridge.
- The following S/370 data formats are supported when an object is for an ODF/36 user. If the S/370 object is being forwarded by Object Distribution Facility/36, that is, if the System/36 is an intermediate point in the network, there is no restriction on the S/370 data formats supported.
 - PUNCH (HEADER)
 - Punch format with a header record (read card) present.
 - PUNCH (NOHEADER)
 - Punch format with no header record (read card).
 - DISK DUMP
 - Fixed- and variable-length record files are supported in this format.
 - NETDATA or DSMDDL
 - Fixed- and variable-length record files are supported in this format.
 - PRINT
 - S/370 print files.

If the format is not recognized, then PUNCH (NOHEADER) is assumed.
- Certain S/370 applications require that objects be in PUNCH, or 80 column card, format. For example, job submission to VM Batch or MVS/JES. The ODF/36 SENDFILE, SENDJOB, and SENDLIBR procedures allow objects to be sent in PUNCH format.

Archiving System/36 Objects on VM/370

System/36 objects sent in S36FMT can be received into a CMS file, and can later be resent with no loss of System/36 attributes. The READ command must be used to take an image copy of the object from your VM/CMS reader, and the PUNCH (NOHEADER command used to resend the object. This sends an image of the object as it was in your VM/CMS reader back into the network, and thus there is no loss of System/36 attributes.

The following are sample REXX execs which can be used to simplify the above process on your VM/CMS system.

ARCS3X

```
/* */
/* ARCS3X - Archive System/3X Objects */
/* */
/* The exec will read in a file from the user's reader and will */
/* preserve the image of the file in the reader. The file can */
/* later be sent with SNDS3X and no loss of attributes will occur. */
/* */
/* ARCS3X spool_id */
/* */
```

arg spid

```
if spid ='' then do
  say ' '
  say 'This exec will read in a file from your reader and will'
  say 'preserve the image of the file in the reader. The file can'
  say 'later be sent with SNDS3X and no loss of attributes will occur.'
  say ' '
  say 'Format: ARCS3X spool_id '
  exit(99)
end
```

```
'execio * CP ( STRING CP Q RDR' spid 'ALL *'
parse pull .
parse pull . . . . . fn ft .
'cp order rdr ' spid
'read ' fn ft
say 'Object ' fn ft ' has been archived. Resend with SNDS3X'
```

exit rc

```

SNDS3X

/* */
/* SNDS3X - Send System/3X Objects */
/* */
/* The exec will resend a System/3X object that was archived */
/* by the ARCS3X exec. The object will be sent with no loss of */
/* System/3X attributes. */
/* */
/* SNDS3X filename filetype filemode T0 userid AT node */
/* */

parse upper arg fn ft fm p1 touserid p2 tonode

if fn ='' | if ft ='' | if fm= '' | p1 ^= 'T0' | p2 ^= 'AT' then do
error:
say ' '
say 'This exec will resend a System/3X object that was archived'
say 'by the ARCS3X exec. The object will be sent with no loss of'
say 'System/3X attributes.'
say ' '
say 'Format: SNDS3X filename filetype filemode T0 userid AT node '
exit(99)
end

'ident (LIFO STACK'
parse pull . . . . rcsid .

'vmpush pun'
'cp tag de pu ' tonode touserid
'cp sp pu ' rcsid
'pu ' fn ft fm ' (noh'
'vmpop pun'

exit rc

```

AS/400 System

Object Naming Differences

AS/400 Object Naming Rules

Every name must begin with an alphabetic character (A-Z, \$, #, or @) and can be followed by no more than 9 alphanumeric characters (A-Z, 0-9, \$, #, @, period (.), or underline (_)). No name can exceed 10 characters. Blanks are not allowed in a name. When a library qualifier is used, a slash (/) connects the object name to the library name.

Major Differences to Consider

- The AS/400 system object names can be up to 10 characters long. System/36 object names can be up to 8 characters long. When an object arrives for a System/36 user, the name is truncated to 8 characters by Object Distribution Facility/36. If an object is being forwarded by Object Distribution Facility/36, that is, if the System/36 is an intermediate point in the network, the object name is not truncated.

General Object Differences

- The maximum record length supported on System/36 is 4096 bytes. If an object arrives for a System/36 user and that object's record length is greater than 4096 bytes, the object cannot be processed by Object Distribution Facility/36. A message is sent to the recipient and originator of the object specifying that it could not be delivered. If an object is being forwarded by Object Distribution Facility/36, that is, if the System/36 is an intermediate point in the network, there is no restriction on the record length of the object.
- An AS/400 savefile has no meaning to System/36. However, a savefile can be received on System/36 for archiving. See "Archiving AS/400 Objects on System/36."

Archiving System/36 Objects on the AS/400 System

System/36 objects sent in S36FMT can be received into a physical file member on the AS/400 system, and can later be resent with no loss of System/36 attributes.

The System/36 objects are received as any other object by the RCVNETF command, and can later be resent as any other object using the SNDNETF command.

For the System/36 attributes to be preserved, the record length of the physical file *must* be 256 bytes.

Archiving AS/400 Objects on System/36

An AS/400 savefile can be received into a System/36 disk file as any other object, and can later be resent with no loss of AS/400 attributes.

The AS/400 savefile can be received using the LISTOBJ or RECVFILE procedures, and can later be resent as any other file using the SENDFILE procedure.

When sending an AS/400 savefile (that was received into a System/36 disk file) with the SENDFILE procedure, the S36FMT or DATA parameters have no meaning and are ignored by Object Distribution Facility/36. The file will be sent in AS/400 savefile format.

Exchanging Objects with the AS/400 System/36 Environment

System/36 objects sent in S36FMT can be received into the AS/400 System/36 Environment with no loss of System/36 attributes. For example, a noncontiguous keyed indexed file sent from a System/36 in S36FMT can be received into the AS/400 System/36 Environment as a noncontiguous keyed indexed file.

System/36 files, library members, and folders can be sent to the AS/400 System/36 Environment.

The AS/400 System/36 Environment files and library members can be sent to a System/36 in S36FMT equivalent format.

Sending AS/400 System/36 Environment Objects

1. Use the SAVS36F or SAVS36LIBM command to save the AS/400 System/36 Environment objects into an AS/400 native physical file.
2. Use the SNDNETF command to send the physical file to the remote system.

Sending System/36 Environment file S36FILE1 to USER2 SYSTEM2

```
SAVS36F FROMFILE(S36FILE1) FROMLIB(QS36F) DEV(*PHYFILE)
PHYFILE(LIBRARY1/PHYFILE1)
```

Note: The name of the physical file to contain the System/36 environment file is not significant. The record length of the physical file must be 256 bytes. The physical file must already exist.

```
SNDNETF FILE(LIBRARY1/PHYFILE1) TOUSRID((USER2 SYSTEM2))
```

The file is now in a format equivalent to the ODF/36 SENDFILE procedure when sending in S36FMT. All System/36 attributes of the file are preserved when the file is received on a System/36.

Receiving objects into the AS/400 System/36 Environment

1. Use WRKNETF or RCVNETF to receive the network file into a physical file on the remote system.
2. Use RSTS36F or RSTS36LIBM or RSTS36FLR to restore the objects into the AS/400 System/36 Environment.

Receiving file FILE1 into the AS/400 System/36 environment

```
RCVNETF FROMFILE(LIBRARY1) FROMMBR(PHYFILE1) TOFILE(LIBRARY2/PHYFILE2)
```

Note: The name of the physical file to receive into is not significant. The record length of the physical file must be 256 bytes. The physical file must already exist.

```
RSTS36F TOFILE(S36FILE1) TOLIB(QS36F) DEV(*PHYFILE)
PHYFILE(LIBRARY2/PHYFILE2)
```

The network file could have been a file sent from the AS/400 System/36 Environment, as in the previous example, or a file sent from a System/36 in S36FMT by the ODF/36 SENDFILE procedure.

All System/36 file attributes are preserved.

See *Programming: Control Language Programmer's Guide* for more information on the SAVS36F, SAVS36LIBM, RSTS36F, RSTS36LIBM, and RSTS36FLR commands. See *Communications: Distribution Services Network Administrator's Guide* for more information on the WRKNETF, RCVNETF, and SNDNETF commands. See *Programming: Concepts and Programmer's Guide for the System/36 Environment* for more information about the AS/400 System/36 Environment, and the AS/400 equivalent commands for Object Distribution Facility/36 functions.

Chapter 6. Problem Determination

Distribution Log File Manager

The ODF/36 distribution log file manager provides a means to track the status of an object during the distribution. ODF/36 programs call the distribution log file manager to log the important events in the process of distributing an object such as sending an object, routing an object, receiving an object, or deleting an object.

The distribution log file manager is a background task that must be active for ODF/36 to run. It is started along with the other ODF/36 background task by running the ODFSTART procedure.

The distribution log entries are written to the distribution log file which is a direct access disk file with a record length of 256 bytes. This file created during installation. For more information on creating the distribution log file, see Chapter 2, "Setting Up ODF/36."

When the file fills up, the distribution log file manager will wrap the file and write records over the top of existing entries start at the front of file. For a description of the layout of records in the distribution log file, see Figure 6-1.

Starting Position	Length	Description
01	10	Distribution log sequence number (Ascending 10-byte hexadecimal number of each log entry)
11	01	Log entry type: L = Normal log entry E = Error log entry (see error code)
12	06	Date entry was made (system date in character format)
18	06	Time entry was made
24	06	System program making the entry
30	08	JOB name of system program making the entry
38	08	Address of sender
46	08	User ID of sender
54	04	Sequence number generated on sending system in character format
58	08	Time, in SNADS format, the distribution was sent (the SNADS format is an 8-byte binary value, bytes 1 and 2 are the year, byte 3 is the month, byte 4 is the day, byte 5 is the hour, byte 6 is minute, byte 7 is the second, byte 8 is the hundredth second)
66	08	Address of recipient

Figure 6-1 (Part 1 of 3). Distribution Log File Record Layout

Starting Position	Length	Description
74	08	user ID of recipient
82	06	Sequence number, in character format, on the destination system
88	08	Time, in SNADS format, the distribution was received (the SNADS format is an 8-byte binary value, bytes 1 and 2 are the year, byte 3 is the month, byte 4 is the day, byte 5 is the hour, byte 6 is minute, byte 7 is the second, byte 8 is the hundredth second)
96	16	ODF/36 folder member name. This entry is an 8-byte binary value converted to character format for display.
112	02	Folder member type. This entry is a 1-byte binary value converted to character for display. 7A = Data member type 7C = ODF/36 profile member type 81 = Distribution list member type
114	10	First part of object name
124	10	Second part of object name
134	08	RSCS link name
142	02	Function code 01 = New ODF/36 folder member created by SENDxxxx procedure 02 = ODF/36 folder member deleted 03 = Route to PS/36 (SNADS) 04 = Receive distribution from SNADS 05 = Route to RSCS queue manager 06 = Receive distribution from RSCS 07 = Object received by local user 08 = Object deleted from user list of arrived objects 09 = Object submitted to run 0A = RSCS lock byte decremented 0B = #NTDF lock byte decremented 0C = Local lock byte decremented 0D = Object arrived for local user 0E = Spooled print file printed 0F = Object deleted from RSCS queue 10 = RSCS distribution list member created 11 = Local lock byte set 12 = RSCS lock byte set

Figure 6-1 (Part 2 of 3). Distribution Log File Record Layout

Starting Position	Length	Description
144	02	13 = #NTDF lock byte set 14 = Ignore local acknowledgement request 15 = Distribution sent on RSCS link Distribution error codes AG = Member older than purge value, member deleted CN = Lock byte is zero or data member is incomplete, data member is deleted ND = Distribution list member with no corresponding data member, distribution member deleted BD = Data member has bad data, member deleted DD = Error occurred creating distribution list member, member deleted SN = Error occurred using PS/36 (SNADS) DS = Error occurred trying to distribute object JN = Error occurred trying to evoke jobstream NP = No user profile exists for this ODF/36 profile, profile deleted XX = Unexpected error occurred in ODF/36 ZR = Lock byte decrement request, but lock byte already at zero BX = Error occurred trying to transform object EL = Empty RSCS distribution list FP = Flush partially received object
146	7	Number of records in object. This is set only when an object is sent, or has arrived for a user.
153	4	Record length of object. This is set only when an object is sent, or has arrived for a user.
157	100	Exception data

Figure 6-1 (Part 3 of 3). Distribution Log File Record Layout

Programs that Create Log File Entries

The distribution log file can be used for error tracking, tracking the distribution of an object or auditing usage of ODF/36. Below is a list of the ODF/36 programs that log entries and the function codes these programs log:

\$NTIPL ODF/36 IPL

Called by the ODFIPL procedure.

- 02 = ODF/36 folder member deleted

\$NTLCK ODF/36 Lock Byte Manager

This is an ODF/36 background task.

- 02 = ODF/36 folder member deleted
- 0A = RSCS lock byte decremented
- 0B = #NTDF lock byte decremented
- 0C = Local lock byte decremented

- \$NTLIS** ODF/36 List Arrived Objects
Called by the LISTOBJ procedure.
- 08 = Object deleted from user list of arrived objects
- \$NTLNK** ODF/36 RSCS Link Manager
Called by the STRTRSCS procedure; runs as an ODF/36 background task.
- 02 = ODF/36 folder member deleted
 - 06 = Receive distribution from RSCS
 - 15 = Distribution sent on RSCS link
- \$NTQLS** ODF/36 List RSCS Objects Queued to be Sent
Called by the LISTRSCS procedure.
- 02 = ODF/36 folder member deleted
 - 0F = Object deleted from RSCS queue
- #NDTP** ODF/36 SNADS to Local Transaction Program
Called by the #da002 procedure; evoked by Personal Services/36 (SNADS).
- 04 = Receive distribution from SNADS
- #NTDF** ODF/36 Distribute Function Transient
Called by the SENDxxxx procedures, program #NDTP, and program #NTRR.
- 02 = ODF/36 folder member deleted
 - 03 = Route to PS/36 (SNADS)
 - 05 = Route to RSCS queue manager
 - 09 = Object submitted to run
 - 0D = Object arrived for local user
 - 0E = Spooled print file printed
 - 10 = RSCS distribution list member created
 - 11 = Local lock byte set
 - 12 = RSCS lock byte set
 - 13 = #NTDF lock byte set
 - 14 = Ignore local acknowledgement request
- #NTRF** ODF/36 Receive File
Called by the RECVMFILE procedure, and program \$NTLIS.
- 07 = Object received by local user
- #NTRL** ODF/36 Receive Library Members
Called by the RECVLIBR procedure, and program \$NTLIS.
- 07 = Object received by local user

- #NTRP** ODF/36 Receive Spooled Print File
Called by the RECVPRT procedure, and program \$NTLIS.
- 0E = Spooled print file printed
- #NTRT** ODF/36 Receive Folder
Called by the RECVFLDR procedure, and program \$NTLIS.
- 07 = Object received by local user
- #NTRR** ODF/36 RSCS Distribution Router
Called by program \$NTLNK.
- 02 = ODF/36 folder member deleted
- #NTSF** ODF/36 Send File
Called by the SENDFILE procedure.
- 01 = New ODF/36 folder member created by SENDxxxx
- #NTSL** ODF/36 Send Library Members
Called by the SENDLIBR procedure.
- 01 = New ODF/36 folder member created by SENDxxxx
- #NTSP** ODF/36 Send Spooled Print file
Called by the SENDPRT procedure.
- 01 = New ODF/36 folder member created by SENDxxxx
- #NTST** ODF/36 Send Folder
Called by the SENDFLDR procedure.
- 01 = New ODF/36 folder member created by SENDxxxx
- #NTTP** ODF/36 SNADS to RSCS Transaction Program
Called by the #DFCSRVR procedure; evoked by Personal Services/36 (SNADS).
- 04 = Receive distribution from SNADS
 - 05 = Route to RSCS queue manager

Considerations for Processing the Distribution Log File

The distribution log file is always active while ODF/36 is running. The distribution log file is allocated DISP-SHRMR (allocated for update, share with read). If you plan to write programs to extract information from the distribution log file you *must* always copy the distribution log file and use this copy for your processing. This will ensure you are working with a static copy of the file, and also ensures that you will not prevent other ODF/36 functions from completing.

Note: The ODFCANCL procedure cannot complete if you are using the distribution log file.

Use the following example OCL to copy the distribution log file. Do not use the SSP COPYDATA, LISTDATA, or LISTFILE procedures against the distribution log file. These procedures all specify DISP-SHRRR and will wait indefinitely for allocation of the distribution log file.

Note: The procedure is included in the EXAMPLES diskette file. See Appendix B, "The EXAMPLES Diskette File."

COPYODFL

```
// LOAD $COPY
// FILE NAME-COPYIN,LABEL-#ODFLOGF,UNIT-F1,DISP-SHRRM
// FILE NAME-COPYO,LABEL-?1R?,UNIT-F1
// RUN
// COPYFILE OUTPUT-SAME
// END
* COPYODFL Procedure
* Parameter 1. Name of file to create.
```

Entries in the distribution log file are not in any particular order. The date and time fields can be used to logically sort your copy of the distribution log file if required.

Chapter 7. Improving System Performance

This chapter describes some design aspects of Object Distribution Facility/36 and offers tips on how to keep your system running efficiently.

This chapter is intended for the advanced user.

Sizing the ODF Folder

General Information on Folders

A folder is a named area on disk that contains members such as documents, profiles, mail, data definitions, or Object Distribution Facility/36 objects and user profiles. These different members are known as **member types**.

A folder is composed of a **directory**, which contains information about the members in the folder, and a number of **folder extents**, which contain the members themselves.

The folder directory contains an entry with the name and description of each member in the folder. A folder can have multiple member types.

Folder members are stored in disk areas called folder extents. As members are added to the folder, new extents are created if the current extent(s) become filled. The first part of each folder extent is used to keep track of the folder space within that extent.

When the system attempts to place a member into a folder extent that cannot contain the member, the system automatically creates an additional extent into which the member can be placed. A Folder can have up to 99 extents.

When the system attempts to place a member into a folder and the folder directory for that member type cannot contain the member, the system automatically enlarges the folder directory by finding an available larger area on disk and copying the folder directory to that disk area. The disk area that contained the original folder directory is then freed. A folder can have only one folder directory.

The folder directory is known as the data descriptor area (DDA), and the folder extent(s) is known as the data text area (DTA).

Some folder member types have no DTA. These require an entry in the folder directory only and do not require space in the folder extent(s).

Your system's performance can be affected by the size and number of extents of the ODF folder.

ODF Folder Design

The ODF folder is used to store all objects that have arrived for Object Distribution Facility/36 users, all objects that are queued to be sent on an RSCS link, and Object Distribution Facility/36 user profile information.

Notes:

1. Objects that are queued to be sent on a Personal Services/36 (SNADS) queue are stored in the SNADS storage folder (\$O USSFL).
2. Objects queued to be sent to RSCS can be objects routed through this system.

The ODF folder has three member types:

- Data members** A data member is any object that has arrived for an Object Distribution Facility/36 user, or any object queued to be sent on an RSCS link. There is only ever one copy of an object in the ODF folder. The list of local recipients (users on this system that the object has arrived for) is stored in the directory entry for a data member. A data member requires both an entry in the folder directory (DDA) and space in the folder extents (DTA).
- Distribution members** A distribution member contains the list of recipients for an object that is queued to be sent on an RSCS link. One distribution member is created per RSCS link. A distribution member requires only an entry in the folder directory (DDA).
- User members** A user member contains the information in each user's Object Distribution Facility/36 profile. A user member requires only an entry in the folder directory (DDA).

Example

A user sends an object to five recipients. After the recipients are resolved by searching the directory, the object will be distributed to three users on this system, one recipient via RSCS link RSCS1, and one recipient via RSCS link RSCS2.

Note: A remote recipient can be the name of a distribution list on the target system.

One data member (data member 1) is created in the ODF folder. The DDA (folder directory entry) for this member contains the list of the three local recipients: LOCAL1, LOCAL2, LOCAL3. The object itself will be contained in the DTA (space in the folder extents).

Two distribution members will be created: Distribution member 1 contains the remote recipient REMOTE1 ADDRESS1 and the name of data member 1 in its folder directory entry. Distribution member 2 will contain the remote recipient REMOTE2 ADDRESS2 and the name of data member 1 in its folder directory entry.

Note: Distribution members have no DTA.

These members would appear in the folder as shown in Figure 7-1:

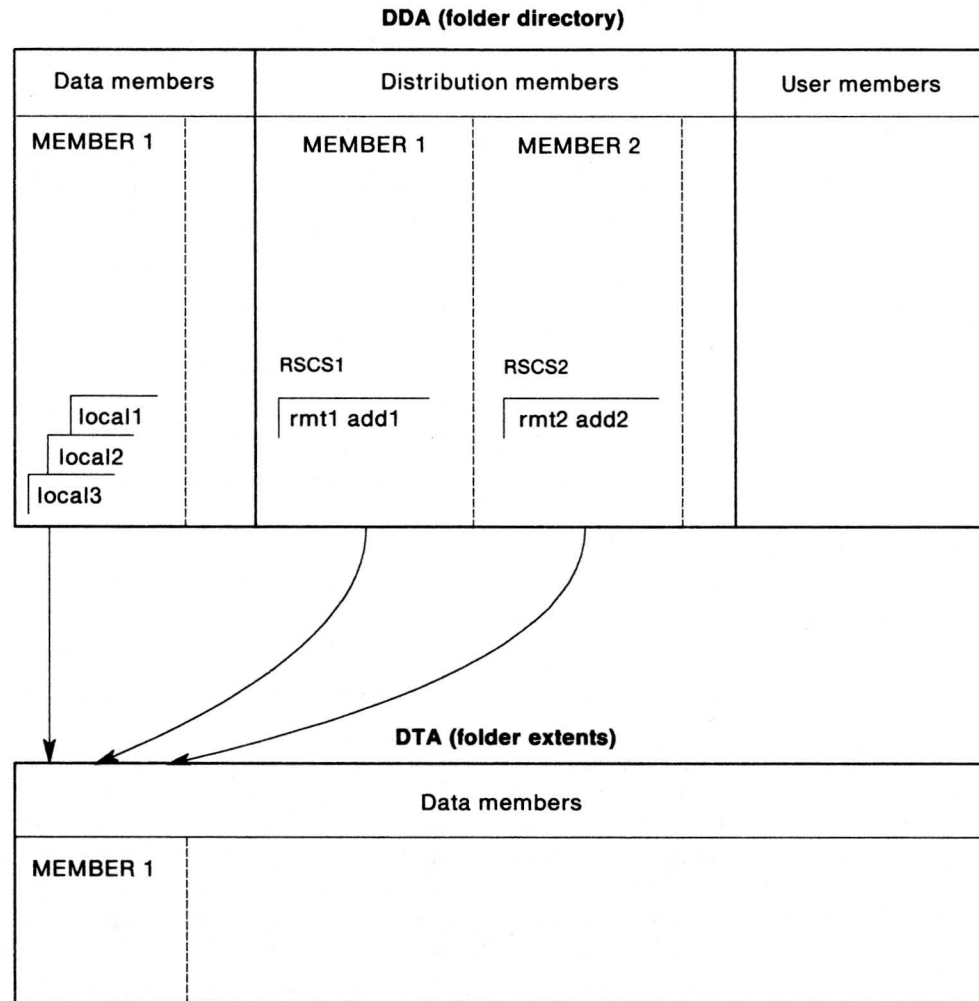

R36L048-0

Figure 7-1. How Members in the ODF/36 Folder are Related

Note: If the object is also destined for remote recipients via Personal Services/36 (SNADS) queue(s), then during the send object processing the object would be concurrently written to the ODF/36 folder and the SNADS storage folder (\$OUSSFL).

Each of the five owners of the object (user LOCAL1, user LOCAL2, user LOCAL3, RSCS link RSCS1, and RSCS link RSCS2) see a logical copy of the object. The object will not be deleted from the folder until the last owner of the object requests that his logical copy be deleted.

Creating the ODF Folder

The ODFINSTL procedure is used to create the ODF folder, see “Initializing Object Distribution Facility/36” on page 2-5 and “ODFINSTL Procedure” on page 3-40. The following prompt is displayed for creation of the ODF folder:

```

CREATE ODF FOLDER
ODF folder #ODFFLDR

The ODF folder is used to store all objects sent from or arrived for users,
and for all objects sent through this system.
Objects remain in this folder until ODF/36 users receive or delete them,
or until they have remained in the ODF folder the number of days
specified by the object purge interval.

Type choices, press Enter

ITEM                CHOICE  POSSIBLE CHOICES
Number of objects . . . . . 00050   Average (1-32767)
Size of objects in blocks . . . 00010   Average (1-15000)
Number of ODF/36 users. . . . . 0020    Maximum (1-3998)
Will RSCS be used?. . . . . 2        1=Yes 2=No
Cmd3=Go back                Cmd7=End

```

The following rules are used when determining the size of the ODF folder:

- The size of the primary DTA (the first folder extent) is calculated by multiplying the *Number of objects* by the *Size of objects in blocks*. The secondary extent(s) size is always 50 % of the primary DTA size.

The default values shown above would result in the primary DTA extent being 500 blocks, and each additional extent will be 250 blocks.

- The size of the DDA (folder directory) is calculated as follows:
 - The size of the DDA for data members is calculated to contain twice the *Number of objects*.

Note: This is an average value, thus the maximum is calculated to contain twice the value entered.

The default value shown above would result in 100 entries being created for data members in the DDA.

- The size of the DDA for user members is set to contain the *Number of ODF/36 users*.

The default value shown above would result in 20 entries being created for user members in the DDA.

- The size of the DDA for distribution members is determined by the response to *Will RSCS be used?*. If the answer is yes, then the size is set to contain the *Number of objects*. If the answer is no, then size is set to 1.

Note: It is assumed that on average, half of the objects will be for local users (users on this system) and half will be for RSCS. Half the maximum number of objects in the folder is the *Number of objects*. See the earlier point on the size of the DDA for data members.

The default value shown above would result in 50 entries being created for distribution members in the DDA.

The extend value for the DDA is set to be 50 % of the initial DDA size.

Use the information presented to carefully size the ODF folder.

Try to avoid DDA (folder directory) extensions, as these are expensive operations. All users of the folder will wait while the DDA extension process is running.

Folders are designed to have multiple DTAs (folder extents), however as the number of DTAs increases, performance decreases. It is suggested that the number of DTAs be kept to six or less.

It is better to overestimate the size of the ODF folder. Underestimating the size of the DDA results in expensive DDA extensions. Underestimating the size of the DTA results in DTA extents being created more often, and each extent being smaller than optimum.

The ODF folder can be reorganized by the ALOCFLDR procedure. The *System Reference manual*, contains more information about the ALOCFLDR procedure.

How Extents Affect the Task Work Area

If the size of the task work area is too small, this can significantly impact performance. Run the System Measurement Facility (SMF) during a period of heavy usage, and use the detail report to see if the task work area has extents. More information about SMF can be found in the manual *System Measurement Facility Guide*.

If the report shows one extent, make the task work area larger by using the CNFIGSSP procedure. A suggested starting size is 2500 blocks. Then run SMF again to be sure there are no extents. If there are still extents, repeat until there are none. The *System Reference manual*, contains more information about the CNFIGSSP procedure.

Sending Objects in S36FMT or DATA

Choosing S36FMT or DATA as the format to be used on an ODF/36 SEND command can affect the amount of processing required by the system to complete your send request. This processing can be in how the object(s) to be sent are read from disk, and how often the distribution process is required to be performed.

Sending Files in S36FMT or DATA

S36FMT

When you request that a file be sent in S36FMT, Object Distribution Facility/36 knows that this file will only have meaning to another System/36, or to the AS/400 System/36 Environment, and that it is not required to process the file logically by record. That is, to read each record in the file in the same fashion that a user RPGII program would read a file. Therefore, Object Distribution Facility/36 uses the disk hardware read function to read the disk sectors that comprise the file. This is a very fast operation and requires virtually no main storage processor overhead.

The file is read from disk 64 sectors, or 16K at a time. Thus only one disk op is required for every 16K of data in the selected file.

DATA

When you request that a file be sent in DATA, Object Distribution Facility/36 knows that this file will could be for any system type and that the data in in the file must be processed logically. That is, record by record.

Object Distribution Facility/36 uses disk data management to read the file logically by record. A blocking factor of 40 is used which means that disk data management will perform one disk op for every 40 records in the file. However, a call to disk data management must be made for every record in the file, and this does require main storage processor overhead.

Determining Which to Use

Where you have the choice of sending in either S36FMT or DATA, always use S36FMT. The difference in time to perform a send request in DATA versus S36FMT increases dramatically with the number of records in the file.

Note: When receiving a file, the disk hardware write function is always used to write 64 sectors, or 16K, of data at a time. This is regardless of whether the file was sent in S36FMT or DATA.

Sending Library Members in S36FMT or DATA

S36FMT

When you request that library members be sent in S36FMT, all the library members selected are packaged and sent as a single distribution. The contents of each library member are read directly from disk and are not expanded or decompressed.

DATA

When you request that library members be sent in DATA, only source or procedure members can be sent, and each member selected is sent as a separate distribution. The source and procedure members are read from disk and are expanded and decompressed to be sent as record images.

Determining Which to Use

If you are sending to another System/36 or the AS/400 System/36 Environment then always use S36FMT. There is less processing involved in getting the data out of the library, and only one distribution needs to be processed. If sending in DATA, then each member to be sent must be sent as record images and must be distributed separately. This extra distribution processing will place more load on your system.

Appendix A. ODF/36 Utility Programs

This appendix shows the ODF/36 utility programs you can use instead of the ODF/36 procedures. The utility programs are in alphabetic order by utility, with a description of the functions that can be performed using that utility, and the OCL and utility control statements (if applicable) that can be used to perform that function.

Example

This example shows how you can create a procedure to send different object types with only one invocation of the \$NTSNO utility program.

```
* SENDPAY procedure
// LOAD $NTSNO
// RUN
// SENDF FILE-ALL,GROUP-PAY,USERID-?1?,ADDRESS-?2?
// SENDR FOLDER-PAYFLDR,USERID-?1?,ADDRESS-?2?
// SENDL MEMBER-ALL,LIBR-PAYLIBR,TYPE-LIBRARY,USER-?1?,ADDRESS-?2?
// END
*
* Sample procedure to distribute a payroll application
* All files in group PAY are sent.
* Folder PAYFLDR is sent.
* All members in library PAYLIBR are sent.
*
* Parameter 1: User ID to which the application will be sent
* Parameter 2: Address to which the application will be sent
```

\$NTSNO Utility

The \$NTSNO utility program allows you to:

- Send a file or file group (SENDFILE procedure)
- Send a folder (SENDFLDR procedure)
- Send a job stream (SENDJOB procedure)
- Send library member(s) (SENDLIBR procedure)
- Send spooled print file(s) (SENDPRT procedure)

Sending Disk Files (SENDFILE Procedure)

See "SENDFILE Procedure" on page 3-59 for more information.

Sending a Single Disk File

```
// LOAD $NTSNO
// RUN

// SENDF FILE-file name,USERID-user ID,ADDRESS-address [ ,DATE-creation date ]

[ ,FORMAT- { S36FMT
              DATA
              PUNCH } ] [ ,PRIORITY-priority
                        50 ] [ ,RSCSDST-rscs distribution code ]

[ ,RSCSCLS-rscs class
  A ] [ ,ACKNLDG- { NOACK
                    ACK } ]

// END
```

R36L049-1

Sending a File Group

```
// LOAD $NTSNO
// RUN

// SENDF FILE-ALL,GROUP-group name,USERID-user ID,ADDRESS-address

[ ,FORMAT- { S36FMT
              DATA
              PUNCH } ] [ ,PRIORITY-priority
                        50 ] [ ,RSCSDST-rscs distribution code ]

[ ,RSCSCLS-rscs class
  A ] [ ,ACKNLDG- { NOACK
                    ACK } ]

// END
```

R36L050-1

\$NTSNO (SENDFLDR)

Sending a Folder (SENDFLDR Procedure)

See "SENDFLDR Procedure" on page 3-63 for more information.

```
// LOAD $NTSNO
// RUN

// SENDR FOLDER-folder name,USERID-user ID,ADDRESS-address

    [ ,PRIORITY-priority ] [ ,RSCSDST-rscs distribution code ]
        50

    [ ,RSCSCLS-rscs class ] [ ,ACKNLDG- { NOACK
        A                               ACK } ]

// END
```

R36L051-1

Sending a Job Stream (SENDJOB Procedure)

See "SENDJOB Procedure" on page 3-65 for more information.

```

// LOAD $NTSNO
// RUN

// SENDJ MEMBER-member name,TYPE- $\left\{ \begin{array}{l} \text{SOURCE} \\ \text{(S)} \\ \text{PROC} \\ \text{(P)} \end{array} \right\}$ ,LIBR-library name,USERID-user ID,

ADDRESS-address  $\left[ \text{,FORMAT-} \left\{ \begin{array}{l} \text{DATA} \\ \text{PUNCH} \end{array} \right\} \right]$ ,  $\left[ \text{PRIORITY-priority} \right]$ 
 $\left[ \text{,RSCSDST-rscs distribution code} \right]$ ,  $\left[ \text{RSCSCLS-rscs class} \right]$   $\left[ \text{,ACKNLDG-} \left\{ \begin{array}{l} \text{NOACK} \\ \text{ACK} \end{array} \right\} \right]$ 

// END

```

R36L052-2

\$NTSNO (SENDLIBR)

Sending Library Member(s) (SENDLIBR Procedure)

See "SENDLIBR Procedure" on page 3-67 for more information.

```
// LOAD $NTSNO
// RUN

// SENDL MEMBER- { member name
                  { member name.ALL } , LIBR-library name, USERID-user ID,

ADDRESS-address , TYPE- { SOURCE
                        { (S)
                          PROC
                          (P)
                          SUBR
                          (R)
                          LOAD
                          (O)
                          PTF
                          (F)
                          LIBRARY
                          (L)
                        } , [ , FORMAT- { S36FMT
                                        { DATA
                                        { PUNCH
                                        } ] ] [ , PRIORITY-priority
                                        { 50
                                        } ] ]

[ RSCSDST-rscs distribution code ] [ , RSCSCLS-rscs class
                                   { A
                                   } ] [ , ACKNLDG- { NOACK
                                                    { ACK
                                                    } ] ]

// END
```

R36L053-1

\$NTSNO (SENDPRT)

Appendix B. The EXAMPLES Diskette File

This appendix shows the examples in this manual that are included in the EXAMPLES diskette file.

How to Load the Examples

The EXAMPLES diskette file is a librarian file. To load the examples insert volume 1 of the ODF/36 diskettes in slot 1 and use the TOLIBR procedure.

```
TOLIBR EXAMPLES,I1,,YOURLIB,S1,,ALL,LIBRARY
```

YOURLIB is the library you wish the examples to be copied into. This library must already exist on the system.

Examples Cross-Reference

The following chart shows the examples included in the EXAMPLES diskette file and where they are referenced in this manual.

Example Name	Function Performed	Page
ARRIV001	Receive all arrived objects into files	4-9
ARRIV002	Generic receive arrived objects	4-9
ARRIV003	Submit job streams from S/370 users	4-11
COMPRPG	Compile remote RPG programs	4-13
COPYODFL	Copy the distribution log file	6-7
JOB00001	Retrieve system information	4-4
PRTADEL	Send all spooled output at signoff	4-18
PRTPASS	Background printer passthru	4-18

Figure B-1. ODF/36 Examples Quick Reference

Appendix C. Object Distribution Facility/36 Messages

This appendix lists and describes messages that appear when an error condition in ODF/36 occurs. This appendix is intended to help the user understand the reasons that these messages appear and how to respond to them.

Messages can appear:

- At the bottom of a display.
- At a display station. These messages are recorded in the system history file and if options 0, 1, 2 or 3 are present, the messages offer additional information. Press the Enter key to see the additional information.
- At the system console. Users do not normally see these messages. These messages are recorded in the system history file. To respond to messages, see the *Operating Your Computer manual*.
- In the history file only. Users do not normally see these messages.

ODF-8055 Job [library name] [member name] for [user ID] [address] not submitted

Explanation

The job stream that was sent to the user on an AS/400 system or a S/38 arrived. The job stream was rejected because either the network characteristic for JOBACN is *REJECT or the network job entry for the remote user specifies *REJECT or no network job entry was found for the remote user.

Correct the condition that caused the job stream to be rejected. Then send the job stream again.

ODF-8070 Object [object name 1] [object name 2] arrived for [user ID] [address]

Explanation

The object sent to the user named in the message arrived and was placed in that user's list of arrived objects.

ODF-8073 Job [library name] [member name] submitted for [user ID] [address]

Explanation

The job stream sent to a remote user arrived at that remote system and was successfully submitted.

ODF-8075 Unexpected error received [error number] [replacement text with error]

Explanation

An unexpected message arrived from an AS/400 system or S/38. The message number and part of the replacement text is included in the message. See the AS/400 system administrator for an explanation of the AS/400 message.

ODF-8076 Job [library name] [member name] from [user ID] [address] not submitted

Explanation

The job stream sent to a remote user could not be submitted because of an error condition detected at the remote system.

Additional information

Refer to the history file on the remote system for the error condition that caused this message to occur.

ODF-8078 Object [object name 1] [object name 2] arrived from [user ID] [address]

Explanation

An object has arrived for you and is in your list of arrived objects.
Use LISTOBJ to work with the arrived object.

ODF-8079 Job [library name 1] [member name 2] submitted from [user ID] [address]

Explanation

A job stream sent from the remote user named in the message was submitted under your user profile.

ODF-8080 object [object name 1] [object name 2] not sent to [number] users

Explanation

The object named in the message was not delivered to the the specified number of users because an error condition was detected on the receiving system. Refer to the history file on the receiving system for the error that caused this message to be generated.

ODF-8081 [object name 1] [object name 2] Error in distribution [message number]

Explanation

An error condition was detected on the receiving system when trying to deliver the object named in the message.
The specific error message is listed in the message.

Correct the condition that caused the error and try to send the object again.

ODF-8082 [object name 1] [object name 2] printed for [user ID] [address]

Explanation

The spooled print file named in the message sent to the user named in the message arrived and was automatically printed.

ODF-8083 Job [object name 1] [object name 2] printed from [user ID] [address]

Explanation

A spooled print file sent from the the user named in the message to you was automatically printed.

ODF-8084 [spooled print file] not printed from [user ID] [address]

Explanation

The spooled print file named in the message sent from the user named in the message did not print because an error was detected in the distribution. The error that caused this message is listed in the history file.

Correct the error condition and have the spooled print file sent again.

ODF-8086 SNADS error[message number] in distribution, not sent to [number] users

Explanation

A PS/36 (SNADS) error was detected trying to deliver an object to one or more users. The error message number detected by PS/36 (SNADS) is listed. After correcting the condition that caused the message, try sending the object again.

Additional information

The full range of codes that could be received from PS/36 (SNADS) follows:

'0005' : More destinations left
'0006' : Permanent server error
'0007' : Invalid server name
'0008' : Invalid server parameter
'0009' : No directory entry
'000E' : Resource not available
'000F' : System error
'0010' : Temporary server error
'0011' : I/O system error
'0012' : Null password
'0013' : No destinations given
'0014' : Queue in use
'0015' : Acknowledge expected
'0016' : Receive expected
'0020' : Queue empty
'0021' : Protocol error
'0022' : Not authorized to object
'0023' : Not authorized to queue
'0024' : Unsupported service level
'0025' : Parameter check
'0026' : Invalid queue ID
'0027' : Use count error
'0028' : End of data
'0029' : Invalid document password
'0030' : Invalid document name
'0031' : First 4 characters of document TMIO not 'TMIO'
'0034' : Buffer length not equal to 4K on a read
'0035' : Document not open
'0036' : Associate record not found on a read

ODF-8087 [user ID] [address] Invalid recipient

Explanation

The user named in the message cannot receive objects using ODF/36 because he or she is not correctly defined to the system.

Additional information

Contact the system administrator or your security officer to add the user ID to the directory file or to change it if it is invalid.

Additional information

See "Creating Directory Files" on page 2-13 for a description of how set up the PS/36 (SNADS) environment.

ODF-8088 #DFCSRVR can not be started from the job queue/display station

Explanation

#DFCSRVR is an internal procedure used by ODF/36 and cannot be run from a display station, the JOBQ or EVOKED. It can only be started from PS/36 (SNADS) when an object is routed to an RSCS link.

ODF-9652 [object name 1] [object name 2] has been received by [user ID]

Explanation

The object in the message was received successfully by the user ID named in the message.

ODF-9653 Enter the RSCS system name

Explanation

The RSCS system name was missing on the procedure statement.

Enter the name of the RSCS system.

User Response

option 2: The job step is ended. Any data created up to this point is saved, and the job can continue with the next step.

option 3: The job is canceled. Data created by previous steps in this job are saved, but data created in this step are lost.

ODF-9654 Sequence number must be 0000 - 9999...

Explanation

The sequence number is invalid. The number must be 4 digits (0000 to 9999) with no alphabetic characters.

Enter option 2 or 3. If this is part of a job step, give the programmer the message ID. Otherwise, enter the procedure again with the correct sequence number.

User Response

option 2: The job step is ended. Any data created up to this point is saved, and the job can continue with the next step.

option 3: The job is canceled. Data created by previous steps in this job are saved, but data created in this step are lost.

ODF-9655 Both object names must be specified...

Explanation

To receive an object, both the object name 1 and object name 2 must be specified.

Enter option 2 or 3. If this is part of a job step, give the programmer the message ID. Otherwise, enter the procedure again specifying both object name 1 and object name 2.

User Response

option 2: The job step is ended. Any data created up to this point is saved, and the job can continue with the next step.

option 3: The job is canceled. Data created by previous steps in this job are saved, but data created in this step are lost.

ODF-9656 Object type must be specified

Explanation

To receive an object, the object type must be specified.

Enter option 2 or 3. If this is part of a job step, give the programmer the message ID. Otherwise, enter the procedure again specifying both object name 1 and object name 2.

User Response

option 2: The job step is ended. Any data created up to this point is saved, and the job can continue with the next step.

option 3: The job is canceled. Data created by previous steps in this job are saved, but data created in this step are lost.

ODF-9657 Container must be FILE, LIBRARY, FOLDER or PRINT...

Explanation

To receive an object, the container type must be specified. A valid container types is one of the following:

- FILE
- LIBRARY
- FOLDER
- PRINT

Enter option 2 or 3. If this is part of a job step, give the programmer the message ID. Otherwise, enter the procedure again specifying the correct container type for the object you are trying to receive.

User Response

option 2: The job step is ended. Any data created up to this point is saved, and the job can continue with the next step.

option 3: The job is canceled. Data created by previous steps in this job are saved, but data created in this step are lost.

ODF-9658 REPLACE option must be REPLACE or blank

Explanation

To receive an object, the REPLACE option must be either REPLACE or left blank.

Enter option 2 or 3. If this is part of a job step, give the programmer the message ID. Otherwise, enter the procedure again specifying either replace or blank.

User Response

option 2: The job step is ended. Any data created up to this point is saved, and the job can continue with the next step.

option 3: The job is canceled. Data created by previous steps in this job are saved, but data created in this step are lost.

ODF-9659 No object found matching search criteria...

Explanation

RECVFILE, RECVFLDR, RECVLIBR, RECVPRT was run to receive an object. However, there are no objects that match all of the search criteria that has been specified. Either the object has already been processed or the search criteria was specified incorrectly.

Enter option 2 or 3. If this is part of a job step, give the programmer the message ID. Otherwise, enter the procedure again specifying the correct parameter for the object being received.

User Response

option 2: The job step is ended. Any data created up to this point is saved, and the job can continue with the next step.

option 3: The job is canceled. Data created by previous steps in this job are saved, but data created in this step are lost.

ODF-9660 Cannot receive [object name 1] [object name 2] into [object type]...

Explanation

The specified object cannot be stored into the container type entered.

Enter option 2 or 3. If this is part of a job step, give the programmer the message ID. Otherwise, enter the procedure again specifying the correct container type for the object being received.

User Response

option 2: The job step is ended. Any data created up to this point is saved, and the job can continue with the next step.

option 3: The job is canceled. Data created by previous steps in this job are saved, but data created in this step are lost.

ODF-9661 Cannot receive into specified member type...

Explanation

When receiving into a library member, only SOURCE or PROCEDURE can be specified.

Enter option 2 or 3. If this is part of a job step, give the programmer the message ID. Otherwise, enter the procedure again specifying either SOURCE or PROCEDURE for the library member type.

User Response

- option 2:** The job step is ended. Any data created up to this point is saved, and the job can continue with the next step.
- option 3:** The job is canceled. Data created by previous steps in this job are saved, but data created in this step are lost.

ODF-9662 **Invalid purge interval found in #ODFFLDR...**

Explanation

The purge interval specified in the ODF/36 system default profile is invalid. The ODF/36 system defaults must be reset.

Enter option 2 or 3. Run ODFDFLT to reset the purge interval and then run ODFIPL.

Additional Information

For a description of how of how to set or change the system defaults for ODF/36, see "Object Distribution Facility/36 Defaults" on page 2-10.

User Response

- option 2:** The job step is ended. Any data created up to this point is saved, and the job can continue with the next step.
- option 3:** The job is canceled. Data created by previous steps in this job are saved, but data created in this step are lost.

ODF-9663 **[label name] Invalid label entered...**

Explanation

The label entered for a file, library or folder is invalid. Valid labels must start with A-Z, #, \$, or

@ and cannot contain embedded blanks or commas.

If you are running LISTOBJ, reenter a valid file, library or folder label and try the receive operation again.

If you are running RECVFILE, RECVLIBR, or RECVFLDR, enter option 2 or 3.

If this is part of a job step, give the programmer the message ID. Otherwise, enter the procedure again specifying a valid file, library or folder label.

User Response

- option 2:** The job step is ended. Any data created up to this point is saved, and the job can continue with the next step.
- option 3:** The job is canceled. Data created by previous steps in this job are saved, but data created in this step are lost.

ODF-9664 **RSCS link [link name] is not active...**

Explanation

The specified RSCS link is not active.

You ran STOPRSCS to stop the RSCS link specified in the message. However, that RSCS link is not active.

Enter option 0, 2 or 3. If this is part of a job step, give the programmer the message ID. Otherwise, if the RSCS link name was not entered correctly, enter the procedure again specifying an active RSCS link name.

User Response

- option 0:** The job step continues onto the next RSCS link name, if present. The inactive RSCS link name is ignored.
- option 2:** The job step is ended. Any data created up to this point is saved, and the job can continue with the next step.
- option 3:** The job is canceled. Data created by previous steps in this job are saved, but data created in this step are lost.

ODF-9665 **RSCS link [link name] already active**

Explanation

The specified RSCS link is already active.

Enter option 3. If this is part of a job step, give the programmer the message ID. Otherwise, if the RSCS link name was not entered correctly, enter the procedure again specifying the correct RSCS link name.

User Response

option 3: The job is canceled. Data created by previous steps in this job are saved, but data created in this step are lost.

ODF-9666 RSCS signon rejected.

[sent RSCS node]

[sent S/36 node]

[received RSCS node]

[received S/36 node]

Explanation

The signon was rejected by this system because the the default system named defined to PS/36 (SNADS) is not the same as defined to RSCS, or the RSCS system name specified on the STRTRSCS command does not match the RSCS system name defined to RSCS. The systems names exchanged when STRTRSCS was run are included in the message text. Give the message ID and system names to the programmer.

Additional Information

For a description of how to set the default system name, see "Personal Services/36 (SNADS) Defaults" on page 2-24. For a description of how to set the RSCS set of how to set system names on RSCS, refer to the *VM/RSCS PRPQ 5799-DAE*

**ODF-9667 System error received from SNADS
[SNADS error message number]**

Explanation

An error condition was detected by PS/36 (SNADS). The specific error message is returned in the message text.

Do one of the following:

- Try the operation again.
- Give the system administrator the the message ID (ODF-9667) along with the PS/36 (SNADS) error number returned in the message.

Additional information

The full range of codes that could be received from PS/36 (SNADS) follows:

'0005' : More destinations left
'0006' : Permanent server error
'0007' : Invalid server name
'0008' : Invalid server parameter
'0009' : No directory entry
'000E' : Resource not available
'000F' : System error
'0010' : Temporary server error
'0011' : I/O system error
'0012' : Null password
'0013' : No destinations given
'0014' : Queue in use
'0015' : Acknowledge expected
'0016' : Receive expected
'0020' : Queue empty
'0021' : Protocol error
'0022' : Not authorized to object
'0023' : Not authorized to queue
'0024' : Unsupported service level
'0025' : Parameter check
'0026' : Invalid queue ID
'0027' : Use count error
'0028' : End of data
'0029' : Invalid document password
'0030' : Invalid document name
'0031' : First 4 characters of document
TMIO not 'TMIO'
'0034' : Buffer length not equal to
4K on a read
'0035' : Document not open
'0036' : Associate record not found
on a read

ODF-9668 Disk Directory Error

Explanation

A disk error occurred trying to access the directory file.

Do one of the following:

- Try the operation again.
- Give the programmer the message ID (ODF-9668)

ODF-9670 Resolved list exceeds 150 elements

Explanation

An object was sent to a distribution list, but the resolved list exceeds the maximum allowed size. The object was not sent.

Contact the system administrator to change the distribution list.

ODF-9671 Disk error on list file

Explanation

A disk error occurred trying to access the S/36 list file.

Do one of the following:

- Try the operation again.
- Give the programmer the message ID (ODF-9668)

ODF-9672 Resolve not done, circular list

Explanation

You are trying to send an object to a distribution list, but the list cannot be resolved because it has distribution lists that include each other.

Additional Information

Contact the system administrator to change the distribution list.

ODF-9673 Resolve not done, imbedded lists exceed 20

Explanation

An object was sent to a distribution list, but the list contains more than 20 imbedded lists. The object was not sent.

Additional Information

Contact the system administrator to change the distribution list.

ODF-9674 System error resolving list [System error message number]

Explanation

You are trying to send an object to a distribution list, but an unexpected error occurred while the system was trying to resolve the list. The error message number is contained in the message.

Do one of the following:

- Try the operation again.
- Give your programmer the message ID (ODF-9674) along with the returned error message ID.

ODF-9675 Could not find PS/36 module

Explanation

The system tried to send an object to a remote PS/36 (SNADS) user, but a system error occurred trying to find a required PS/36 module.

Do one of the following:

- Try the operation again.
- Give your programmer the message ID (ODF-9675).

Additional Information

If this error continues to occur, fill out a Problem Summary Form found in the *System Problem Determination* manual and call for software service.

ODF-9676 No user profile found for [user ID]

Explanation

An ODF/36 operation was attempted with the user ID specified in the message. However, password security is active and he or she does not have a user profile in the user ID file.

If present, select option 2 or 3.

Do one of the following:

- If this is part of a job step, give the programmer the message ID (ODF-9676).
- Contact the security officer to add a user profile to the user ID file.
- Try the procedure again specifying a valid user ID.

User Response

option 2: The job step is ended. Any data created up to this point is saved, and the job can continue with the next step.

option 3: The job is canceled. Data created by previous steps in this job are saved, but data created in this step are lost.

ODF-9677 [object name 1] [object name 2] Record length exceeds 4096

Explanation

The object named in the message cannot be processed on this system because the record length exceeds 4096 characters. If the object is also being routed to another system, the processing will continue for that system.

ODF-9678 [object name 1] [object name 2] Object cannot be processed

Explanation

The data transformation for at least one of data formats: PS/36 (SNADS), RSCS or local delivery could not be performed. If the remaining data transformations were successful, processing will continue.

ODF-9679 STOP parameter is invalid...

Explanation

The stop parameter specified for the ODFCANCL procedure is invalid. The stop parameter must be STOPLOG, STOPLOCK, STOPQMGR or blank.

Enter option 2 or 3. If this is part of a job step, give the programmer the message ID. Otherwise, enter the procedure again specifying a valid stop parameter.

User Response

option 2: The job step is ended. Any data created up to this point is saved, and the job can continue with the next step.

option 3: The job is canceled. Data created by previous steps in this job are saved, but data created in this step are lost.

ODF-9680 No arrived objects for [user ID]

Explanation

LISTOBJ was run to list a user's arrived objects to disk. However, there are no arrived objects for that user ID.

Enter option 2 or 3.

User Response

option 2: The job step is ended. Any data created up to this point is saved, and the job can continue with the next step.

option 3: The job is canceled. Data created by previous steps in this job are saved, but data created in this step are lost.

ODF-9681 Not authorized to list objects for [user ID]

Explanation

The user is not authorized to list objects for the the user ID listed in the message.

Either,

- The user is a security officer, but must be a master security officer to list objects for other security officers or master security officers.
- The user is not authorized to list objects for other users.

If the LISTOBJ procedure was run to list objects to disk, enter option 2 or 3.

User Response

option 2: The job step is ended. Any data created up to this point is saved, and the job can continue with the next step.

option 3: The job is canceled. Data created by previous steps in this job are saved, but data created in this step are lost.

ODF-9684 Not authorized to run ODF/36 procedure...

Explanation

The user is not authorized to run the ODF/36 procedure. The procedure requires the user to have at least security officer classification to run.

Enter option 2 or 3.

User Response

option 2: The job step is ended. Any data created up to this point is saved, and the job can continue with the next step.

option 3: The job is canceled. Data created by previous steps in this job are saved, but data created in this step are lost.

ODF-9701 Complete list shown, cannot roll

Explanation

The entire list is shown on the current display, there are no more list entries to display.

ODF-9703 No arrived objects

Explanation

There are no objects in the list of arrived object for the user ID selected.

ODF-9704 The top of the list of arrived objects was reached.

Explanation

Roll up was pressed to display the previous page of arrived objects, but the top of the list is already displayed.

ODF-9705 The bottom of the list of arrived objects was reached.

Explanation

Roll down was pressed to display the next page of arrived objects, but the bottom of the list is already displayed.

There are no more objects in the list of arrived objects.

ODF-9706 Invalid option; select one of the options shown

Explanation

An invalid option was chosen for this display.

To continue, enter one of the options listed for this display.

ODF-9707 Cannot refresh the list with options pending

Explanation

Cmd5 was pressed to refresh the list of arrived objects for the user ID selected. However, this function cannot be performed if there are any options pending.

Do one of the following before trying this operation again:

- Press the Enter key to process the pended options.
- Press Cmd8 to clear all the pended options.

ODF-9708 Cannot subset the list with options pending

Explanation

Cmd1 was pressed to subset the list of arrived objects for the user ID selected. However, this function cannot be processed if there are any options pending.

Do one of the following before trying this operation again:

- Press the Enter key to process the pended options.
- Press Cmd8 to clear all the pended options.

ODF-9709 Invalid option for type [object type]

Explanation

An option was chosen that is not valid for the object type of that arrived object.

Select the option that is appropriate for that object. For additional information about what options are valid for each object type, press the Help key or see Figure 3-19 on page 3-16.

ODF-9710 Object no longer in list of arrived objects

Explanation

An option was chosen to receive, print or delete an object from the list of arrived objects. However, another user has already processed that arrived object. It is no longer in the list of arrived objects.

ODF-9711 The top of the data reached

Explanation

The roll up key was pressed to show the previous display or Cmd1 was pressed to show the first display of data. However, you are already on the first display.

ODF-9712 The bottom of data was reached

Explanation

The roll down key was pressed to show the next display or Cmd2 was pressed to show the last

display of data. However, the last display is already being displayed.

ODF-9713 Cannot Select new user with options pending

Explanation

Cmd2 was pressed to select a new user to work with. However, this function cannot be performed if there are any options pending.

Do one of the following before trying the operation again:

- Press the Enter key to process the pended options.
- Press Cmd8 to clear all the pended options.

ODF-9714 No objects queued to be sent

Explanation

LISTRSCS was RUN LISTRSCS to display the objects queued to be sent on an RSCS node. However, at this time there are no queued objects to display.

Do one of the following:

- Press Cmd3 or Cmd7 to end the procedure.
- Press Cmd5 to refresh the display.

ODF-9716 [number] members copied to [member name], [number] not copied

Explanation

A LIBR type member was copied to a library.

The number of members that were successfully and unsuccessfully copied are specified in the message. If the number of members not copied is greater than zero, an error message has been written to the history file for each member that has an error.

ODF-9717 [member name] Invalid member name entered

Explanation

The member name specified is invalid. Valid member names must start with A-Z, #, \$, or @ and cannot contain embedded blanks or commas. Also, the names DIR or ALL are not allowed.

To continue, enter a valid member name.

ODF-9718 [member name] in .[library name] is empty

Explanation

An attempt was made to receive a type DATA object into a library member. However, the specified object is empty.

If LISTOBJ was run RUN, select option 4 to delete the arrived object from the list of arrived objects.

If RECVLIBR was run, enter option 2 or 3. Run LISTOBJ and select option 4 to delete the arrived object from the list of arrived objects.

User Response

option 2: The job step is ended. Any data created up to this point is saved, and the job can continue with the next step.

option 3: The job is canceled. Data created by previous steps in this job are saved, but data created in this step are lost.

ODF-9719 [library name] in [member name] not received...

Explanation

Option 3 was selected to receive an arrived object of type data into a library. However, there is not enough room in the specified library to receive the member.

If RECVLIBR was run, enter option 2 or 3.

Do one of the following:

- Make space available in the library by either deleting unnecessary library members or by increasing the size of the library. Condense the library by running the CONDENSE procedure

to remove gaps in the library and accumulate all the unused space at the end of the library.

- Increase the size of the library by running the ALOCLIBR procedure.
- Select a different library to receive the object.

ODF-9720 [library name] library in use

Explanation

An attempt was made to receive an object into library. However, the library is in use at this time.

If RECVLIBR was run, enter option 2 or 3. Try the operation at a later time.

ODF-9721 Resource not available

Explanation

There is not enough task work area to perform the function requested.

To continue, try the operation again because the needed storage might be available now. If the error continues to occur, you might have to wait for other display stations that are using system resources to finish with their jobs, or you might have to increase the size of task work area. For more information on increasing the size of the task work area, refer to the manual, *Changing Your System Configuration*, .

ODF-9722 Remote file [file name] cannot be sent in S36FMT...

Explanation

An attempt was made to send a remote file in S36FMT. However, remote file can only be processed in data format.

If present, select option 2 or 3.

To continue, send the file in data format.

User Response

option 2: The job step is ended. Any data created up to this point is saved, and the job can continue with the next step.

option 3: The job is canceled. Data created by previous steps in this job are saved, but data created in this step are lost.

ODF-9723 [library name] Invalid directory found

Explanation

The arrived object of type LIBR being received contains an invalid directory entry for a library member. Processing cannot continue for this arrived object. Any members previously processed have been copied into the specified library.

If present, select option 2 or 3.

Additional Information

If this error continues to occur, fill out a Problem Summary Form found in the *System Problem Determination* manual and call for software service.

User Response

option 2: The job step is ended. Any data created up to this point is saved, and the job can continue with the next step.

option 3: The job is canceled. Data created by previous steps in this job are saved, but data created in this step are lost.

ODF-9724 File [file name] is empty, cannot be sent

Explanation

SENDFILE was run to send a file to another user. However, the file cannot be sent because it is empty.

If present, select option 2 or 3.

User Response

option 2: The job step is ended. Any data created up to this point is saved, and the job can continue with the next step.

option 3: The job is canceled. Data created by previous steps in this job are saved, but data created in this step are lost.

ODF-9725 RSCS Queue Manager not active...

Explanation

The RSCS link task cannot run if the RSCS queue manger is not active. This may be because ODFCANCL was run to cancel all ODF/36 background tasks and the the RSCS link task has not ended yet.

If present, select option 2 or 3.

To start the ODF/36 background tasks, run ODFSTART.

User Response

option 2: The job step is ended. Any data created up to this point is saved, and the job can continue with the next step.

option 3: The job is canceled. Data created by previous steps in this job are saved, but data created in this step are lost.

ODF-9726 [number] files in group [file group] sent, [number] not sent

Explanation

A file group was sent using SENDFILE. The group name is identified in the message as well as the number of files successfully sent and the number of files not sent because of an error. If the number not sent is greater than zero, the history file will contain an entry for each file in error.

ODF-9728 ODF/36 distribution log manager not active...

Explanation

No ODF/36 procedures can be started because the ODF/36 distribution log manager is not active. This may be because ODFCANCL was run to cancel all ODF/36 background tasks or because ODFSTART was not run after IPL. ODFIPL should be included in the startup procedure #STRUP1. ODFSTART should be included into the startup procedure #STRUP2.

If present, select option 2 or 3.

To start the ODF/36 background tasks, run ODFSTART.

User Response

- option 2:** The job step is ended. Any data created up to this point is saved, and the job can continue with the next step.
- option 3:** The job is canceled. Data created by previous steps in this job are saved, but data created in this step are lost.

ODF-9729 [number] members in library sent,
[number] members not sent

Explanation

One or more library members were sent using SENDLIBR. The library name is identified in the message as well as the number of members successfully sent and the number of members not sent because of an error. If the number not sent is greater than zero, the history file will contain an entry for each member in error.

ODF-9730 [object name 1] [object name 2] record
length invalid for library member...

Explanation

An attempt was made to receive the object named in the message into a library member. However, the object being received has an invalid record length for a source or procedure library member. The record length for a source or procedure member must at least 40 characters and cannot be longer than 120 characters. The object was not received.

The object can only be received into a file.

ODF-9732 [file name] cannot replace multiple
index files...

Explanation

An attempt was made to receive an arrived object into a file specifying REPLACE. However, the existing file cannot be replaced because it has associated alternative index files.

If LISTOBJ was run, enter a different file label and try the operation again.

If RECVFILE was run, enter option 2 or 3. Try the operation again, specifying a different file label.

User Response

- option 2:** The job step is ended. Any data created up to this point is saved, and the job can continue with the next step.
- option 3:** The job is canceled. Data created by previous steps in this job are saved, but data created in this step are lost.

ODF-9733 Cannot replace, [file name] is not a
file

Explanation

An attempt was made to receive an arrived object into a file specifying REPLACE. However, the file label entered references an existing library or folder on disk.

If LISTOBJ was run, enter a different file label and try the operation again.

If RECVFILE was run, enter option 2 or 3. Try the operation again, specifying a different file label.

User Response

- option 2:** The job step is ended. Any data created up to this point is saved, and the job can continue with the next step.
- option 3:** The job is canceled. Data created by previous steps in this job are saved, but data created in this step are lost.

ODF-9734 ODF/36 distribution log file
#ODFLOGF has wrapped

Explanation

The distribution log file, #ODFLOGF, has filled and is wrapping on itself writing over the existing records starting with first record in the file.

This is an informational message. If the distribution log file wraps too frequently, you may consider deleting the file and re-creating it with a larger size using the ODFINSTL procedure.

ODF-9735 Dictionary/Definition not found for [file name]...

Explanation

The file being received was externally linked to a dictionary and file definition when it was sent. When sending externally described files, the data dictionary and definition should also be sent and received before receiving the files that uses it.

ODF/36 tried to link to the same dictionary and definition. For the file being received, however, the dictionary or file definition was not found on this system.

Do one of the following:

- Enter option 0 to receive the file even though the dictionary or file definition was not found. The file will not be externally linked after the receive.
- Enter option 1 to not receive the file, but to continue processing.
- Enter option 2 or 3. The file will not be received and will remain in the list of arrived objects.

User Response

- option 0:** The receive will continue. However, the file specified in the message will not be externally linked after the receive.
- option 1:** The file will not be received and the processing continues.
- option 2:** The job step is ended. Any data created up to this point is saved, and the job can continue with the next step.
- option 3:** The job is canceled. Data created by previous steps in this job are saved, but data created in this step are lost.

ODF-9736 Dictionary for file [file name] is in use...

Explanation

The file being received was externally linked to a dictionary and file definition when it was sent. When sending externally described files, the data dictionary and definition should also be sent and received before receiving the files that uses it.

For the file being received, however, the dictionary or file definition is in use and cannot be accessed.

Do one of the following:

- Enter option 0 to receive the file even though the dictionary or file definition is in use. The file will not be externally linked after the receive.
- Enter option 1 to continue processing without receiving the file.
- Enter option 2 or 3. The file will not be received and will remain in the list of arrived objects.

User Response

- option 0:** The receive will continue. However, the file specified in the message will not be externally linked after the receive.
- option 1:** The file will not be received and the processing continues.
- option 2:** The job step is ended. Any data created up to this point is saved, and the job can continue with the next step.
- option 3:** The job is canceled. Data created by previous steps in this job are saved, but data created in this step are lost.

ODF-9737 ODF/36 Lock byte manager not active...

Explanation

No ODF/36 procedures can be started because the ODF/36 lock byte manager is not active.

If present, select option 2 or 3.

To start the ODF/36 background task, run ODFSTART. This may be because ODFCANCL was run to cancel all ODF/36 background tasks or because ODFSTART was not run after IPL. ODFIPL should be included in the startup procedure #STRUP1. ODFSTART should be included into the startup procedure #STRUP2.

User Response

- option 2:** The job step is ended. Any data created up to this point is saved, and the job can continue with the next step.

option 3: The job is canceled. Data created by previous steps in this job are saved, but data created in this step are lost.

ODF-9738 File level for [file name] does not match definition...

Explanation

The file being received was externally linked to a dictionary and file definition when it was sent. When sending externally described files, the data dictionary and definition should also be sent and received before receiving the files that uses it.

For the file being received however, the change level of the current definition differs from the change level of the definition when the file was sent. This means that either the definition or dictionary has been changed in some way since the file was sent.

Do one of the following:

- Enter option 0 to receive the file and link it to the dictionary even though the dictionary or file definition has changed since the file was sent. The file will be externally linked after the receive.
- Enter option 1 to receive the file, and not link to the dictionary. The file will not be externally linked after the receive.
- Enter option 2 or 3. The file will not be receive and will remain in the list of arrived objects.

User Response

option 0: The receive will continue. The file specified in the message will be externally linked to the same dictionary as it was when it was sent. The file will be externally linked after the receive.

option 1: The receive will continue. However, the file specified in the message will not be externally linked after the receive.

option 2: The job step is ended. Any data created up to this point is saved, and the job can continue with the next step.

option 3: The job is canceled. Data created by previous steps in this job are saved, but data created in this step are lost.

ODF-9739 Record length for [file name] does not match definition...

Explanation

The file being received was externally linked to a dictionary and file definition when it was sent. When sending externally described files, the data dictionary and definition should also be sent and received before receiving the files that uses it.

ODF/36 tried to link to the same dictionary and definition. For the file being received, however, the file's record length is different from the record length specified by the file definition in the dictionary.

Do one of the following:

- Enter option 0 to receive the file without linking it to the dictionary. The file will not be externally linked after the receive.
- Enter option 1 to continue processing without receiving the file.
- Enter option 2 or 3. The file will not be received and will remain in the list of arrived objects.

User Response

option 0: The receive will continue. However, the file specified in the message will not be externally linked after the receive.

option 1: The file will not be received and the processing continues.

option 2: The job step is ended. Any data created up to this point is saved, and the job can continue with the next step.

option 3: The job is canceled. Data created by previous steps in this job are saved, but data created in this step are lost.

ODF-9740 Missing or invalid parameter

Explanation

The information entered is not correct for the fields that are shown in reverse image. Processing cannot continue until the fields in error are corrected.

To continue, enter the information correctly. For more information about correcting the fields, press

the HELP key or refer to the appropriate section in this manual for the procedure being run.

ODF-9741 Missing parameters, cannot run from JOBQ or EVOKED

Explanation

An attempt was made to run an ODF/36 procedure from the JOBQ or EVOKED. However, one or more of the required parameters was left blank. All the required parameters must be specified to run this procedure from the JOBQ or EVOKED.

Enter option 2 or 3. If this is part of a job step, give the programmer the message ID. Otherwise, enter the procedure again and specify all the required parameters. For more information on which parameters are required, see the appropriate section in this manual for the procedure being run.

ODF-9742 Send request has been processed

Explanation

The send request has been processed and the distribution process has been initiated to deliver the object. This is an informational message only.

ODF-9743 Group - ALL not allowed

Explanation

SENDFILE was run to send a file group. However, the group name ALL is not allowed.

If present, select option 2 or 3. If this is part of a job step, give the programmer the message ID. Otherwise, enter the procedure again with the a valid group name.

User Response

option 2: The job step is ended. Any data created up to this point is saved, and the job can continue with the next step.

option 3: The job is canceled. Data created by previous steps in this job are saved, but data created in this step are lost.

ODF-9744 Send request ignored

Explanation

Cmd3 was pressed to cancel the send request. No objects were sent.

This is an informational message only.

ODF-9745 One recipient required for a send request

Explanation

A user ID/address was not entered on the *ADD USER LIST* display.

To continue, enter a valid user ID/address.

ODF-9746 Sending user ID [user ID] not found or invalid

Explanation

An Attempt was made to send an object using ODF/36. This cannot be done because the sending user does not have a user ID in the directory file or the directory entry the user ID is invalid.

If present, select option 2 or 3.

Additional information

Contact the system administrator or the security officer to add the user ID to the directory file or to change it if it is invalid.

User Response

option 2: The job step is ended. Any data created up to this point is saved, and the job can continue with the next step.

option 3: The job is canceled. Data created by previous steps in this job are saved, but data created in this step are lost.

ODF-9747 Error trying to access directory

Explanation

An attempt was made to send an object using ODF/36. However, an unexpected error occurred trying to access the directory file.

Do one of the following:

- If present, select option 2 or 3. Try the operation again.
- Give the programmer the message ID (ODF-9747).

Additional information

If this error continues to occur, fill out a Problem Summary Form found in the *System Problem Determination* manual and call for software service.

User Response

- option 2:** The job step is ended. Any data created up to this point is saved, and the job can continue with the next step.
- option 3:** The job is canceled. Data created by previous steps in this job are saved, but data created in this step are lost.

ODF-9748 Default system address not found

Explanation

An attempt was made to send an object using ODF/36. This cannot be done because the system default address has not been defined. The system default address must be specified to send objects using ODF/36.

If present, select option 2 or 3.

Additional information

Contact the system administrator or your security officer to define the system default address using the OFCINSTL procedure. For more information about the system default address, see "Personal Services/36 (SNADS) Defaults" on page 2-24.

User Response

- option 2:** The job step is ended. Any data created up to this point is saved, and the job can continue with the next step.
- option 3:** The job is canceled. Data created by previous steps in this job are saved, but data created in this step are lost.

ODF-9753 Invalid recipient

Explanation

An attempt was made to send an object using ODF/36. This cannot be done because one of the recipients specified to send the object to is not in the directory file or is incorrectly defined.

If present, select option 2 or 3.

Additional information

Contact the system administrator or your security officer to add the user ID to the directory file or to change it if it is invalid.

User Response

- option 2:** The job step is ended. Any data created up to this point is saved, and the job can continue with the next step.
- option 3:** The job is canceled. Data created by previous steps in this job are saved, but data created in this step are lost.

ODF-9754 Type choices, press Enter to update

Explanation

Type the information into the fields displayed. Press the Enter key to update the ODF/36 user profile.

ODF-9755 [user ID] profile created

Explanation

The information entered was used to create the ODF/36 user profile.

ODF-9756 [user ID] profile does not exist, press Enter to create

Explanation

An ODF/36 user profile does not exist for this user ID. Enter the information for this user ID and

press the Enter key to create the ODF/36 user profile.

ODF-9757 [user ID] profile has been deleted

Explanation

The ODF/36 user profile for the user ID displayed has been deleted.

ODF-9758 [user ID] profile updated

Explanation

The ODF/36 user profile for the user ID shown has been updated with the information shown on the display.

ODF-9759 Type user ID, press Enter

Explanation

Enter a user ID for the ODF/36 user profile to display. If it exists and you are authorized to see it, it will be displayed.

ODF-9760 ODFIPL has not been run, ODF/36 cannot start...

Explanation

The ODFIPL procedure must be run to set up the ODF/36 environment. Also, the ODFSTART procedure must be run to initiate the the ODF/36 background tasks before any of the ODF/36 procedures can be run.

Enter option 2 or 3. Run the ODFIPL procedure and the ODFSTART procedure before trying the operation again.

Additional Information

For a description of how to run the ODFIPL procedure, see "ODFIPL Procedure" on page 3-41. For a description of how to run the ODFSTART procedure, see "ODFSTART Procedure" on page 3-46.

User Response

option 2: The job step is ended. Any data created up to this point is saved, and the job can continue with the next step.

option 3: The job is canceled. Data created by previous steps in this job are saved, but data created in this step are lost.

ODF-9761 Maximum RSCS links active, cannot start [RSCS link name]

Explanation

The maximum number of RSCS links, eight, are already active. The RSCS link named in the message cannot be started. An active RSCS link must be stopped before starting another RSCS link.

Enter option 2 or 3 to cancel the procedure.

Do one of the following:

- If this is part of a job step, give the message ID(ODF-(9761) to your programmer.
- Stop an active RSCS link using the STOPRSCS command before retrying the operation.

User Response

option 2: The job step is ended. Any data created up to this point is saved, and the job can continue with the next step.

option 3: The job is canceled. Data created by previous steps in this job are saved, but data created in this step are lost.

ODF-9762 Unexpected error on link [link name] MAJMIN [major minor return code]

Explanation

An unexpected communications error has occurred. The RSCS link has terminated. The ICF BSCCL major minor code is given in the message.

Do one of the following:

- Try the operation again.
- Give the programmer this message ID(ODF-9762) and the ICF BSCCL return code.

Additional Information

If this error continues to occur, fill out a Problem Summary Form found in the *System Problem Determination* manual and call for software service.

User Response

- option 2:** The job step is ended. Any data created up to this point is saved, and the job can continue with the next step.
- option 3:** The job is canceled. Data created by previous steps in this job are saved, but data created in this step are lost.

ODF-9763 Unexpected error in ODF/36 [RSCS link name] [message number] [insert data]

Explanation

An unexpected error has occurred. The link named in the message has terminated. The error message causing this condition is listed in the message as well as the insert data associated with that message.

Do one of the following:

- Try the operation again.
- Give the programmer this message ID (ODF-9763) and the data returned with the message.

Additional Information

If this error continues to occur, fill out a Problem Summary Form found in the *System Problem Determination* manual and call for software service.

User Response

- option 2:** The job step is ended. Any data created up to this point is saved, and the job can continue with the next step.
- option 3:** The job is canceled. Data created by previous steps in this job are saved, but data created in this step are lost.

ODF-9764 RSCS link [link name] has terminated.

Explanation

RSCS link has terminated because of an abnormal termination or a STOPRSCS or ODFCANCL request. If an abnormal termination, check messages previously listed for cause of abnormal termination.

This message is informational only.

ODF-9765 ODF/36 folder, #ODFFLDR, does not exist...

Explanation

The procedure cannot run because the ODF/36 folder does not exist.

Enter option 2 or 3. Run the ODFINSTL procedure to create the ODF/36 folder. See "ODFINSTL Procedure" on page 3-40 for more information on how to create the ODF/36 folder.

User Response

- option 2:** The job step is ended. Any data created up to this point is saved, and the job can continue with the next step.
- option 3:** The job is canceled. Data created by previous steps in this job are saved, but data created in this step are lost.

ODF-9766 ODF/36 folder, #ODFFLDR, is in use...

Explanation

The procedure cannot run because the ODF/36 folder is in use.

Enter option 2 or 3. Run the ODFCANCL procedure to stop all ODF/36 background tasks, before trying the operation again.

User Response

- option 2:** The job step is ended. Any data created up to this point is saved, and the job can continue with the next step.
- option 3:** The job is canceled. Data created by previous steps in this job are saved, but data created in this step are lost.

ODF-9767 [user ID] is not a system console operator...

Explanation

This procedure requires at least system operator authority to run

Enter option 2 or 3.

If you need to run this procedure, contact your security officer to change your classification.

User Response

option 2: The job step is ended. Any data created up to this point is saved, and the job can continue with the next step.

option 3: The job is canceled. Data created by previous steps in this job are saved, but data created in this step are lost.

ODF-9780 Folder exists; press Enter to accept or Cmd7 to end

Explanation

The ODF/36 folder has already been created or another folder with the same name exists on the system.

Do one of the following:

- Continue to the next display by pressing Enter.
- Quit by pressing Cmd7.
- Re-create the folder:
 - Quit the function by pressing Cmd7.
 - Delete or rename the folder using either the DELETE or RENAME procedures.
 - Re-create the folder by running the ODFINSTL procedure.

ODF-9781 File exists; press Enter to accept or Cmd7 to end

Explanation

The ODF/36 file has already been created or another file with the same name exists on the system.

Do one of the following:

- Continue to the next display by pressing Enter.
- Quit by pressing Cmd7.
- Re-create the file:
 - Quit the function by pressing Cmd7.
 - Delete or rename the file using either the DELETE or RENAME procedures.
 - Re-create the file by running the ODFINSTL procedure.

ODF-9782 Folder created; press Enter to continue or Cmd7 to end

Explanation

The ODF/36 folder has successfully been created.

Do one of the following:

- Continue to the the next display by pressing Enter.
- Quit by pressing Cmd7.

ODF-9783 File created; press Enter to continue or Cmd7 to end

Explanation

The ODF/36 file has successfully been created

Do one of the following:

- Continue to the the next display by pressing Enter.
- Quit by pressing Cmd7.

ODF-9784 Defaults set; press Enter to continue or Cmd7 to end

Explanation

The defaults for the ODF/36 PRPQ have successfully been set.

Do one of the following:

- Continue to the the next display by pressing Enter.

- Quit by pressing Cmd7.

ODF-9785 Invalid parameter 1 in SENDPRT procedure

Explanation

SENDPRT was run to send a spooled print file. However, the ENTRIES parameter is invalid.

The allowed values are:

- ALL
All spool file entries for this user will be sent.
- Fxxxx
The forms number of the spool file entries to be sent. xxxx is the 4-character forms number of the entries to be sent.
- SYSTEM
All spool file entries not being processed by spool will be sent.
- SPOOL ID
Six character spool file ID of the spool file entry to send.

If present, select option 2 or 3. If this is part of a job step, give the programmer the message ID. Otherwise, enter the procedure again with the a valid ENTRY parameter.

User Response

option 2: The job step is ended. Any data created up to this point is saved, and the job can continue with the next step.

option 3: The job is canceled. Data created by previous steps in this job are saved, but data created in this step are lost.

ODF-9792 Arrival procedure [procedure name]/[library name] not found for [user ID]

Explanation

The arrival procedure and library named in the message were not found when the user named in the message received an arrived object. The procedure could not be run. This message is an informational message that is only written to the history file.

- Use the ODFPROF procedure to check if the arrival procedure and library named in the message was entered correctly for the user named in the message.

ODF-9800 Object Distribution Facility has been installed

Explanation

The Object Distribution Facility/36 PRPQ has successfully been installed on the system.

Appendix D. Personal Services/36 (SNADS) Messages

This appendix lists and describes messages that appear when an error condition in Personal Services/36 (SNADS) occurs. This appendix is intended to help the system administrator at your site understand the reasons that these messages appear and how to respond to them.

Messages can appear:

- At a display station. Users should report these messages to the system administrator. These messages are recorded in the system history file.
- At the system console. Users do not normally see these messages. These messages are recorded in the system history file. To respond to messages, see *Operating Your Computer*.
- In the history file only. User do not normally see these messages.

Help text is not available online for these system administrator messages. When an error message occurs, use the message identification code (MIC) number to find the message in this appendix.

1000 Cannot access directory file

Cause: The system is unable to open or allocate the directory file. This could happen if this file does not exist, another function has the file locked for exclusive update, or some other file error occurred.

System Administrator Action: If the directory file does not exist, use option 3 (Set up PS/36 (SNADS) support files and folders) on the ODFMNT menu to create it. If an authorized program has exclusive access to this file, retry the operation again when the program is complete.

Retry the operation by sending an object. If this error still exists, ensure that no unauthorized programs access this file and, if this error persists, please call your software representative.

Recovery Options: None

1001 No default address in PS/36 profile record

Cause: The address in the profile record of the directory file is blank. This is an invalid value for the required field.

System Administrator Action: On the ODFMNT menu, choose option 4 (Maintain system defaults for PS/36 (SNADS)) to add the address in the profile record in the directory file.

Recovery Options: None

1008 No PS/36 defaults record in directory file

Cause: The Personal Services/36 (SNADS) defaults record is not in the directory file.

System Administrator Action: On the ODFMNT menu, choose option 4 (Maintain system defaults for PS/36 (SNADS)) to add this record to the directory file.

Retry the operation by sending an object.

Recovery Options: None

1014 Unable to send distribution

Cause: Personal Services/36 (SNADS) is unable to send a distribution because of either a document or system problem.

System Administrator Action: The history file contains entries before this entry that describe the particulars surrounding this error. Follow the action outlined for the specific error.

Recovery Options: None

1019 ##### is an incorrect command code at this time

Cause: A command has been received by the system at a time when the command is invalid. Console message 8701 has been issued in conjunction with this message, indicating the system with which Personal Services/36 (SNADS) encountered the error.

System Administrator Action: Try the attempted operation again. If this error persists, please call your software representative.

Recovery Options: None

1021 #####

Cause: This message area is used to dump exception data and is issued in conjunction with other messages that require assistance from the software representative.

System Administrator Action: Make this message available to the software representative in conjunction with the other messages logged.

Recovery Options: None

1032 I/O error while processing mail queue file

Cause: The system encountered an error while trying to get or put data in the mail queue file.

System Administrator Action: Reorganize the mail queue file using the copydata procedure and retry the operation by sending an object. After using the copydata procedure, remember to delete the original file \$OUMLQ and rename the reorganized file to \$OUMLQ. See the *System Reference* manual for details on the copydata procedure. If this error persists, please call your software representative.

Recovery Options: None

1035 Status deleted without processing

Cause: The status distribution is not complete. It was deleted without having been processed. This deletion may have been caused by a program aborting while writing the mail queue file.

System Administrator Action: No action. If this error persists, please call your software representative.

Recovery Options: None

1039 IU-#####.##### ##### Detected by #####.#####

Cause: A system error was encountered in the distribution named causing it to be canceled. This message is logged in conjunction with other messages that give information on the nature of the error encountered.

System Administrator Action: Try the attempted operation again. If this error persists, please follow the recommended action for the error encountered.

Recovery Options: None

1040 Failed to remove entry from mail queue file

Cause: An entry in the mail queue file could not be removed.

System Administrator Action: Reorganize the mail queue file by using the copydata procedure. After using the copydata procedure, delete the original file \$OUMLQ and rename the reorganized file to \$OUMLQ. Retry the operation by sending an object.

If the error persists, delete the mail queue file and recreate it. Create the file using option 3 (Set up PS/36 (SNADS) support files and folders) on the ODFMNT menu.

If this error still persists, please call your software representative.

Recovery Options: None

1041 #####_##### Protocol error #####

Cause: The protocol error specified has been encountered by the specified user.

System Administrator Action: This message accompanies message 8701 and provides the additional information of signed-on user node and ID. The messages are correlated by the protocol error code specified. Follow instructions specified for 8701.

Recovery Options: None

1051 Cannot access PS/36 resources

Cause: Personal Services/36 (SNADS) files or records could not be accessed. This problem may be caused if the directory file, mail queue file, or mail information file does not exist or is locked for exclusive update; the absence of any of those files; no Personal Services/36 (SNADS) default record; a faulty Personal Services/36 (SNADS) default record; or an I/O error encountered when either file is accessed.

System Administrator Action: Ensure that no unauthorized exclusive use is being made of the directory file, mail queue file, or mail information file. If authorized exclusive use is being made of these files, for example, by the \$OUREORG procedure, wait until the files are available. Then restart the operation by sending an object.

Ensure that the directory file, mail queue file, and mail information file exist on the system and that they are not defined in the Network Resource Directory (NRD).

Note: You cannot use remote files in Personal Services/36 (SNADS).

If they do not exist on the system, use the OFCINSTL procedure to set them up. Ensure that the Personal Services/36 (SNADS) defaults record of the directory file is present. If it does not exist, add it by using option 4 (Maintain system defaults for PS/36 (SANDS)) on the ODFMNT menu. If any of these files are defined in the Network Resource Directory (NRD), remove the definition and create a local copy using the OFCINSTL procedure. This will allow you to use Personal Services/36 (SNADS).

If no error has yet been discovered, attempt to reorganize the directory file and mail queue file using the copydata procedure. After using the copydata procedure, delete the original files \$OUDRFL, \$OUMLQ, and \$OUMLTAB, and rename the reorganized files to \$OUDRFL, \$OUMLQ, and \$OUMLTAB. Restart the operation by sending an object.

If this error persists, please call your software representative.

Recovery Options: None

1052 Directory I/O error in record #####_#####

Cause: The system was unable to read or write the specified record in the directory.

System Administrator Action: Ensure that the specified record exists in the directory file. Note that users having a blank address are part of the default address specified in the defaults record.

If no error has yet been found, condense the directory file. Retry the operation by sending an object.

If this error persists, please call your software representative.

Recovery Options: None

1180 Scheduler information not available

Cause: Some information that should have been built during IPL is missing or has been lost or damaged.

System Administrator Action: Retry the operation. If the operation still does not work, enter the OFCCANCL procedure command and shut down Personal Services/36 (SNADS) background tasks and then IPL again.

Recovery Options: None

1182 PS/36 tasks no longer being stopped

Cause: This message is logged to a user with an outstanding OFCCANCL request when another operation overrides the OFCCANCL request. This request is overridden when a send manager queue is manually started (through OFCQ COMM menu interface or the OFCCTRL procedure interface) or when Personal Services/36 (SNADS) tasks are resumed (OFCCTRL RESUME).

System Administrator Action: This message is for you information only. If you want to stop the Personal Services/36 tasks, you must request OFCCANCL again.

Recovery Options: None

1185 PS/36 tasks stopped

Cause: The Personal Services/36 (SNADS) background tasks have been successfully stopped. The tasks will start again when the next object is sent.

System Administrator Action: This message is for your information only.

Recovery Options: None

1186 PS/36 tasks being stopped

Cause: You have successfully started to stop the Personal Services/36 (SNADS) tasks that do not end on their own. You must do this before maintenance or system shutdown can be performed. The Personal Services/36 (SNADS) tasks will then stop in an orderly way. Any object already in the queue will be delivered locally, or placed in the appropriate remote queue. To stop the tasks as quickly as possible, ask users not to send objects or receive objects. Ask the system administrators of all of the remote systems not to send objects to your system. If objects continue to be sent or objects requiring acknowledgment continue to be received, the Personal Services/36 (SNADS) tasks will not stop. If you want all of the Personal Services/36 (SNADS) background jobs to stop, you should also hold all the send queues.

System Administrator Action: This message is for your information only.

Recovery Options: None

1187 PS/36 tasks being stopped by #####

Cause: Someone else is already stopping the Personal Services/36 (SNADS) tasks. A message confirming that the jobs are stopped is sent to the other person.

System Administrator Action: This message is for your information only; continue using Personal Services/36 (SNADS).

Recovery Options: None

1188 PS/36 tasks not installed

Cause: This message is logged when a distribution arrives for a local user and Personal Services/36 (SNADS) is not installed.

System Administrator Action: Investigate whether or not there is a need to install Personal Services/36 (SNADS). This message may be followed by other messages in the history file which identify the distribution and distribution recipient that caused this message to occur. Undeliverable status will be returned to the distribution sender.

Recovery Options: None

1189 Distribution processing required

Cause: This message is logged when unprocessed distributions are encountered when the system is being IPLed (Initial Program Load).

System Administrator Action: The system administrator should issue the command "OFCCTRL RESUME" to resume distribution processing. This should not be done until after distribution task files are reorganized (system performance may degrade if &OUMLQ is not condensed after every IPL)

Recovery Options: None

1197 Program ##### not supported on local system

Cause: This message is logged when a distribution arrives for a local user but the required receiving program is not available. The data inserted in the message is the destination transaction program name of the function required.

System Administrator Action: Investigate whether or not the feature listed is available for the System/36 and if there is a need for this feature. If both are true, install the feature. This message may be followed by other messages in the history file which identify the distribution and distribution recipient which caused this message to occur. Undeliverable status will be returned to the distribution sender.

Recovery Options: None

1198 PS/36 waiting for #####

Cause: The send manager has tried to acquire a session with a remote system, but the acquisition failed because of a temporary condition. The session group may not be active, a line may not be enabled, or the remote system may not be started up. This message is sent to the console and the history file, along with other messages giving additional information.

System Administrator Action: If the session group is not active or a line is not enabled, use the STRTGRP procedure to activate or enable it. Start the remote system if it is not started. For further information on the cause of this error and the action required, see the additional messages that appeared on the system console and the history file.

Recovery Options: None

1199 PS/36 no longer waiting for #####

Cause: The send manager has successfully retried to acquire a session with a remote system.

System Administrator Action: This message is for your information only; continue using Personal Services/36 (SNADS).

Recovery Options: None

1220 Incorrect input identifier ##### in #####_#####_####

Cause: An unsupported distribution operand was passed while processing a data distribution.

System Administrator Action: Try the attempted operation again. If this error persists, please call your software representative.

Recovery Options: None

1222 Incorrect message ## in #####_#####_####

Cause: The message accompanying a distribution is invalid.

System Administrator Action: Try the attempted operation again. If this error persists, please call your software representative.

Recovery Options: None

1233 #####_#####_####, distribution for list ##### cancel led

Cause: This message informs you that the specified distribution has been canceled because of another error. See accompanying messages in the history file to find out what the particular error was.

System Administrator Action: See action required for accompanying message.

Recovery Options: None

2009 Mail or directory file is in use

Cause: You are trying to make changes to the communications routes or communications queue definitions at the same time a user is trying to send an object.

System Administrator Action: Try again later, or send a message to all users telling them to sign off their systems so you can make your changes.

Recovery Options: 3

2617 Pause-- End of \$OUREORG procedure

Cause: The reorganization procedure is complete.

System Administrator Action: Choose the option 0 to return to the previous display.

Recovery Options: 0

3002 PS/36 defaults not found; see system administrator

Severity: 3

Cause: The merge list function cannot be completed because the directory does not contain a Personal Services/36 (SNADS) defaults record. The default address in the directory Personal Services/36 (SNADS) record is needed when a list is merged.

System Administrator Action: Complete the Personal Services/36 (SNADS) set-up

procedure to recreate the Personal Services/36 (SNADS) defaults record, or replace the directory file \$OUDRFL with one that has a valid Personal Services/36 (SNADS) defaults record.

Recovery Options: 3

3203 No list file access; see system administrator

Severity: 3

Cause: When the user tried to work with lists, the list file \$OUGRFL could not be found, or a security error occurred.

System Administrator Action: Check whether the list file, \$OUGRFL, exists. If it does not exist, restore file \$OUGRFL and the directory file \$OUDRFL to the same date. IPL the system to rebuild the alternative indexed file. If it already exists, and you cannot determine or solve the problem, call your software representative.

Recovery Options: 3

3204 No authority to list file; see system administrator

Severity: 3

Cause: The user tried to work with lists, but does not have the authority to do so.

System Administrator Action: If the user needs to work with lists, enter the Security Editor and add the user to the authorization list.

Recovery Options: 3

3802 Error opening list file; see system administrator

Severity: 3

Cause: When the user tried to view the list file, an error occurred and the list file \$OUGRFL could not be allocated or opened.

System Administrator Action: Check whether the list file \$OUGRFL exists. If it does not exist, restore it. If it already exists, and you cannot determine or solve the problem, call your software representative.

Recovery Options: 3

3804 Error closing list file; see system administrator

Severity: 3

Cause: When the user was viewing the list file, an error occurred, and the list file \$OUGRFL could not be deallocated or closed.

System Administrator Action: If you cannot determine or solve the problem, call your software representative.

Recovery Options: 3

4025 Cannot delete \$OUDRAL; enter 3 to cancel

Severity: 3

Cause:

You are trying to create a file or folder using the Personal Services/36 (SNADS) set-up procedure, and Personal Services/36 (SNADS) has found a mismatch in the number of records in the directory file compared to the number of records in the

alternative indexed file. Personal Services/36 (SNADS) is trying to delete the alternative indexed file, but one of the following conditions may exist:

1. Resource security is active, but you do not have OWNER access to the file \$OUDRAL.
2. Disk I/O error.
3. Another user has exclusive use of the file.
4. The file has been deleted by another user.
5. The file is being used by another user using option 5 on the ODF/36, main menu.

Once you have determined the cause of this error and taken the appropriate action, Personal Services/36 (SNADS) rebuilds the alternative index file based on the directory file when you leave the Personal Services/36 (SNADS) set-up procedure.

System Administrator Action: If the first condition applies, see your security officer to get authority to the file. If the second condition applies, call your software representative. If the third condition applies, see your security officer to get authority to the file. If the fourth condition applies, rerun the Personal Services/36 (SNADS) set-up procedure to create the file \$OUDRAL. If the fifth condition applies, wait until the user is finished working with the directory options. If you still cannot determine or solve the problem, call your software representative.

Recovery Options: 3

4250 Folder not created; VTOC full

Severity: 3

Cause: When performing the setup of files and folders for Personal Services/36 (SNADS), the volume table of contents (VTOC) became full.

System Administrator Action: Clean up your disk and compress it.

Recovery Options: 2,3

4251 Folder not created; no disk space

Severity: 3

Cause: When performing the setup of files and folders for Personal Services/36 (SNADS), there is not enough space on the disk to create the folder.

System Administrator Action: Compress your disk.

Recovery Options: 2,3

4405 Storage folder not created; enter 3 to cancel

Severity: 3

Cause: Any of these conditions may apply:

1. Not enough space on the disk to create the folder.
2. Volume table of contents (VTOC) is full.
3. Disk I/O error.

System Administrator Action: If the first condition applies, compress your disk. If the second condition applies clean up your disk and compress it. If the third condition applies, call your software representative.

Recovery Options: 3

4406 Not authorized to create file/folder; enter 3 to cancel

Severity: 3

Cause: Only a security officer with owner access can create the file or folder.

System Administrator Action: A security officer should go into the Security Editor and give you owner access to this particular file or folder.

Recovery Options: 3

4407 File not created; enter 3 to cancel

Severity: 3

Cause: Any of these conditions may apply:

1. Not enough space on the disk to create the file.
2. Volume Table of Contents (VTOC) is full.
3. Disk I/O error.

System Administrator Action: If the first condition applies, compress your disk. If the second condition applies, clean up your disk and compress it. If the third condition applies, call your software representative.

Recovery Options: 3

4412 PS/36 defaults not created; enter 3 to cancel

Severity: 3

Cause: Any of these conditions may apply:

1. Message load member not found.
2. IBM defaults not found.

System Administrator Action: If the first condition applies, copy the message load member #OU#1MSG from your PID diskettes. If the second condition applies, call your software representative.

4424

5250 Not enough disk space; see system administrator

Severity: 3

Cause: There is not enough disk space to create the files requested. Until disk space is increased, some or all Personal Services/36 (SNADS) functions or procedures may not be available.

System Administrator Action: Refer to the *Procedure and Commands Summary* manual, and run the following procedures:

1. CATALOG
2. SAVE or SAVELIBR
3. DELETE
4. COMPRESS
5. RESTORE.

If a second attempt to create the file fails and if you cannot determine or solve the problem, call your software representative.

Recovery Options: 3

5251 Too many files on system; see system administrator

Severity: 3

Cause: There are too many resident files on the disk. The procedure cannot find space on the volume table of contents (VTOC) to add any new files being created. Some or all of Personal Services/36 (SNADS) procedures or functions are not available until the error is corrected.

System Administrator Action: Try again. If a second attempt to add files fails, use one of the following options to correct the error:

- Delete old files from the volume table of contents (VTOC) to make space for the new files.
- Reconfigure your system using the CNFIGSSP procedure and increase the size of the VTOC.

Recovery Options: 3

5252 ##### does not exist; see system administrator

Severity: 3

Cause: Personal Services/36 (SNADS) cannot find a file with that name. The file was not created, has been renamed, or has been prematurely deleted.

System Administrator Action: Use standard backup procedures to restore the missing file. (Personal Services/36 (SNADS) setup may be required) If the file exists and this message continues to occur, call your software representative. Until the error is corrected, some or all Personal Services/36 (SNADS) procedures or functions are not available.

Recovery Options: 3

5253 ##### already exists

Severity: 3

Cause: Two users have tried to create or name a file with the same label as a system file. This message may indicate an internal programming error. If you are setting up Personal Services/36 (SNADS) files, a file with the same name as the one you are creating is created on the same day but with different attributes.

System Administrator Action: Users cannot create or name files if Personal Services/36 (SNADS) uses that same label. If two users attempt to do so at the same time using the same name, this message appears. Advise users that their file names must be different from Personal Services/36 (SNADS) files and each other's. If this message occurs when the situation just described does not exist, call your software representative. If this message occurs when the Personal Services/36 (SNADS) set up procedure is running, rename or delete this file, and rerun the Personal Services/36 (SNADS) set up procedure again.

Recovery Options: 3

5254 ##### has security problems; see system administrator

Severity: 3

Cause: This message appears when resource security is active and a user has attempted a function or procedure that requires an authorization check on the files being accessed. One of the following conditions may exist:

1. The resource record for that file is secured with the wrong type.
2. The resource record for that file is missing.
3. The alternative indexed file for the resource security on that file contains an error.

System Administrator Action: Determine which of the conditions listed above exists, and perform the corresponding action:

1. A resource can be secured with the wrong type if the SECEDIT RESOURCE procedure was used to secure a file name that matches the name of a folder on the system, or the SECEDIT OFFICE procedure was used to secure a folder name instead of a file. Delete the resource from the incorrect SECEDIT procedure, and secure the resource using the correct procedure.
2. If the resource record for that file is missing, add the missing record or restore the resource security file using the SECREST procedure.
3. If the alternate index for the resource on that file contains an error, update the resource security file using the SECEDIT procedure for the alternate index file named.

Recovery Options: 3

5255 Cannot extend #####; see system administrator

Severity: 3

Cause: Records cannot be added to the specified file. One of the following conditions may exist:

- The file cannot extend. The file contains the maximum number of records allowed.
- There is not enough disk space to extend the file.

System Administrator Action: Refer to the *Procedures and Commands Summary* manual, and run the following procedures:

1. CATALOG
2. SAVE or SAVELIBR
3. DELETE
4. COMPRESS
5. RESTORE

If the file cannot extend, the only option is to delete the old records so new ones can be added.

Recovery Options: 3

5256 Cannot use function now; wait and try later

Severity: 3

Cause: A user attempted to perform a Personal Services/36 (SNADS) function while a disk COMPRESS or SAVE ALL procedure was running. When a COMPRESS procedure is running, files cannot be accessed. When a SAVE ALL procedure is running, files can only be viewed, but not maintained.

System Administrator Action: Personal Services/36 (SNADS) must not be in use by other users when a disk COMPRESS or SAVE ALL procedure is running. Advise users that Personal Services/36 (SNADS) is not available at this time. When the COMPRESS or SAVE ALL procedure is complete, system files can be accessed.

Recovery Options: 3

5257 Must recompress disk; see system administrator

Severity: 3

Cause: The disk COMPRESS procedure was not completed, or an error was found in the COMPRESS procedure. Some or all of Personal Services/36 (SNADS) procedures and functions are not available until the error is corrected.

System Administrator Action: Refer to the *System Reference* manual. To correct this error, you must run the COMPRESS procedure again.

Recovery Options: 3

5258 Index for ##### damaged; see system administrator

Severity: 3

Cause: The index area for this file cannot be used.

System Administrator Action: Perform an IPL and select the FILE REBUILD option. If the error continues to occur, call your software representative.

Recovery Options: 3

5259 Hardware problem; see system administrator

Severity: 3

Cause: An attempt to access a disk has failed. The disk containing the files has a hardware I/O error.

System Administrator Action: Advise Personal Services/36 (SNADS) users that the function is not available at this time. If you cannot determine or solve the problem, call your software representative.

Recovery Options: 3

5260 Problem with this function; see system administrator

Severity: 3

Cause: This message may indicate an internal programming error. The disk I/O request cannot be completed.

System Administrator Action: Call your software representative. Advise Personal Services/36 (SNADS) users that the associated function is not available at this time.

Recovery Options: 3

5261 ##### exists in Network Resource Directory

Severity: 3

Cause: A user attempted to create a file, such as a list file, using the name of a file already contained in the Network Resource Directory (NRD). A file with the same name as one contained in the NRD cannot be created.

System Administrator Action: If you want to use the name entered:

1. Determine if the name is necessary for System/36 operation.
 - If the name is necessary, use the EDITNRD procedure to edit the Network Resource Directory (NRD). Remove the name from the NRD and repeat the create file procedure.

Note:

- a. Only a security officer has access to the EDITNRD procedure.
 - b. You cannot use remote files in Personal Services/36 (SNADS).
- If the name is not necessary, repeat the create file procedure, but this time, enter a different file name.

For all other situations, repeat the create file procedure, but enter a different file name.

For further information on remote files and the Network Resource Directory, see *Distributed Data Management*, SC21-8011.

5262 File ##### is in use, wait and try again

Severity: 1,3

Cause: A user attempted to perform a Personal Services/36 (SNADS) function, while a procedure or a program was running and was using the Personal Services/36 (SNADS) file that the function wanted to use.

System Administrator Action: Check the programs that are running to find out who is using the file. This problem is usually a temporary problem. Retry, using option 1.

Recovery Options: 1,3

5263 File/folder ##### not found, see system administrator

Severity: 3

Cause: This is a hardware problem. A user attempted to perform a Personal Services/36 (SNADS) function, but the file that is required to perform this Personal Services/36 (SNADS) function is located on a disconnected external disk drive. The following are the disk drive numbers:

- 9332 model 220 for 200 MB
- 9332 model 420 for 400 MB.

If after several retries, you cannot use the file, see your system administrator to determine the reason the external disk drive is not connected.

System Administrator Action: The disk drive is not connected for the following reasons:

- The power switch is turned off.
- The plug is not plugged into an AC outlet.

- The cable connection from the disk drive is not connected to the System/36.

After the error is corrected, IPL the system, and retry the function.

Recovery Options: 3

6001 Cannot read directory entry; see system administrator

Severity: 3

Cause: Your directory entry exists, but the system cannot read it. For this reason, the option selected was not performed.

System Administrator Action: Retry the operation. If the situation persists, call your software representative.

Recovery Options: 3

6012 PS/36 defaults unspecified; see system administrator

Severity: 3

Cause: No Personal Services/36 (SNADS) defaults exist on your System/36. Personal Services/36 (SNADS) defaults were not specified at the time of Personal Services/36 (SNADS) setup.

System Administrator Action: Set up Personal Services/36 (SNADS) defaults using option 4 on the ODFMNT menu.

Recovery Options: 3

6013 Address missing from defaults; see system administrator

Severity: 3

Cause: Your System/36 has no address in its Personal Services/36 (SNADS) defaults. You cannot handle objects.

System Administrator Action: Select option 4 (Maintain PS/36 (SNADS) defaults) on the ODFMNT menu and fill in the address.

Recovery Options: 3

7993 ID exists in directory; see system administrator

Severity: 3

Cause: Before or during self-enrollment, another person created a directory entry with the same ID as this user's ID.

System Administrator Action: Give the user another user ID, or change the directory record's user ID.

Recovery Options: 3

8100 Error in processing IU-#####.##### #####

Cause: Personal Services/36 (SNADS) detected an error while attempting to process the incoming item (specified by the sender's address, user ID and the sequence number). Accompanying this message in the history file are more messages (MIC# 8110-8118) giving specifics about how the error occurred (e.g. system error).

System Administrator Action:

1. Your system was receiving a document from another system when this error occurred. Use the remote location name and session list name as indicated in

MIC-8112 to find out the partner system (e.g. System/36 or System/38, etc.) when this error occurred. Ask the system administrator of that system to retry the transmission. If this error persists, please submit an APAR after collecting the required information as indicated below.

2. When you submit an APAR, you must:
 - Indicate the system that was communicating with Personal Services/36 (SNADS) when this protocol error occurred.
 - Indicate the software product Personal Services/36 was communicating with (For example; Personal Services/36 or System/38 Object Distribution)
 - Include a description of the operation involved.
 - Use the History procedure to print off the portion of the system history file containing the error messages issued by Personal Services/36 (SNADS) relating to the error being reported and submit it along with the other APAR material. For more information on the History procedure, see the *System Problem Determination* manual.
 - Submit an APAR according to the APAR procedure. For more information on the APAR procedure see the *System Problem Determination* manual.

Recovery Options: None

8110 IU-#####.##### ##### **Origin:#####** #####

Cause: This message is issued along with message 8100 and 8300. It indicates which data stream encountered an error and what the origin address is. This message is for information purposes only.

System Administrator Action: For further information on the cause of this error and the action required, see the message that appeared on the system console (8100, 8300).

Recovery Options: None

8111 IU-#####.##### ##### **Occurred:##/##/## ##:##:##:##**

Cause: This message is issued along with message 8100 and 8300. It indicates which data stream encountered the error and what date and time the document was sent. This message is for information purposes only.

System Administrator Action: For further information on the cause of this error and the action required, see the message that appeared on the system console (8100, 8300).

Recovery Options: None

8112 IU-#####.##### ##### **Connection:#####.#####**

Cause: This message is issued along with message 8100 and 8300. It indicates which data stream encountered the error and what connection was involved. This message is for information purposes only.

System Administrator Action: For further information on the cause of this error and the action required, see the message that appeared on the system console (8100, 8300).

Recovery Options: None

8113 IU-#####.##### #### Class:#####

Cause: This message is issued along with message 8100 and 8306. It indicates which data stream encountered the error and what the exception class was. This message is for information purposes only.

System Administrator Action: For further information on the cause of this error and the action required, see the message that appeared on the system console (8100, 8306).

Recovery Options: None

8114 IU-#####.##### #### Code:#####

Cause: This message is issued along with message 8100 and 8306. It indicates which data stream encountered the error and what the accompanying condition code was. This message is for information purposes only.

System Administrator Action: For further information on the cause of this error and the action required, see the message that appeared on the system console (8100, 8306).

Recovery Options: None

8115 IU-#####.##### #### Object:#####

Cause: This message is issued along with message 8100 and 8306. It indicates which data stream encountered the error and what the accompanying exception object was. This message is for information purposes only.

System Administrator Action: For further information on the cause of this error and the action required, see the message that appeared on the system console (8100, 8306).

Recovery Options: None

8116 IU-#####.##### #### Data:#####

Cause: This message is issued along with message 8100 and 8306. This indicates which data stream encountered the error and what the accompanying exception data was. This message is for information purposes only.

System Administrator Action: For further information on the cause of this error and the action required, see the message that appeared on the system console (8100, 8306).

Recovery Options: None

8117 IU-#####.##### #### Type:#####

Cause: This message is issued along with message 8100 and 8306 when a SNADS error is detected or along with message 1039 at the system which originated the distribution. The first case indicates which data stream encountered the error and what the accompanying status type was. For the second case, the message specifies SNADS error code returned by the detecting system. This value is in hexadecimal format. In either case, this message is for your information only.

System Administrator Action: For further information on the cause of this error and the action required, see the message that appeared on the system console (8100, 8306).

Recovery Options: None

8118 IU-#####.##### ##### Content:#####

Cause: This message is issued along with messages 8100 and 8306. It indicates which data stream encountered the error and what the accompanying status content was. This message is for information purposes only.

System Administrator Action: For further information on the cause of this error and the action required, see the messages that appeared on the system console (8100, 8306).

Recovery Options: None

8140 Cannot access queue file #####.#####

Cause: The system encountered an error while trying to read data in the mail queue file. This error could happen if this file does not exist, or if there is an error in the index of the mail queue file. This message is issued along with other messages, that provide additional information.

System Administrator Action: If the mail queue file does not exist, use option 3 (Set up Personal Services/36 (SNADS) support files and folders) on the ODFMNT menu to create it. If there is an error on the index, reorganize the mail queue file using the copydata procedure. After using the copydata procedure, remember to delete the original file \$OUMLQ and rename the reorganized file to \$OUMLQ.

Recovery Options: None

8200 Cannot locate queue definition #####.#####

Cause: This message is issued by the scheduler whenever it is unable to update the queue definition (for example, the maximum number of documents allowed in the queue before it is emptied).

System Administrator Action: Check the specified queue definition using the ODFMNT menu. If the queue definition does not exist, then you must create one. Run procedure OFCRBQ regardless of whether or not the queue definition exists. This will re-build the queue definition.

Personal Services/36 (SNADS) builds a copy of the communication queue definition in core (system queue space) to perform scheduling of the send programs in a timely fashion. When this in-core copy of the queue definition is out of sync with the one on the disk, the scheduling function is jeopardized. When such a situation occurs, OFCRBQ has to rebuild the queue definition in core.

Recovery Options: None

8202 Problem with system space

Cause: An attempt to allocate space on the queue has failed. The history file will contain messages before this entry that describe the particulars surrounding this error. Follow the recommended action for the specific error.

System Administrator Action: IPL the system. If the problem continues to occur, contact your software representative.

Recovery Options: None

8300 IU-#####.##### #####: Error in distribution

Cause: The distribution identified in this message was not delivered to some of the intended recipients. Some recipients may have received the distribution. This message is logged at both the system which generates the status and by the system which originated the distribution. To determine why the distribution was not fully delivered, look for accompanying messages in the history file (i.e. 1039, 8110, 8111, 8117, 8302, 8303, 8305).

System Administrator Action: The history file will contain messages before this entry which will describe the particulars surrounding this error. Follow the recommended action for the specific error.

Recovery Options: None

**8302 IU-#####.##### #####: exceeds hop count for
#####.#####**

Cause: The specified data stream has passed through the maximum number of sites allowable and failed to reach its destination.

System Administrator Action: For further information on the cause of this error and the action required, see the messages that appeared on the system console (8300, 8306).

System Administrator Action: Follow the problem determination process described in the *Administering Personal Services/36 in the Office* manual.

Recovery Options: None

8303 IU-#####.##### #####: No route to #####.#####

Cause: Personal Services/36 (SNADS) detected an error while attempting to route the incoming item (specified by the sender's address, user ID, and the message sequence number). This message is issued in conjunction with message 8300.

Recovery Options:

**8304 IU-#####.##### #####: Invalid Addressee
#####.#####**

Cause: The recipient of the specified distribution is not a local user.

System Administrator Action: For further information on the cause of this error and the action required, see the message that appeared on the system console (8300, 8306).

Recovery Options: None

8305 IU-#####.##### #####: for #####.#####

Cause: This message is issued along with message 8300 to identify the intended recipient when the routing error occurred.

System Administrator Action:

Recovery Options: None

8306 #####.##### rejected IU-#####.##### ####

Cause: Personal Services/36 (SNADS) at the receiving system indicated by the remote location name and session group name detected an error while processing the item sent by your system. This message is issued in along with messages 8117, 8302, 8304, or 8305 to further identify the exact cause of the problem.

System Administrator Action: Follow the problem determination process described in the -- Heading id 'PROBS' unknown -- *section of Administering Personal Services/36 in the Office.*

Recovery Options: None

8307 IU-#####_#####_####: **Distribution purged**

Cause: A distribution originating at this system may have been purged while it was waiting on the send queue at a system it passed through to reach the destination. The purge interval is the minimum number of hours that Personal Services/36 (SNADS) lets problem objects sit on the queue before it purges them.

System Administrator Action: This message is sent to the history file and is for your information only.

Recovery Options: None

8308 #####.##### ####: **Function not supported for
#####.#####**

Cause: This message is logged when a distribution is routed to a recipient who is not able to receive the distribution because the function is not supported by their system.

System Administrator Action: This message is is for your information only. You must resend the distribution, making sure not to send an unsupported form.

Recovery Options: None

8500 Folder ##### member ##### not found

Cause: The specified member does not exist on the local system.

System Administrator Action: Try the attempted operation again. If this error persists, call your software representative.

Recovery Options: None

8502 Out of space in folder #####

Cause: New objects could not be added to the specified folder.

System Administrator Action: The specified folder must have its available room increased, either by deleting old objects or by increasing the folder size.

Recovery Options: None

8503 IU-#####.##### #### **remote folder or document library too small**

Cause: The storage folder or the document library at the receiving system indicated by the remote location name and session group name is running out of space while attempting to store this document. This message is issued in along with message 8306.

Recovery Options: None

8701 PS/36 has protocol error ##### with #####.#####

Cause: Personal Services/36 (SNADS) encountered a communication protocol error with the remote system as indicated by the remote location name and the session group name.

System Administrator Action:

1. Inspect the error code in the message. If the error code is prefixed with a D (Dxxxx), then your system was communicating with an IWS; otherwise, (Sxxxx or Rxxxx) your system was communicating with another host system.
2. If your system was communicating with another host, then use the remote location name and session group name as indicated in the message to find out the partner system (for example, System/36 or System/38) when this protocol error occurred. Again, inspect the prefix of the error code. Sxxxx indicates that your system was sending a document when the error occurred, and you should start the transmission again. However, if the error code is prefixed with an R, then your system was receiving a document when the error occurred, and you should ask the system administrator of that system to retry the transmission. If this error persists, please submit an APAR after collecting the required information.
3. When you submit an APAR, you must:
 - Indicate the system that was communicating with Personal Services/36 (SNADS) when this protocol error occurred.
 - Indicate the software product Personal Services/36 (SNADS) was communicating with (For example; Personal Services/36 or System/38 Object Distribution)
 - Include a description of the operation involved.
 - Use the History procedure to print off the portion of the system history file containing the error messages issued by Personal Services/36 (SNADS) relating to the error being reported. For more information on the History procedure, see the *System Problem Determination* manual.
 - Submit an APAR according to the APAR procedure. For more information on the APAR procedure, see the *System Problem Determination* manual.

Recovery Options: None

8823 #####.##### sent NACK with syntax error

Cause: This message is issued by the Send Manager. The specified system has sent an incorrectly formatted negative acknowledgment error message.

System Administrator Action: Try the attempted operation again. If this error persists, please call your software representative.

Recovery Options: None

8825 IU-#####.##### #### partner system: #####.#####

Cause: The specified system sent a negative acknowledgment error message while receiving the specified data stream.

System Administrator Action: Try the attempted operation again. If this error persists, call your software representative.

Recovery Options: None

9003 Procedure \$OUREORG created and placed in #LIBRARY

Severity: 0

Cause: The procedure \$OUREORG (reorganize PS/36 (SNADS) files and folders) is created and placed in #LIBRARY.

System Administrator Action: This is an information message only. It tells you the files and folders to be reorganized are now in \$OUREORG in #LIBRARY. To run the reorganization procedure, type \$OUREORG on the command line and press Enter.

Recovery Options: 0

9006 Procedure \$OUREORG created but cannot be executed

Severity: 0

Cause: The procedure \$OUREORG has been generated and placed into #LIBRARY but cannot be run because the person running the procedure does not have owner access to all the files to be reorganized.

System Administrator Action: Press Enter to continue, and consult the PERSONAL SERVICES/36 REORGANIZE EXCEPTION REPORT to get the names of the files that you do not have owner access to. You can then either get owner access, or delete these file names from the procedure \$OUREORG in #LIBRARY. See *Operating Your Computer* for information on how to delete file names from a procedure.

Recovery Options: 3

9022 Requested function failed; Disk I/O, security edit

Severity: 3

Cause: After creating the directory file, the file could not be opened. Only a security officer with owner access can update the profile record. Resource security may be active, but a security officer still cannot gain access to the file.

System Administrator Action: A security officer should go into the security editor to ensure authority to the file. If the authority is verified, then submit an APAR.

Recovery Options: 3

9023 Procedure cannot run when PS/36 is in use

Severity: 3

Cause: You are trying to save or reorganize Personal Services/36 (SNADS) files and folders, but Personal Services/36 (SNADS) is in use.

System Administrator Action: Make sure no one is using Personal Services/36 (SNADS) when you save or reorganize Personal Services/36 (SNADS) files and folders. You can send a system message to ask users to sign off Personal Services/36 (SNADS).

Recovery Options: 3

9040 For OFCDIR, enter NAME, PHONE, USER, or LIST

Severity: 3

Cause: The user specified an incorrect parameter for the OFCDIR procedure. Use one of the following parameters:

- NAME** To go to the VIEW OR MAINTAIN NAMES AND ADDRESSES display, if you want to see the directory names sorted in alphabetical order, and the first line of each address.
- PHONE** To go to the VIEW OR MAINTAIN TELEPHONE DIRECTORY display, if you want to see the directory's names and telephone numbers listed in alphabetical order.
- USER** To go to the VIEW OR MAINTAIN NAMES SORTED BY USER ID display, if you want to see the user IDs in the directory sorted in alphabetical order.
- LIST** To go to the VIEW OR MAINTAIN NAMES WITHIN A LIST display, if you want to view a personalized directory.

System Administrator Action: Tell the user to try again, and specify the correct parameter.

Recovery Options: 3 H

9041 For OFCMAINT enter ROUTES, QUEUES, MAILFLDR, or REPORT

Severity: 3

Cause: You have entered incorrect parameters for the OFCMAINT procedure. Use one of the following parameters:

- ROUTES** To go to the MAINTAIN COMMUNICATIONS ROUTES display.
- QUEUES** To go to the MAINTAIN COMMUNICATIONS QUEUE DEFINITIONS display.
- MAILFLDR** This parameter is not used by ODF/36.
- REPORT** This parameter is not used by ODF/36.

System Administrator Action: Try again, and specify the correct parameter.

Recovery Options: 3 H

9042 For OFCDATA enter RORG or SAVE

Severity: 3

Cause: You have entered incorrect parameters for the OFCDATA procedure.

System Administrator Action: Type in the correct parameter, and check your spelling before pressing enter. After OFCDATA, type one of the following:

- RORG** To reorganize Personal Services/36 (SNADS) data.
- SAVE** To save Personal Services/36 (SNADS) data.

Recovery Options: 3 H

9049 This is a system operator function

Severity: 3

Cause: This message appears when resource security is active.

A user who does not have system operator authority has attempted to start or stop the activity queue. The unauthorized user sees this message and is prevented from accessing the activity queue.

System Administrator Action: Only a security officer or system operator can start or stop the activity queue. Personal Services/36 (SNADS) users do not have resource authority to perform these procedures. This is an information message.

Recovery Options: 3

9050 This is a security officer function

Severity: 3

Cause: Security is active, and only a security officer can access this function.

System Administrator Action: If you require the use of this function, then you must be at least a security officer.

Recovery Options: 3

9052 You must be at the system console

Severity: 3

Cause: You are trying to use a function that can only be run from the system console. Security is not active.

System Administrator Action: You must go to the system console to use this function. You must be authorized to use the system console. That is, your System/36 profile must indicate that you can access the system console.

Recovery Options: 3

9055 For OFCQ enter COMM or ACTIVITY

Severity: 3

Cause: You have entered incorrect parameters for the OFCQ PROCEDURES.

System Administrator Action: Use one of the following parameters:

COMM To go to the CONTROL COMMUNICATIONS QUEUES display.

ACTIVITY This parameter is no used by ODF/36.

Recovery Options: 0 3

9062 For OFCCOMM enter APPC, QUEUES, RMTDEST or ROUTES

Severity: 3

Cause: You have entered an incorrect parameter for the OFCCOMM procedure.

System Administrator Action: Use any one of the following parameters:

APPC To go to the DEFINE SYSTEM/36 COMMUNICATIONS display.

QUEUES To go to the MAINTAIN COMMUNICATIONS QUEUE DEFINITIONS display.

RMTDEST To go to the MAINTAIN REMOTE DESTINATIONS display.

ROUTES To go to the MAINTAIN COMMUNICATIONS ROUTES display.

Recovery Options: 3 H

9754 Remote location ##### is not active

Cause: For information to flow, the communication subsystem must be enabled and communicating.

System Administrator Action: Enable the communication subsystem. Check the status of communication lines.

Recovery Options: None

9901 Stop requested by operator at the console

Severity: 0

Cause: This message appears at a work station when the operator at the console stops the system. The STOP command begins once a user task has completed.

System Administrator Action: The system will be available when the operator at the console restarts the system.

Recovery Options: 0

9902 Work station display error; try again

Severity: 0

Cause: Information could not be displayed at the work station. A work station hardware or software error may exist, or this may be only a temporary condition.

System Administrator Action: This may be a temporary error. If repeated attempts fail, call your software representative.

Recovery Options: 0

9903 Work station entry error; try again

Severity: 0

Cause: Information could not be entered into the system. A work station hardware or software error may exist or this may be only a temporary condition. Any information entered for this step may be lost.

System Administrator Action: This may be a temporary error. If several attempts fail, and you cannot determine or solve the problem, call your software representative. Advise users their data may be lost and may need to be entered again.

Recovery Options: 0

9907 Work station error; try again

Severity: 3

Cause: Information cannot be entered into the system, and it cannot be displayed on this work station. This message may indicate a temporary condition, or a work station hardware or software error.

System Administrator Action: This may indicate a temporary condition. If several attempts fail, and you cannot determine or solve the problem, call your software representative.

Recovery Options: 3

9908 Cannot display Help; see system administrator

Severity: 0

Cause: The Help program cannot be found in the system library (#LIBRARY).

System Administrator Action: IPL or reload and set up the system. If this message continues to display, and you cannot determine or solve the problem, call your software representative.

Recovery Options: 0

9909 Help cannot be used; see system administrator

Severity: 0

Cause: The Help is not available.

System Administrator Action: If a second attempt fails, call your software representative.

Recovery Options: 0

9948 No authority to mail queue file

Severity: 3

Cause: The user does not have authority to the mail queue file.

System Administrator Action: This message is issued when resource security is active. An unauthorized user has attempted to maintain or control one of the following:

- Communications routes
- Queue entries

Two conditions may cause this message to display. To maintain communications routes or or to control queue entries, the user must:

- Have exclusive access to the mail queue file
- Have update authority to the mail queue file.

Recovery Options: 3

9949 Authority check failed for mail queue file

Severity: 3

Cause: You were attempting to view the mail queue file. Before allowing you to view the mail queue file, Personal Services/36 (SNADS) checks to see if you have the appropriate authority. This authority check failed for one of the following reasons:

- A severe program error occurred.
- A permanent disk error was found.
- The resource security file was not found.
- The history file could not be logged.

System Administrator Action:

1. Do not try this function again.
2. Perform diagnostics to find the source of the error.
 - If this is a permanent disk error, see SYS-8688.
 - If the resource security file was not found, see SYS-8644.

- If the history file could not be logged, see SYS-8665.

3. If you cannot determine or solve the problem, call your software representative.

Recovery Options: 3

9950 Cannot allocate mail queue file

Severity: 3

Cause: Your attempt to display or delete queue entries has failed. Personal Services/36 (SNADS) cannot allocate the mail queue file. If a second attempt fails, one of the following conditions may exist:

1. Another user has exclusive use of the mail queue file.
2. The mail queue file has been prematurely deleted or has not been created.
3. File organization may be damaged.
4. Hardware I/O error may exist.

System Administrator Action: If you cannot determine or solve the problem, call your software representative. Only directory, and list functions are available until the error is corrected.

Recovery Options: 3

9951 Cannot open mail queue file

Severity: 3

Cause: Your attempt to delete queue entries has failed. Personal Services/36 (SNADS) cannot open the mail queue file. One of the following conditions exist:

1. File organization may be damaged.
2. Hardware I/O error may exist.

The mail queue file cannot be accessed until the error is corrected. Only directory, and list functions are available.

System Administrator Action: Determine which of the conditions listed above applies:

1. Check the files to determine if their organization is damaged. Reorganization (IPL) may be required.
2. Check the disks or tapes for damage.

If you cannot determine or solve the problem, call your software representative.

Recovery Options: 3

9952 Cannot allocate mail information or mail queue file

Severity: 3

Cause: Your attempt to display or delete queue entries has failed. Personal Services/36 (SNADS) cannot allocate either the mail queue or mail information file. If a second attempt fails, one of the following conditions may exist:

1. Another user has exclusive use of either the mail queue or mail information file.
2. Either the mail queue or mail information file has been prematurely deleted or has not been created.
3. File organization may be damaged.

4. Hardware I/O error may exist.

Either the mail queue or mail information file and the maintain communications queue definitions function or procedure using the file cannot be accessed until the error is corrected.

System Administrator Action: Determine which of the four conditions listed above applies:

1. Determine if another user has exclusive use of either file. Once the user is no longer using the file, you will have allocate access.
2. Check to see if either the mail queue or mail information file exists. Personal Services/36 (SNADS) set up may be required.
3. Check the files to determine if their organization is damaged. Reorganization (IPL) may be required.
4. Check the disks or tapes for damage.

If you cannot determine or solve the problem, call your software representative. Only directory, and list functions are available until the error is corrected.

Recovery Options: 3

9953 Cannot open mail information or mail queue file

Severity: 3

Cause: Your attempt to delete queue entries has failed. Personal Services/36 (SNADS) cannot open either the mail queue or mail information file. One of the following conditions may exist:

1. File organization may be damaged.
2. Hardware I/O error may exist.

Either the mail queue or mail information file and the maintain communications queue definitions functions or commands using the file cannot be accessed until the error is corrected. Only directory and list functions are available.

System Administrator Action: Determine which of the conditions listed above applies:

1. Check the files to determine if their organization is damaged. Reorganization (IPL) may be required.
2. Check the disks or tapes for damage. If you cannot determine or solve the problem, call your software representative.

Recovery Options: 3

9954 Cannot allocate a mail file or the directory file

Severity: 3

Cause: Your attempt to maintain communication routes has failed. Personal Services/36 (SNADS) cannot allocate either the mail information file, the mail queue, or the directory file. If a second attempt fails, one of the following conditions may exist:

1. Another user has exclusive use to the mail information file or directory file.
2. The mail information file, the mail queue, or the directory file has been prematurely deleted or has not been created.
3. File organization may be damaged.

4. Hardware I/O error may exist.

The mail information file, the mail queue, or the directory file and any functions or commands using those files cannot be accessed until the error is corrected.

System Administrator Action: Determine which of the four conditions listed above applies.

1. Determine if another user has exclusive use to any of these files. Once the user is no longer using the files, you will have allocate access.
2. Check to see if the mail information file, the mail queue, or the directory file exists. Personal Services/36 (SNADS) set up may be required.
3. Check the files to determine if their organization is damaged. Reorganization (IPL) may be required.
4. Check the disks or tapes for damage.

If you cannot determine or solve the problem, call your software representative.

Recovery Options: 3

9955 Cannot open a mail file or the directory file

Severity: 3

Cause: The attempt to maintain communication routes has failed. Personal Services/36 (SNADS) cannot open the mail information file, mail queue, or the directory file. If a second attempt fails, one of the following conditions may exist:

1. File organization may be damaged.
2. Hardware I/O error may exist.

The mail information file or directory file and any functions or commands using those files cannot be accessed until the error is corrected.

System Administrator Action: Determine which of the two conditions listed above applies.

1. Check the files to determine if their organization is damaged. Reorganization (IPL) may be required.
2. Check the disks or tapes for damage.

If you cannot determine or solve the problem, call your software representative.

Recovery Options: 3

9957 Try again; if this fails, mail queue file I/O error

Severity: 3

Cause: The attempt to display or delete queue entries has failed. If a second attempt fails, an error has occurred while the program attempted to read or write a record to the mail queue file. One of the following conditions may exist:

1. File organization may be damaged.
2. Hardware I/O error may exist.

System Administrator Action:

1. Check the files to determine if their organization is damaged. Reorganization (IPL) may be required.
2. Check the disks or tapes for damage.

If the file exists and you cannot determine or solve the problem, call your software representative.

Recovery Options: 3

9960 **Cannot resolve list; see system administrator**

Severity: 3

Cause: There is not enough space to resolve the list. In Personal Services/36 (SNADS), the term resolve means merge.

System Administrator Action: Call your software representative.

Recovery Options: 3

9961 **No PS/36 defaults record in the directory file**

Severity: 3

Cause: Personal Services/36 (SNADS) failed to find a system name in the Personal Services/36 (SNADS) defaults record in the directory file. The directory file is missing the Personal Services/36 (SNADS) defaults record, or the directory file does not exist.

System Administrator Action: Determine if the directory file exists. If it does not exist, set up the directory file again and create the Personal Services/36 (SNADS) defaults.

If you cannot determine or solve the problem, call your software representative.

You cannot maintain or control communications routes or queue definitions until the error is corrected.

Recovery Options: 3

9964 **Cannot access mail files**

Severity: 3

Cause: The attempt to access the mail queue or mail information file has failed.

System Administrator Action: If you cannot determine or solve the problem, call your software representative.

Recovery Options: 3

9978 **Cannot open mail queue or directory file**

Severity: 3

Cause: Your attempt to display queue entries or delete queue entries has failed. Personal Services/36 (SNADS) cannot open either the mail queue or directory file. One of the following conditions may exist:

1. File organization may be damaged.
2. Hardware I/O error may exist.

Either the mail queue or directory file and any functions or commands using the file cannot be accessed until the error is corrected. Only directory, and list functions are available.

System Administrator Action: Determine which of the conditions listed above applies:

1. Check the files to determine if their organization is damaged. Reorganization (IPL) may be required.
2. Check the disks or tapes for damage.

If you cannot determine or solve the problem, call your software representative.

Recovery Options: 3

9979 Cannot allocate mail queue or directory file

Severity: 3

Cause: Your attempt to display or delete queue entries has failed. Personal Services/36 (SNADS) cannot allocate either the mail queue or directory file. If a second attempt fails, one of the following conditions may exist:

1. Another user has exclusive use of either the mail queue or directory file.
2. Either the mail queue or directory file has been prematurely deleted or has not been created.
3. File organization may be damaged.
4. Hardware I/O error may exist.

Either the mail queue or directory file and any functions or procedure using the file cannot be accessed until the error is corrected.

Only directory, and list functions are available until the error is corrected.

System Administrator Action: Determine which of the four conditions above applies.

1. Determine if another user has exclusive use of either file. Once the user is no longer using the file, you will have access.
2. Check to see if either the mail queue or directory file exists. Personal Services/36 (SNADS) setup may be required.
3. Check the files to determine if their organization is damaged. Reorganization (IPL) may be required.
4. Check the disks or tapes for damage.

If you cannot determine or solve the problem, call your software representative.

Recovery Options: 3

9980 No authority to mail queue file

Severity: 3

Cause: This message appears when resource security is active. An unauthorized user has attempted to access the queue entry records in the mail queue file. This message appears to the unauthorized user and prevents access to the mail queue file.

System Administrator Action: Only the owner of the mail queue file can give access authorization. Personal Services/36 (SNADS) users do not have access to the mail queue file.

Recovery Options: 3

9981 Cannot allocate mail information file

Severity: 3

Cause: The attempt to control communications queues has failed. Personal Services/36 (SNADS) cannot allocate the mail information file.

If a second attempt fails, one of the following conditions may exist:

1. Another user has exclusive use of the mail information file.
2. The mail information file has been prematurely deleted or has not been created.
3. File organization may be damaged.
4. Hardware I/O error may exist.

The mail information file and any functions or commands using that file cannot be accessed until the error is corrected.

System Administrator Action: Determine which of the four conditions listed above applies.

1. Determine if another user has exclusive use of the file. Once the user is no longer using the file, allocate access will be available.
2. Check to see if the mail information file exists. Personal Services/36 (SNADS) set up may be required.
3. Check the file to determine if its organization is damaged. Reorganization (IPL) may be required.
4. Check the disks or tapes for damage.

If you cannot determine or solve the problem, call your software representative.

Recovery Options: 3

9982 Cannot open mail information file

Severity: 3

Cause: The attempt to control or maintain communications queues has failed. Personal Services/36 (SNADS) cannot open the mail information file.

If a second attempt fails, one of the following conditions may exist:

1. File organization may be damaged.
2. Hardware I/O error may exist.

The mail information file and any functions or commands using that file cannot be accessed until the error is corrected.

System Administrator Action: Determine which of the four conditions listed above applies.

1. Check the file to determine if its organization is damaged. Reorganization (IPL) may be required.
2. Check the disks or tapes for damage.

If you cannot determine or solve the problem, call your software representative.

Recovery Options: 3

9983 No authority to directory; see system administrator

Severity: 3

Cause:

- The user attempted to use Personal Services/36 (SNADS) directory file, but did not have the authority to do so.

System Administrator Action:

- Give the user read authority or update authority to the directory. Otherwise, tell the user not to attempt to use the Personal Services/36 (SNADS) directory in the future.
- Check to see if the default access to the directory file is READ(R). If it is less than READ(R), change it to READ(R) using the SECEDIT RESOURCE procedure.

Recovery Options: 3

9984 Try again; if this fails, directory file I/O error

Severity: 3

Cause: The attempt to access the Personal Services/36 (SNADS) defaults record in the directory file has failed. Personal Services/36 (SNADS) cannot access the Personal Services/36 (SNADS) defaults record. One of the following conditions may exist:

- Personal Services/36 defaults record may be missing.
- File organization may be damaged.
- Hardware I/O error may exist.

You cannot access the directory file and any functions or procedures using that file until the error is corrected.

System Administrator Action:

- Create the Personal Services/36 (SNADS) defaults record.
- Check the file to determine if its organization is damaged. Reorganization, IPL, or Personal Services/36 (SNADS) 0setup may be required.
- Check the disks or tapes for hardware damage.

If you cannot determine or solve the problem, call your software representative.

Recovery Options: 3

9985 Mail information file is full

Severity: 3

Cause: Another record cannot be added to the mail information file because there is no space left in the file, disk, or tape.

System Administrator Action: To insert more space in the mail information file, clean up and compress the disk. If you cannot determine or solve the problem, call your software representative.

Recovery Options: 3

9986 Cannot generate OCL; #LIBRARY is full

Severity: 3

Cause: Your attempt to save or reorganize Personal Services/36 (SNADS) files and folders has failed. The OCL procedure cannot be saved because there is not enough space in #LIBRARY.

System Administrator Action: Expand #LIBRARY using the allocate library procedure (ALOCLIBR). This procedure is available only if you have a dedicated system.

Recovery Options: 3

9987 For security officer or system operator only

Severity: 3

Cause: The user attempted to perform system administrator functions, but did not have the authority to do so. The user must have security officer or system operator authority.

System Administrator Action: Tell the user not to attempt to perform any administrative functions, or give the user security officer or systems operator authority in a SECEDIT procedure.

Recovery Options: 3

9988 Try again; if this fails, mail information file I/O error

Severity: 3

Cause: The attempt to gain access to communications routes or queues has failed. If a second attempt fails, one of the following conditions may exist:

1. File organization may be damaged.
2. Hardware I/O error may exist.

The mail information file cannot be accessed until the error is corrected.

System Administrator Action: Determine which of the two conditions listed above applies.

1. Check the file to determine if its organization is damaged. Reorganization (IPL) may be required.
2. Check the disks or tapes for damage.

If you cannot determine or solve the problem, call your software representative.

Recovery Options: 3

9989 No authority to mail information file

Severity: 3

Cause: This message is issued when resource security is active. An unauthorized user has attempted to maintain communications routes or queues, or control queue entries. This message is displayed to the user and prevents access to the mail information file.

System Administrator Action: Only the owner of the mail information file can give access authorization to the file. Personal Services/36 (SNADS) users do not have access to the mail information file.

Recovery Options: 3

9991 Authority check failed; see system administrator

Severity: 3

Cause: The user was attempting to view the directory. Before allowing a user to view the directory, System/36 checks to see if this user has the appropriate authority. This authority check failed for one of the following reasons:

- A severe program error occurred.
- A permanent disk error was found.
- The resource security file was not found.
- The history file could not be logged.

System Administrator Action:

1. Tell the user not to try this function again.
2. Perform diagnostics to find the source of the error.
 - If this is a permanent disk error, see SYS-8688.
 - If the resource security file was not found, see SYS-8644.
 - If the history file could not be logged, see SYS-8665.

If you cannot determine or solve the problem, call your software representative.

Recovery Options: 3

9992 I/O error in directory; see system administrator

Severity: 3

Cause: During enrollment, an I/O error occurred when the directory entry was being added.

System Administrator Action: Tell the user to try enrolling again. If the error occurs again, and you cannot determine or solve the problem, call your software representative.

Recovery Options: 3

9994 Authority check failed for mail information file

Severity: 3

Cause: This message is issued when resource security is active. The attempt to maintain communications routes or queues, or access the mail information file has failed. The resource security program has failed in its attempt to verify user authorization to the function or command requiring mail information file access.

System Administrator Action: Advise users that certain functions are not available. You cannot access the mail information file until the problem is corrected.

IPL the system, and test the function again. If this error occurs again, and you cannot determine or solve the problem, call your software representative.

Recovery Options: 3

9996 No PS/36 defaults record; see system administrator

Severity: 3

Cause: The user was attempting to create or update directory entries. The user was unable to do so because the Personal Services/36 (SNADS) default record could not be found in the directory file, or the directory file does not exist.

System Administrator Action: Determine if the directory file exists. If not, perform Personal Services/36 (SNADS) setup to create the directory file and the Personal Services/36 (SNADS) defaults record. If you cannot determine or solve the problem, call your software representative.

Recovery Options: 3

9997 Cannot close directory file; see system administrator

Severity: 3

Cause: The user was working with the directory. The directory file could not be successfully closed or deallocated.

System Administrator Action: Have the user try the same procedure again. If this fails, and you cannot determine or solve the problem, call your software representative.

Recovery Options: 3

9998 Cannot open directory file; see system administrator

Severity: 3

Cause: The user was attempting to work with the directory. The directory file could not be successfully opened.

System Administrator Action: Have the user try the same procedure again. If this fails, and you cannot determine or solve the problem, call your software representative.

Recovery Options: 3

Glossary

A

abnormal termination. A system failure or operator action that causes a job to end unsuccessfully.

access level. The level of authority an operator has in order to use a secured file, library, folder, or folder member.

access method. The way that records in files are referred to by the system. The reference can be consecutive (records are referred to one after another in the order in which they appear in the file), or it can be random (the individual records can be referred to in any order).

acquire. To assign a display station or session to a program.

acquired session. A session that has been started by a System/36 program using an acquire operation, or in BASIC, using an OPEN statement.

adapter. See *communications adapter*.

address. The address, along with the User ID, will identify a user uniquely and is used to direct distributions to the system where this user is located.

addressee. A name, which identifies an individual, that ODF/36 users use when distributing objects.

advanced peer-to-peer networking (APPN). A communications feature that routes data in a network between two or more APPC systems that are not directly attached.

advanced program-to-program communications (APPC). Communications support that allows System/36 to communicate with other systems having the same support. APPC is the way that System/36 puts the IBM SNA LU-6.2 protocol into effect.

allocate. To assign a resource, such as a disk file or a diskette file, to perform a specific task.

alphabetic character. Any one of the letters A through Z (uppercase and lowercase). Some program products extend the alphabet to include the special characters #, \$, and @.

alphameric. Consisting of letters, numbers, and often other symbols, such as punctuation marks and mathematical symbols.

alphanumeric. See *alphameric*.

alternative index. An index that is built after a physical file is created and that provides a different order for reading or writing records in the file. Contrast with *primary index*.

APPC. See *advanced program-to-program communications (APPC)*.

APPN. See *Advanced Peer-to-Peer Networking (APPN)*.

application. (1) A particular business task, such as inventory control or accounts receivable. (2) A group of related programs that apply to a particular business area, such as the Inventory Control or the Accounts Receivable application.

arrived object. An object that has arrived at a System/36 that has not been received. The object is held in a user's list of arrived objects.

application program. A program used to perform an application or part of an

attribute. A characteristic. For example, an attribute for a displayed field could be blinking.

authority. The right to communicate with or use a resource.

authorization list. A list of user identifications and access levels that is used to secure folders, and folder members.

authorize. To allow a user to communicate or use a resource.

authorized program analysis report (APAR). A request for correction of a defect in a current release of an IBM-supplied program.

B

back up. To copy information, usually onto diskette or tape, for safekeeping.

backup copy. A copy, usually of a file, library member, or folder, that is kept in case the original is unintentionally changed or destroyed.

batch. (1) An accumulation of data to be processed. (2) A group of records or data processing jobs brought together for processing or transmission. (3) Pertaining to activity involving little or no user action. Contrast with *interactive*.

batch printing. A printing method in which a print job or jobs print with little or no operator action.

batch processing. A processing method in which a program or programs process records with little or no operator action. Contrast with *interactive processing*.

binary synchronous communications (BSC). A data communications line protocol that uses a standard set of transmission control characters and control character sequences to send binary-coded data over a communications line. Contrast with *synchronous data link control (SDLC)*.

bit. Either of the binary digits 0 or 1. See also *byte*.

block. (1) A group of records that is recorded or processed as a unit. (2) Ten sectors (2560 bytes) of disk storage. (3) In data communications, a group of records that is recorded, processed, or sent as a unit.

BSC. See *binary synchronous communications*.

BSCCEL (binary synchronous communications equivalence link) support. The system support that provides BSC communications with other BSC computers and devices.

buffer. (1) A temporary storage unit, especially one that accepts information at one rate and delivers it at another rate. (2) An area of storage, temporarily reserved for performing input or output, into which data is read or from which data is written.

byte. The amount of storage required to represent one character; a byte is 8 bits.

C

call. (1) To activate a program or procedure at its entry point. Compare with *load*. (2) In data communications, the action necessary in making a connection between two stations on a switched line.

cancel. To end a task before it is completed.

character. A letter, digit, or other symbol.

character key. A keyboard key that allows the user to enter the character shown on the key. Compare with *command keys* and *function key*.

check. (1) An error condition. (2) To look for a condition.

code. (1) Instructions for the computer. (2) To write instructions for the computer. Same as *program*. (3) A representation of a condition, such as an error code.

column. A character position within a print line or on a display. The positions are numbered from 1, by 1, starting at the leftmost character position and extending to the rightmost position.

column separator. A symbol on each side of a position of a field on a display. This symbol does not occupy a position on the display.

command. A request to the system to perform an operation or a procedure.

command key. A keyboard key that is used to request specific programmed actions. Compare with *character key* and *function key*.

comment. Words or statements in a program, or text on a display, that serve as documentation rather than as instructions, choices, or prompts.

communications. See *data communications*.

communications adapter. A hardware feature that enables a computer or device to become a part of a data communications network.

communications file. A file that describes an advanced program-to-program communications (APPC) subsystem session between a System/36 program and a remote device, another program, or another system.

communications line. The line over which data communications takes place; for example, a telephone line.

communications link. See *data link*.

communication queue. A list that keeps track of items to be sent to users on remote systems.

communications routes. A table of remote location, session group pairs used for sending.

communications subsystem. See *subsystem*.

compile. To translate a program written in a high-level programming language into a machine language program.

compiler. A program that compiles.

compress. (1) To move files, libraries, and folders together on disk to create one continuous area of unused space. (2) To delete a series of duplicate characters in a character string.

condition. An expression in a program or procedure that can be evaluated to a value of either true or false when the program or procedure is running.

configuration. The group of machines, devices, and programs that make up a data processing system.

configuration member. In data communications, a member that defines the attributes of a communications subsystem or line.

configure. (1) To describe (to the system) the devices, optional features, and program products installed on a system. (2) To describe to SSP-ICF both the communications facilities connected to System/36 and the attributes of the subsystem and remote system.

console display. A display that can be requested only at the system console. From a console display, an operator can display, send, and reply to messages and use all control commands.

continuation line. A line of a source statement into which characters are entered when the source statement cannot be contained on the previous line or lines.

controller. Circuitry or a device used to coordinate and control the operation of one or more devices.

conversational monitor system (CMS). An operating system that provides general interactive time sharing, problem solving, and program development capabilities, and operates only under the control of the VM/370 control program.

creation date. The program date at the time a file is created. See also *system date*.

current library. The first library searched for any required members. The current library can be specified during sign-on or while running programs and procedures.

current record. The record that is currently available to the program.

cursor. A movable symbol (such as an underline) on a display, usually used to indicate to the operator where to type the next character.

D

data communications. The transmission of data between computers and/or remote devices (usually over a long distance).

data format. The format used by ODF/36 to send data to any system. The data is sent as record images. Contrast *S36FMT format*.

data link. The equipment and rules (protocols) used for sending and receiving data.

deactivate. To make ineffective. For example, to deactivate security.

default. See *default value*.

default printer. A printer that accepts all the printed output from a display station that is assigned to it.

default value. A value stored in the system that is used when no other value is specified.

delete. To remove. For example, to delete a file.

delimiter. A character or sequence of characters that marks the beginning or end of a unit of data.

Development Support Utility (DSU). A program product that can be used to create, edit, remove, view, or print procedure members and source members.

diagnostic. Pertaining to the detection and isolation of an error.

digit. Any of the numerals from 0 through 9.

direct file. A disk file in which records are referenced by the relative record number. Contrast with *indexed file*.

directory. A file containing such information as a name and address for each user of ODF/36.

directory entry. A user's name, address, and other identifying information. See also *directory file*.

directory file. A file of names, addresses, and other identifying information, used as the source for distribution lists.

disable. In interactive communications, to end a subsystem and free the area of main storage used by that subsystem. Contrast with *enable*.

disk. A storage device made of one or more flat, circular plates with magnetic surfaces on which information can be stored.

disk file. A set of related records on disk that is treated as a unit.

diskette. A thin, flexible magnetic plate that is permanently sealed in a protective cover. It can be used to store information copied from the disk or to exchange information with other computers.

DISOSS. See *Distributed Office Support System*.

Distributed Office Support System. Distributed Office Support System (DISOSS) provides host-based library services (file, search, and retrieve) and document distribution to recipients at remote locations.

display. (1) A visual presentation of information on a display screen. (2) To show information on the display screen.

display format. Data that defines (or describes) a display.

display station. A device that includes a keyboard from which an operator can send information to the system and a display screen on which an operator can see the information sent to or the information received from the system.

distribution list. A list of users to receive an object or a message. This distribution list can be contained in a list.

distribution log file. An ODF/36 file used to store important events in the process of distributing an object such as sending an object, routing an object, receiving an object, or deleting an object.

distribution request. A request to send a document, documents, or messages to an individual or to a distribution list.

dump. (1) To copy the contents of all or part of storage, usually to an output device. (2) Data that has been dumped.

dump file. A file that contains the data areas used by a program that failed.

E

edit. (1) To modify the form or format of data; for example, to insert or remove characters such as for dates or decimal points. (2) To check the accuracy of information that has been entered, and to indicate if an error is found. (3) To make changes to a document by adding, changing, or removing text.

element. The smallest unit of data in a table or array.

embedded blanks. Blanks that are surrounded by any other characters.

emulation. Imitation; for example, the imitation of a computer or device.

enable. In interactive communications, to load and start a subsystem. Contrast with *disable*.

enter. To type in information from a keyboard and press the Enter key in order to send the information to the computer.

error code. See *system reference code*.

evoke. In SSP-ICF and DDM, to start a program or procedure so that it can communicate with your program.

expiration date. The date after which a diskette file is no longer protected from being automatically erased by the system.

F

feature. A programming or hardware option, usually available at an extra cost. For example, Communications is a feature of the System Support Program Product.

field. One or more characters of related information (such as a name or an amount).

file. A set of related records treated as a unit.

file name. The name used by a program to identify a file. See also *label*.

first-level message. A message that is issued immediately when an error condition occurs. See also *second-level message*.

folder. A named area on disk that contains either documents, profiles, ODF/36 information, or data definitions.

folder member. A named collection of records or statements in a folder.

format. (1) A defined arrangement of such things as characters, fields, and lines, usually used for displays, printouts, files, or documents. (2) To arrange such things as characters, fields, and lines.

function key. A keyboard key that requests an action but does not display or print a character. The cursor movement and Help keys are examples of function keys. Compare with *command keys* and *character key*.

H

hard copy. A printed copy. Contrast with *online*.

hardware. The equipment, as opposed to the programming, of a system.

Help key. A function key that, when pressed, displays online information or some part of the system help support.

help text. The part of the system help support that offers additional information about displays and messages.

hex. See *hexadecimal*.

hexadecimal. Pertaining to a system of numbers to the base sixteen; hexadecimal digits range from 0 (zero) through 9 (nine) and A (ten) through F (fifteen).

host system. The primary or controlling computer in a communications network.

Houston automatic spooling program (HASP). A computer program that provides supplementary job management, and task management functions such as control of job flow, ordering tasks, and spooling.

I

ICF. See *Interactive Communications Feature (SSP-ICF)*.

I/O. See *input/output (I/O)*.

ID. Identification.

identifier. A sequence of bits or characters that identifies a program, device, or system to another program, device, or system.

index. (1) A table containing the key value and location of each record in an indexed file. (2) A computer storage position or register, the contents of which identify a particular element in a set of elements.

indexed file. A file in which the key and the position of each record are recorded in a separate portion of the file called the index. Contrast with *direct file*.

indicator. An internal switch that communicates a condition between parts of a program or procedure.

information display. A display to enter information from a keyboard.

initial program load (IPL). The process of loading the system programs and preparing the system to run jobs.

input. Data to be processed.

input/output (I/O). Pertaining to either input or output, or both.

instruction. A statement that specifies an operation to be performed by the computer and the locations in storage of all data involved in that operation.

interactive. Pertaining to activity involving requests and replies as, for example, between an operator and a program or between two programs. Contrast with *batch*.

Interactive Communications Feature (SSP-ICF). A feature of the System Support Program Product that allows a program to interactively communicate with another program or system.

interactive processing. A processing method in which each operator action causes a response from the program or the system. Contrast with *batch processing*.

IPL. See *initial program load (IPL)*.

J

job. (1) A unit of work to be done by a system. (2) One or more related procedures or programs grouped into a procedure.

job queue. A list of jobs waiting to be processed by the system.

job step. A unit of work represented by a single program or a procedure that contains a single program. A job consists of one or more job steps.

K

K-byte. 1024 bytes.

Kanji. The ideographic character set used by the Japanese to represent their native language.

key. To enter information from a keyboard.

L

label. (1) The name in the disk or diskette volume table of contents or on a tape that identifies a file. See also *file name*. (2) The name that identifies a statement.

library. (1) A named area on disk that can contain programs and related information (not files). A library consists of different sections, called library members. (2) The set of publications for a system.

#LIBRARY. The library, provided with the system, that contains the System Support Program Product. See *system library*.

library member. A named collection of records or statements in a library. The types of library members are *load member*, *procedure member*, *source member*, and *subroutine member*.

link. In data communications, the connection between two systems.

list. A set of items (user IDs or miscellaneous items) that are known together by a single name.

load. (1) To move data or programs into storage. (2) To place a diskette into a diskette drive or a magazine into a diskette magazine drive. (3) To insert paper into a printer. (4) To mount a tape or insert a tape cartridge into a tape drive.

load member. A library member that contains information in machine language, a form that the system can use directly. Contrast with *source member*.

load module. A program in a form that can be loaded into main storage and run. The load module is the output of the overlay linkage editor.

local. Pertaining to a device, file, or system that is accessed directly from your system, without the use of a communications line. Contrast with *remote*.

local users. A user who is located on site with the host system. This user does not require a communications link to distribute objects.

location name. In interactive communications, the identifying name associated with a particular system or device.

log. To record; for example, to log all messages on the system printer.

local area network (LAN). The physical connection among devices located on the same premises for information transfer.

location name. In interactive communications, the identifying name associated with a particular system or device.

logical unit (LU). The part of a system or device in an SNA network that allows a user or program to use the communications network.

LU. See *logical unit (LU)*.

M

magazine. A container that holds up to 10 diskettes.

master security officer. A person who is designated to control all of the security tasks that are provided with the System Support Program Product. A master security officer can, for example, deactivate password, badge, or resource security, or add, change, or remove security information about any system operator. Contrast with *security officer*.

member. See *library/folder member*.

menu. A displayed list of items from which an operator can make a selection.

message. (1) Information sent to one or more users or display stations from a program or another user. A message can be either displayed or printed. (2) An indication of the condition of the system sent by the system.

message identification. A field in the display or printout of a message that directs the user to the description of the message in a message guide or a reference manual. This field consists of up to four alphabetic characters, followed by a dash, followed by the message identification code.

message identification code (MIC). A four-digit number that identifies a record in a message member. This number can be part of the message identification.

message member. A library member that defines the text of each message and its associated message identification code.

MIC. See *message identification code (MIC)*.

migrate. To convert files created by one program or utility to files that can be used by another program or utility.

module. (1) One part of a program, which usually performs a specific task (such as disk input/output). (2) See *load module*. (3) See *object module*.

multiple. More than one.

multipoint. In data communications, pertains to a network that allows two or more stations to communicate with a single system on one line.

N

NCP. See *network control program (NCP)*.

name of remote location. The name of the remote location for which the session groups will be started.

network. A collection of data processing products connected by communication lines for information exchange between stations.

network control program (NCP). A program, generated by the user from a library of IBM-supplied modules, that controls the operation of a communications controller.

node. (1) An addressable location in a communications network that provides host processing services. (2) A point where packets are received, stored, and forwarded to another node (or DTE) according to a routing method the network has defined.

nonswitched line. A connection between computers or devices that does not have to be established by dialing. Contrast with *switched line*.

numeric. Pertaining to any of the digits 0 through 9.

O

object. A named unit that consists of a set of characteristics that describe the object and, in some cases, data. An object is anything that exists in and occupies space in storage and on which operations can be performed, such as programs, files, libraries, and folders.

Object Distribution Facility/36 (ODF/36). ODF/36 is a S/36 PRPQ that provides a method of sending objects and messages from one S/36 user to another S/36, S/38, AS/400, or S/370 user or list of users. Users can send files, library members, folders, job streams, spooled print files and messages.

object module. A set of instructions in machine language. The object module is produced by a compiler from a subroutine or source program and can be input to the overlay linkage editor.

OCL. See *operation control language (OCL)*.

ODF/36. See *Object Distribution Facility/36(ODF/36)*.

offline. Neither controlled directly by, nor communicating with, the computer. Contrast with *online*.

online. Being controlled directly by, or directly communicating with, the computer, or both. Contrast with *offline*.

online information. Information, read on the display screen, that explains programs, displays, and messages. For some programs, the online information provides all the information needed to use the program. In this case, the online information is similar to printed manuals and may contain a table of contents, guide information, help text for displays and messages, a glossary, and an index.

operating system. A collection of system programs that controls the overall operation of a computer system.

operation. A defined action, such as adding or comparing, performed on one or more data items.

operation control language (OCL). A language used to identify a job and its processing requirements to the System Support Program Product.

option. An item (usually numbered) in a list that a user selects to perform a task.

output. The result of processing data.

overlay. To write over (and therefore destroy) an existing file.

P

parameter. A value supplied to a procedure or program that either is used as input or controls the actions of the procedure or program.

password. A string of characters that, when entered along with a user ID, allows an operator to sign on to the system.

password security. A System Support Program Product option that helps prevent the unauthorized use of a display station, by checking the password entered by each operator at sign-on.

patch. To change directly the contents of a file or library member.

permanent virtual circuit (PVC). A virtual circuit that has a logical channel permanently assigned to it at each DTE. The usual call establishment protocol is therefore not required.

Personal Services/36. A licensed program that can be used to send and receive mail, schedule appointments on calendars, maintain directories of names and addresses, and work with lists of users or calendars.

Personal Services/36 (SNADS). The SNA distribution services part of Personal Services/36. See also *SNADS*.

point. See *node*.

point-to-point line. A communications line that connects a single remote station to a computer.

position. The location of a character in a series, as in a record, a displayed message, or a computer printout.

primary index. The index that is built when a file is created. Contrast with *alternative index*.

printout. Information from the computer that is produced by a printer.

problem determination. The process of identifying why the system is not working. Often this process identifies programs, equipment, data communications facilities, or user errors as the source of the problem.

procedure. A set of related operation control language statements (and, possibly, utility control statements and procedure control expressions) that cause a specific program or set of programs to be performed.

procedure command. A command that runs a procedure.

procedure member. A library member that contains the statements (such as operation control language statements) necessary to perform a program or set of programs.

professional office systems (PROFS). A licensed program product on the VM system that is used to send and receive mail, schedule appointments on calendars, and maintain distribution lists and nickname files.

profile. Data that describes the significant features of a user, program, device, or remote location.

PROFS. See professional office systems (PROFS)

PS/36. See *Personal Services/36*.

program. (1) A sequence of instructions for a computer. See *source program* and *load module*. (2) To write a sequence of instructions for a computer. Same as *code*.

program product. A licensed program for which a fee is charged.

program temporary fix (PTF). A temporary solution to or bypass of a defect in a current release of a licensed program.

prompt. A displayed request for information or operator action.

protocol. A set of rules governing the communication and transfer of data between two or more devices in a communications system.

PTF. See *program temporary fix (PTF)*.

PTF backup library. A library that contains a copy of the load modules replaced by a PTF. The library is created by the PTF procedure with the APPLY parameter specified. When the REMOVE parameter is specified, the PTFs are removed and the original load modules are replaced.

PTF library. A library that contains the PTFs to be applied by the PTF procedure. The library is created by the PTF procedure with the COPY parameter specified.

punch format. The format used by ODF/36 to send data to certain S/370 applications that require the data in 80-column card image format.

purge. To remove, as in an entry from a queue.

Q

qualified name. A name that has been made unique by the addition of one or more qualifiers.

qualifier. A name used to uniquely identify another name.

queue. A line or list formed by items waiting to be processed.

R

read authority. Authority to look at but not change.

record. A collection of fields that is treated as a unit.

remote. Pertaining to a device, file, or system that is accessed by your system through a communications line. Contrast with *local*.

remote. Pertaining to a device, file, or system that is accessed by your system through a communications line. Contrast with *local*.

remote location. The logical location in a Personal Services/36 (SNADS) communications route where objects are sent to a remote system. The remote location is defined during configuration in the APPC or the APPN subsystem.

remote location name. See remote location.

remote location, session group pair. A session started by an incoming procedure start request from a remote system.

remote spooling communications subsystem (RSCS). A virtual machine subsystem of VM/370 that transfers spool files between VM/370 users, remote stations, and remote and local batch systems via HASP-compatible telecommunication facilities.

remote system. Any other system in the network with which your system can communicate.

remote system name. See system name.

remote user. A user who is located on a site other than the host system. This user requires a communications link to distribute objects.

remotely started session. A session started by an incoming procedure start request from the remote system. Contrast with *acquired session*.

reorganize. To move folder members or file records together at the front of the folder or file extents to reduce as much as possible the number of folder extents.

request unit. In SNA, the record transmitted to the other system. This record can contain a request, data, or both.

resource. Any part of the system required by a job or task, including main storage, input and output devices, the processing unit, and files, libraries, and folders.

resource security. A System Support Program Product option that restricts the use of information in files, libraries, folders, and folder members to specified users.

response unit. In SNA, the record sent to respond to a request. The response can be either positive or negative and can include control information.

restore. Return to an original value or image. For example, to restore a library from diskette.

return code. In data communications, a value generated by the system or subsystem that is returned to a program to indicate the results of an operation issued by that program.

reverse image. A way of displaying characters. The characters themselves are dark, while the background surrounding them is highlighted.

roll. To move the display image vertically to bring into view information that is above or below the boundaries of the display.

RSCS. See remote spooling communication subsystem (RSCS)

RU. See *request unit* and *response unit*.

run. To cause a program, utility, or other machine function to be performed.

S

S36FMT format. The format used by ODF/36 to send data to another S/36 or to the AS/400 System/36 environment. The S/36 attributes of the data are preserved. Contrast *data format*.

scroll. To move the display image vertically to bring into view information that is above or below the boundaries of the display.

SDLC. See *synchronous data link control (SDLC)*.

second-level message. A message that supplies additional information about an error condition when the Help key is pressed for a first-level message. See also *first-level message*.

security. The protection of data, system operations, and devices from accidental or intentional ruin, damage, or exposure. See also *system security*.

security officer. A person assigned to control all of the security authorizations provided with the system. A security officer can, for example, remove password or resource security; or add, change, or remove security information about any system user.

session. (1) The logical connection by which a System/36 program or device can communicate with a program or device at a remote location. (2) The length of time that starts when an operator signs on the system and ends when the operator signs off the system.

SEU. See *Source Entry Utility (SEU)*.

SNA. See *systems network architecture (SNA)*.

SNA distribution services (SNADS). An IBM architecture that define a set rules to receive, route, and send electronic distributions in a network of systems.

SNADS. See *SNA distribution services (SNADS)*.

source. A system, a program within a system, or a device that makes a request to a target. Contrast with *target*.

Source Entry Utility (SEU). The part of the Utilities Program Product used by the operator to enter and update source and procedure members.

source member. A library member that contains information in the form in which it was entered, such as RPG specifications. Contrast with *load member*.

source program. A set of instructions that are written in a programming language and that must be translated to machine language before the program can be run.

special character. A character other than an alphabetic or numeric character. For example; *, +, and % are special characters.

spool file. A disk file that contains output that has been saved for later printing.

spool print files. Output in the spool file waiting to be printed.

SSP. See *System Support Program Product (SSP)*.

SSP-ICF. See *Interactive Communications Feature (SSP-ICF)*.

statement. An instruction in a program or procedure.

station. A computer or device that can send or receive data.

status. A condition. For example, the status of a printer, a job, or a communications line.

su
b

su
ir
m

su
th
sy
p

sv
b
d

sy
m
th

sy
co

sy
p

sy
m
d

sy
at

sy
d
a

sy
as
C

sy
P
d

sy
th
is

sy
a
k
is
ic

sy
o
p

Index

Special Characters

\$NTSNO utility program A-2

\$OUSSFL 2-22

#ODFFLDR 2-7

#ODFLOGF 2-8

A

advanced user

ODF/36 folder design 7-2

ODF/36 folder size 7-2

rules to determine size of ODF/36 folder 7-5

tips 7-1

APAR

definition of G-1

APPC 2-26

definition of G-1

appendixes

glossary of terms G-1

APPN 2-26

definition of G-1

archiving

AS/400 on S/36 5-7

S/36 on S/38 5-3

S/36 on the AS/400 System 5-7

S/36 on VM/370 5-5

S/38 on S/36 5-3

arrived objects procedure 4-8

examples 4-9–4-12

ODFPROF 4-8

parameters passed 4-8

address of the sender 4-8

object name part 1 4-8

object name part 2 4-8

object sequence number 4-8

object type 4-8

user ID of the sender 4-8

procedures provided 4-8

RECVFILE 4-8

RECVFLDR 4-8

RECVLIBR 4-8

RECVPRT 4-8

AS/400 System 5-6

archiving AS/400 objects on System/36 5-7

archiving System/36 objects on the AS/400

System 5-7

AS/400 object naming rules 5-6

general object differences 5-7

major differences to consider 5-6

object naming differences 5-6

savefile 5-7

receive using LISTOBJ 5-7

receive using RECVFILE 5-7

resend using SENDFILE 5-7

AS/400 System/36 Environment 5-7

exchanging objects 5-7

receiving objects 5-8

sending objects 5-7

automated and unattended operations 4-1

printing 4-6

processing job streams 4-3

sending jobs from a central site system 4-4

processing spooled print files 4-6

printing with LISTOBJ 4-6

printing with RECVPRT 4-6

Automatic printing 4-6

B

backup copy

definition of G-1

C

central development 4-13

local edit 4-13

remote compile 4-13

changing communications queues and routes using OFCMAINT procedure 3-52

CMS 5-3

definition of G-3

communications

display station 3-36

sending messages to 3-36

operator 3-36

sending messages to 3-36

personal computers 3-36

sending and receiving messages 3-36

communications queues 2-36–2-46

communications routes 2-27–2-36

configuration

software 2-5

control commands

MSG 3-36

cross-system considerations 5-1

D

data descriptor area (DDA) 7-2

data text area (DTA) 7-2

Development Support Utility (DSU)

definition of G-3

directory 1-4

definition of G-3

displaying using OFCDIR procedure 3-50

directory entries 2-47–2-54

add a directory entry for a remote user 2-52

address 2-52

system name 2-52

directory entries *(continued)*

- add a directory entry for a remote user *(continued)*
 - user ID 2-52
 - address 2-47
 - setting up directory entries 2-47
 - system 2-48

displaying communications queues and routes using

OFCMAINT procedure 3-52

displaying messages 3-36

distribution

- object 3-1

distribution log file manager 6-1

E

EXAMPLES diskette file B-1

F

files

- groups 3-59
 - examples 3-59
 - naming conventions 3-59

folder

- #ODFFLDR 2-7
- definition of G-4
- sending using the \$NTSNO utility program A-4

G

groups

- files 3-59
 - naming conventions 3-59

I

ICF 2-27

- definition of G-5

improving system performance 7-1

initializing Object Distribution Facility/36 2-5

- creating the distribution log file 2-8
- creating the ODF/36 folder 2-7
- defaults

ODF/36 2-10

PS/36 2-24

- Personal Services/36 (SNADS) 2-13

installation

- bridge line driver PRPQ 2-1
- Object Distribution Facility/36 2-3
- software 2-1
- System/36 software 2-2
- VM/RSCS 2-1

interactive communications feature

- definition of G-5

J

job stream

- sending using the \$NTSNO utility program A-5

L

library members

- sending using the \$NTSNO utility program A-6

LISTOBJ procedure 3-12

LISTRSCS Procedure 3-30

lists 1-4

local edit 4-13

logical units (LUs)

- definition of term G-6

M

managing communications in batch 4-20

message file

- putting in messages 3-36
- removing messages 3-36

messages

- displaying those sent to you 3-36
- Object Distribution Facility/36 C-1—C-22
- Personal Services/36 (SNADS) D-1—D-36
- sending using MSG command 3-36

MSG command 3-36

- receiving messages 3-36
- sending messages 3-36

MSGFILE procedure 3-36

N

naming conventions

- files 3-59

network control program (NCP)

- definition of G-6

nodes

- definition of G-6

O

object

- definition of G-7

Object Distribution Facility/36 2-3

- definition of G-7
- initialization 2-5
- installation 2-3
- messages C-1—C-22

object naming differences

- AS/400 5-6
- S/38 5-2
- VM/370 5-3

ODF procedure 3-39

ODF/36 procedures 3-1

- LISTOBJ 3-10, 3-12
- LISTOBJ printing with 4-6
- LISTRSCS 3-10, 3-30
- MSG 3-10

ODF/36 procedures (continued)

ODF 3-2, 3-39
 ODFCANCL 3-10, 3-39
 ODFDFLT 3-10, 3-40
 ODFINSTL 3-10, 3-40
 ODFIPL 3-10, 3-41
 ODFLOAD 3-10, 3-42
 ODFPROF 3-10, 3-43
 ODFSTART 3-10, 3-46
 quick reference 3-10
 RECVFILE 3-10, 3-55, 4-8
 RECVFLDR 3-10, 3-56, 4-8
 RECVLIBR 3-10, 3-57, 4-8
 RECVprt 3-10, 3-58, 4-8
 RECVprt printing with 4-6
 SENDFILE 3-3, 3-10, 3-59, A-3
 SENDFLDR 3-4, 3-10, 3-63, A-4
 SENDJOB 3-4, 3-11, 3-65, A-5
 SENDLIBR 3-5, 3-11, 3-67, A-6
 SENDprt 3-5, 3-11, 3-70, A-7
 STOPRSCS 3-11, 3-73
 STRTRSCS 3-11, 3-74

ODFCANCL procedure 3-39**ODFDFLT procedure 3-40****ODFINSTL procedure 3-40****ODFIPL procedure 3-41****ODFLOAD procedure 3-42****ODFPROF procedure 3-43****ODFSTART procedure 3-46****OFCCANCL procedure 3-46****OFCCOMM procedure 3-47****OFCCTRL procedure 3-48****OFCDFLT procedure 3-49****OFCDIR procedure 3-50****OFCGRP procedure 3-51****OFCINSTL procedure 3-51****OFCMAINT procedure 3-52****OFCQ procedure 3-53****P****performance**

DATA format 7-7
 ODF/36 folder design 7-2
 ODF/36 folder size 7-2
 rules to determine size of ODF/36 folder 7-5
 size of task work area 7-6
 SMF 7-6
 S36FMT (S/36 format) 7-6
 tips 7-1

personal computers

sending and receiving messages 3-36

Personal Services/36

definition of G-7

Personal Services/36 (SNADS) 1-4

\$OUSSFL storage folder 2-22

APPC 2-26

APPN 2-26

Personal Services/36 (SNADS) (continued)

communications queues 2-36–2-46

communications routes 2-27–2-31

defaults 2-24

defining communications routes and

queues 2-26–2-46

definition of G-7

directory file 2-13

files

\$OUDRFL 2-13

\$OUGRFL 2-17

\$OUMLQ 2-20

\$OUMLTAB 2-19

initializing 2-13

introducing 1-4

list file 2-17

lists 1-4

mail file 2-19

mail queue file 2-20

messages D-1–D-36

OFCCANCL stop PS/36 background tasks 3-46

OFCCOMM maintain communications

definitions 3-47

OFCCTRL 3-48

OFCDFLT changing defaults 3-49

OFCDIR displaying the directory 3-50

OFCGRP working with user lists 3-51

OFCINSTL installing SNADS files 3-51

OFCMAINT maintaining communications queues

and routes 3-52

OFCQ starting/stopping communications

queues 3-53

sorting requests 1-6

the directory 1-4

printer passthru 4-17

example 4-17

problem determination 6-1

distribution log file manager 6-1

procedures

ALOCFLDR 7-6

CNFIGICF 2-25

COPYDATA 2-20

LISTOBJ 3-10, 3-12

LISTOBJ printing with 4-6

LISTRSCS 3-10, 3-30

MSG 3-10

MSGFILE 3-36

ODF 3-2, 3-39

ODF/36 quick reference 3-10

ODFCANCL 3-10, 3-39

ODFDFLT 3-10, 3-40

ODFDROP 2-5

ODFINSTL 3-10, 3-40

ODFIPL 2-10, 3-10, 3-41

ODFLOAD 2-3, 3-10, 3-42

ODFPROF 3-10, 3-43

ODFSTART 3-10, 3-46

OFCCANCL 3-10, 3-46

procedures (continued)

OFCCOMM 3-10, 3-47
OFCCTRL 3-10, 3-48
OFCDFLT 3-10, 3-49
OFCDIR 3-10, 3-50
OFCGRP 3-10, 3-51
OFCINSTL 3-10, 3-51
OFCMAINT 3-10, 3-52
OFCQ 3-10, 3-53
RCVNETF 5-3, 5-7, 5-8
RECVFILE 3-10, 3-55, 4-8
RECVFLDR 3-10, 3-56, 4-8
RECVLIBR 3-10, 3-57, 4-8
RECVPRT 3-10, 3-58, 4-8
RECVPRT printing with 4-6
RSTS36F 5-8
RSTS36FLR 5-8
SAVS36F 5-7
SAVS36LIBM 5-7
SENDFILE 3-3, 3-10, 3-59, A-3
SENDFLDR 3-4, 3-10, 3-63, A-4
SENDJOB 3-4, 3-11, 3-65, A-5
SENDLIBR 3-5, 3-11, 3-67, A-6
SENDPRT 3-5, 3-11, 3-70, A-7
SNDNETF 5-3, 5-7
STOPRSCS 3-11, 3-73
STRTRSCS 3-11, 3-74
WRKNETF 5-8

processing job streams 4-3

example 4-3

processing spooled print files 4-6

program temporary fix (PTF) 4-15

definition of G-8
distribution 4-15
members with a PTF applied 4-15
PTF Libraries 4-15

R

remote compile 4-13

remote spooling communications subsystem (RSCS)

definition of G-8

remote system

definition of G-8

removing Object Distribution Facility/36 2-5

RSCS 1-5

communications queues 2-36, 2-41, 2-45
communications routes 2-31-2-36
RSCS parameters 1-10
VM/370 5-3

S

savefile

AS/400 savefile 5-7
receive using LISTOBJ 5-3, 5-7
receive using RECVFILE 5-3, 5-7
resend using SENDFILE 5-3, 5-7
S/38 savefile 5-2

security 2-16

SOUDRAL 2-17
SOUDRFL 2-17

sending jobs from a central site system 4-4

sending objects interactively 3-2

setting up 2-1

software 2-1
VM/RSCS 2-1

SNA

definition of G-10

SNADS 1-3

definition of G-9

source (system)

definition of G-9

source entry utility (SEU)

definition of G-9

spooled print files

sending using the \$NTSNO utility program A-7

SSP

definition of G-10

SSP-ICF

definition of G-5

starting communications queues using OFCQ

procedure 3-53

stopping communications queues using OFCQ

procedure 3-53

System Measurement Facility (SMF) 7-6

System/38 (S/38) 5-2

archiving System/36 objects on System/38 5-3
archiving System/38 objects on System/36 5-3
major differences to consider 5-2
object naming differences 5-2
savefile 5-2
receive using LISTOBJ 5-3
receive using RECVFILE 5-3
resend using SENDFILE 5-3
System/38 CPF object naming rules 5-2

T

target (system)

definition of G-10

terms

how PS/36 (SNADS) terms correspond to APPC and RSCS terms 2-27

U

utility programs

- \$NTSNO A-2
 - send a job stream A-5
- SEND utility control statement A-3
- SENDFILE A-3
- SENDFLDR A-4
- sending a folder A-4
- sending disk files A-3
- sending library members A-6
- sending spooled print files A-7
- SENDJ utility control statement A-5
- SENDJOB A-5
- SENDL utility control statement A-6
- SENDLIBR A-6
- SENDPRT A-7
- SENDER utility control statement A-4
- SENDS utility control statement A-7

V

VM

- definition of G-11

VM/370 5-3

- archiving System/36 objects on VM/370 5-5
- CMS 5-3
- definition of G-11
- major differences to consider 5-3
- object naming differences 5-3
- VM/CMS file naming rules 5-3

VTAM

- definition of G-11

READER'S COMMENT FORM

Please use this form only to identify publication errors or to request changes in publications. Direct any requests for additional publications, technical questions about IBM systems, changes in IBM programming support, and so on, to your IBM representative or to your IBM-approved remarketer. You may use this form to communicate your comments about this publication, its organization, or subject matter, with the understanding that IBM may use or distribute whatever information you supply in any way it believes appropriate without incurring any obligation to you.

- If your comment does not need a reply (for example, pointing out a typing error), check this box and do not include your name and address below. If your comment is applicable, we will include it in the next revision of the manual.
- If you would like a reply, check this box. Be sure to print your name and address below.

Page number(s):

Comment(s):

Please contact your IBM representative or your IBM-approved remarketer to request additional publications.

Name _____

Company or
Organization _____

Address _____

_____ City

_____ State

_____ Zip Code

Phone No. _____

_____ Area Code

No postage necessary if mailed in the U.S.A.

Fold and Tape Please do not staple

Cut Along Line



NO POSTAGE
NECESSARY
IF MAILED IN THE
UNITED STATES



BUSINESS REPLY MAIL

FIRST CLASS / PERMIT NO. 40 / ARMONK, NEW YORK

POSTAGE WILL BE PAID BY ADDRESSEE

International Business Machines Corporation
Information Development
Department 245
Rochester, Minnesota, U.S.A. 55901

Fold and Tape Please do not staple

Cut Along Line





IBM System/36
Using the Object Distribution
Facility PRPQ

International Business Machines Corporation

Order Number
SC21-9800-0

Printed in U.S.A.

SC21-9800-00

